

AIWA[®]

S/M Code No.84-003
DATA OF ISSUE 2/1984

SERVICE MANUAL

STEREO TURNTABLE SYSTEM

MODEL NO.

LX-110



TYPE. H, HB, UB, E, EB, K, KB, G

Follow the instructions carefully, which will allow the user to optimise the products' performance and give many years of service.

1. No scratch and melting shall be made to covered lead-wires of an a.c. primary circuit including mains leads.
2. No illegibility shall be given to the specification plate, the caution labels, the fuse labels and others.
3. When, on pattern sides of circuit boards, additional repair-parts have been made up, the parts shall be firmly glued to circuit boards or other components, unless the parts can be attached firmly.
4. The following matters shall be maintained as they are, when repairing.
 - 1) Soldering of lead-wire ends
* Care should be taken of the space distance in an a.c. primary circuit as well as soldering.
 - 2) Wiring and holding of lead-wires with wire-clips and binders
 - 3) Materials of lead-wires
* e.g.; For UL models, lead-wires to be used shall be approved or accepted by the UL.
 - 4) Location of all kinds of insulators
 - 5) Setting of voltage selector switch
* Set the Voltage Selector Switch to 240V, 220V, or 120V, According to your Local Voltage.
5. After repaired, the insulation resistance or leakage current shall be measured with $500 \pm 5V$ D.C and shall be not less than $1M\Omega$.

Measuring Point

Rating : More than $1M\Omega / 500V$ DC

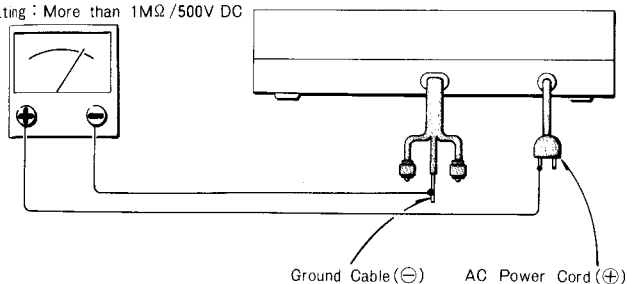

ELECTRICAL MAIN PARTS LIST

“***” shows unavailable Repair Part.

Symbol No.	Part No.	Description	Remark
< MAIN CIRCUIT BOARD SECTION >			
PCB-A	*	Main circuit board	
IC201	84-127-605-01	IC. M58103-400SP	
IC202	87-027-827-01	IC. TC4069UBP	
IC203	87-020-149-01	IC. BA6208	
IC204.205	87-020-148-01	IC. M5224P	
IC206	87-020-147-01	IC. M54547P	
Q201.204.	89-318-464-01	Transistor. 2SC1846(R.S)	
Q202	89-210-670-01	Transistor. 2SB1067	
Q203.205	89-110-155-01	Transistor. 2SA1015(GR)	
Q206	89-318-155-01	Transistor. 2SC1815(GR)	
Q207.211.212	89-320-011-21	Transistor. 2CS2001(K.L)	
Q208.213	89-318-154-01	Transistor. 2SC1815(Y)	
Q214.215.216.217	89-334-000-01	Transistor. 2SC3400	
Q218	87-026-198-01	Transistor. DTA124	
D201.202	87-027-365-01	Diode. S5277B	
D203.205.209.210.219.220.221.222.223.224.225.226.227.228.229.230.231.234.237	87-027-097-01	Diode. 1S1555	
D204	87-027-509-01	Zener diode. HZ12B3	
D206.235.236	87-027-332-01	Zener diode. HZ-6B1L	
D207.208	87-027-942-01	LED. EBR5534S(STROBO)	
D211.212.213.214.215.216.217.218	87-027-943-01	LED. PR5731K(PROGRAM [1][2][3][4][5][6][7][8]. REPEAT)	
D219.220.221.222.223.224.225.226.227.228.229.230.231.234.237	87-027-097-01	Diode. 1S1555	
D232.233	87-027-479-01	Zener diode. HZ-27-2	
L1	84-127-640-01	Choke coil. 100μH	
△SW201	87-031-805-01	Push-switch (POWER)	
SW202.203.204.205.206.207.208.209.210.211.212.213.214.215.216.217	87-031-741-01	Tact switch (PROGRAM [1][2][3][4][5][6][7]. ALL CLEAR. INTRO. REPEAT. ◀. ▶. UP/DOWN. F.SKIP. B.SKIP. START/CUT)	
SW218	87-031-737-01	Push-switch (SPEED)	
SW219	87-031-738-01	Slide switch (SENSOR)	
X201	84-127-606-01	Ceramic resonator. X500K(P)	
SFR201	87-021-746-01	Semi-fixed resistor. 100kΩ-B	
SFR202	87-021-749-01	Semi-fixed resistor. 470kΩ-B	
SFR203	87-021-744-01	Semi-fixed resistor. 33kΩ-B	
PIN201.204.208	87-049-275-01	Pin. 5P	***
PIN202	87-049-357-01	Pin. 5P	***
PIN203	87-049-374-01	Pin. 8P	***
PIN205	87-049-396-01	Pin. 2P	***
PIN206	87-049-273-01	Pin. 3P	***
PIN209	87-049-356-01	Pin. 5P	***
PIN210.211.	87-049-260-01	Pin. 2P	***
CN207	87-047-104-01	Connector ass'y. 6P	***
< Capacitors >			
C213.302	87-018-044-01	1000pF	

Symbol No.	Part No.	Description	Remark
PCB-B	*	ANGLE sensor circuit board	
CPI	87-031-736-01	Photo interrupter. KU107	
CN206	84-127-639-01	Connector ass'y. 3P	***
< PHONO MOTOR CIRCUIT BOARD SECTION >			
PCB-C	—	Phono motor circuit board	
M1. PIN207	84-124-630-01	DC motor(PHONO)	
< POSITION SENSOR CIRCUIT BOARD SECTION >			
PCB-D	*	Position sensor circuit board	
Q401.402	84-124-667-01	Photo transistor. PIN150(C)	
D401	84-195-638-01	LED. LN55(SENSOR)	
CN208	84-127-639-11	Connector ass'y. 5P	***
< DISK SENSOR CIRCUIT BOARD SECTION >			
PCB-E	—	Disk sensor circuit board	
	84-127-019-21	Tone arm ass'y [cartridge ass'y. with PCB-E (DISC SENSOR C.B)]	
< VOLUME CIRCUIT BOARD SECTION >			
PCB-F	*	Volume circuit board	
VR501	82-576-603-01	Volume. 10kΩ-B (SPEED)	
< MISCELLANEOUS >			
△T1	84-127-614-01	Power transformer (H. HB models only)	
△T1	84-127-611-01	Power transformer (UB model only)	
△T1	84-127-612-01	Power transformer (E. EB models only)	
△T1	84-127-613-01	Power transformer (K. KB. G models only)	
M2.3	84-127-601-01	DC motor (UP/DOWN. LINEAR)	
△	84-033-140-01	Splice connector	***
△	87-034-956-01	AC power cord (H model only)	
△	87-034-958-01	AC power cord (HB model only)	
△	87-034-578-01	AC power cord (UB model only)	
△	87-034-877-01	AC power cord (E. EB models only)	
△	87-034-711-01	AC power cord (K. KB. G models only)	
△	87-085-165-01	Cord bushing (H. HB models only)	
△	87-085-184-01	Cord bushing (UB model only)	
△	87-085-185-01	Cord bushing (E. EB. K. KB. G models only)	
SW101.102	87-031-736-01	Leaf switch (DOWN-SENSOR. UP-SENSOR)	
SW301	84-127-603-01	Rotary switch (AC VOLTAGE) (H. HB models only)	
J1	87-049-060-01	Jack. 2.5φ (REMOTE)	
CN203	84-127-636-11	Connector ass'y. 8P	***
CN204	84-127-637-11	Connector ass'y. 5P	***
CN205	84-127-638-01	Connector ass'y. 2P	***
CN211	84-127-635-11	Connector ass'y. 2P	***
	84-199-606-01	Output cord ass'y (L-ch. R-ch OUT-PUT)	
	84-124-605-01	REC SYNC cord Ass'y	

△ Safety component symbol
This symbol is given to important parts which serve to maintain the safety of the product, and which are made to conform to special safety specifications. Therefore, when replacing a component with this symbol, make absolutely sure that you use a designated part.

Note; Combination Circuit Board
The parts on the electrical parts list which are indicated by an asterisk (*) are supplied as one single combined circuit board. Therefore, they will not be supplied separately. If this becomes necessary, please order the entire circuit board.

Combination circuit board A 84-127-620-11
PCB-A 84-127-621-11
PCB-F 84-127-623-11

Combination circuit board B 84-127-626-01
PCB-B 84-127-628-01
PCB-D 84-127-627-01
PCB-D 84-127-629-01

ADJUSTMENT

1. Stylus height adjustment

- 1) Place a service jig on the external circumference of the rubber sheet and turn the adjustment screw to adjust so that the stylus height is at the position shown in the diagram. (Refer to Fig. 1)

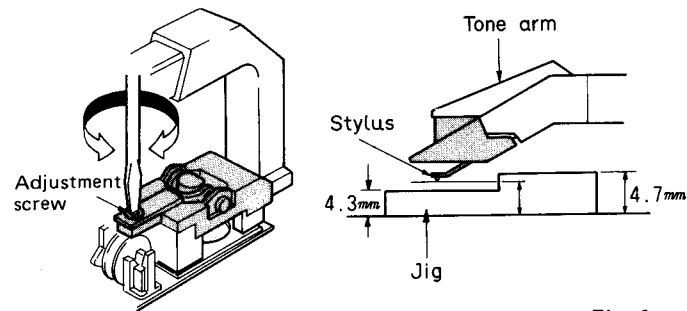

Fig. 1

- 2) Turn the turntable 180° after adjusting the height at adjustment point (1); if the stylus height at adjustment point (2) is 4.7mm or more, adjust it again. (Refer to Fig. 2)

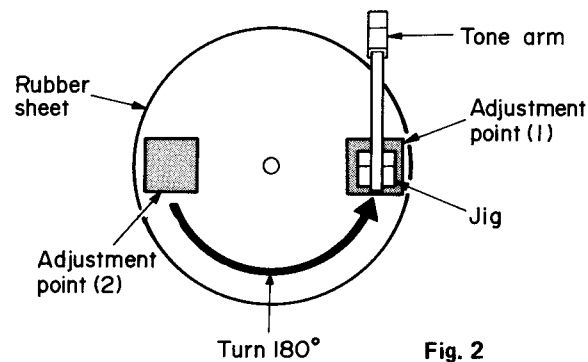

Fig. 2

- Reference
1. Standard: 4.2 ~ 5.2mm.
 2. When the cabinet is attached, the adjustment height may be approx. 0.2mm higher.

2. Angle sensor (A sensor) adjustment

Perform this adjustment after adjusting the stylus height.

- 1) Remove the belt of the linear motor.
- 2) Short-circuit TP 4, 5 and stop the turntable.
- 3) Place a test record (ATR-003) on the turntable.
- 4) Turn the adjustment boss clockwise (in the direction of the arrow) and move the holder fully in the direction of the arrow. (Refer to Fig. 3)
- 5) Move the tone arm to the auto check 25cm position by hand.
- 6) Adjust SFR 203 so that the voltage between test points TP1 and TP3 is $8 \pm 1V$. (UP condition)
- 7) Press the UP/DOWN button to lower the arm.
- 8) Turn the adjustment screw clockwise so that the voltage is 0.4 ~ 0.5V. (DOWN condition)

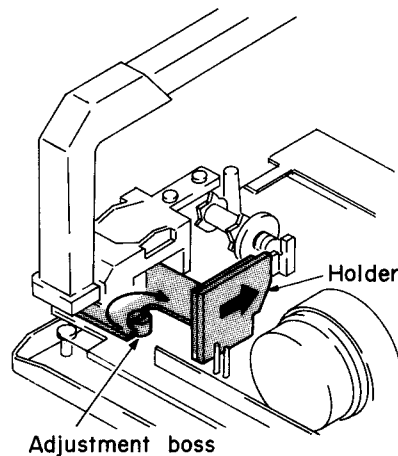

Fig. 3

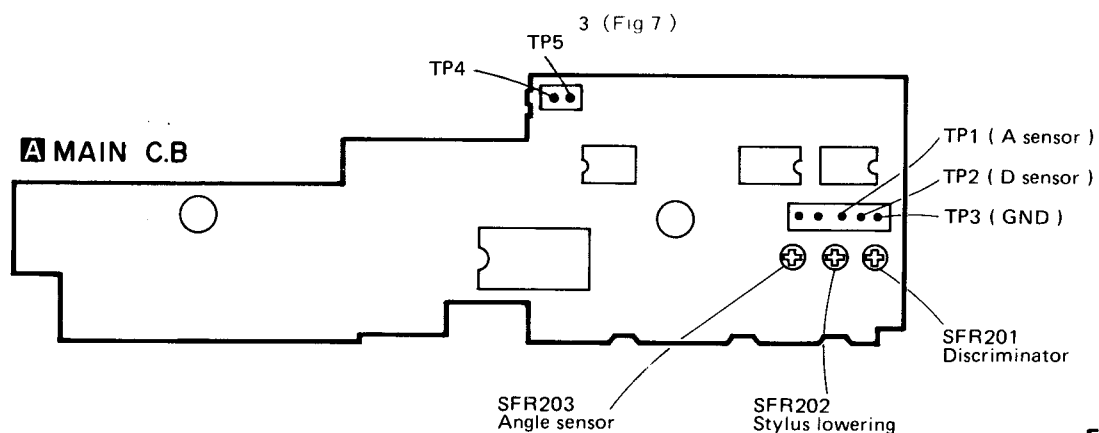

Fig. 4

3. Discriminator sensor (D sensor) control

Perform this adjustment after adjusting the stylus height.

- 1) Set the sensitivity select switch to "NORMAL".
- 2) Short-circuit TA 4 and TP 5 to stop the turntable.
- 3) Apply an arrow mark to the test record.
Procedure: Apply an arrow mark at right angles to the line from the point where the feed groove enters the 7th tune "wow/flutter 3kHz" from the 6th tune "no-sound groove". up to the center hole.

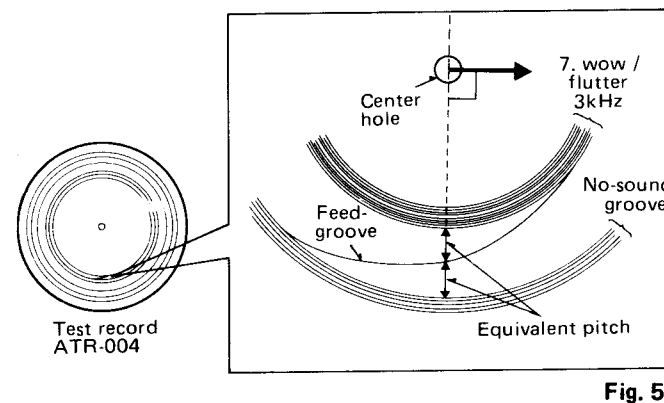

Fig. 5

4. Auto-in/out adjustment

30 cm record

- 1) Place AIWA test record (ATR-003) on the turntable, press the START/CUT button and turn the adjustment boss to adjust so that the auto-in count is 22 ~ 28. (Refer to Fig. 7)
- 2) Check that the auto-out count is 11 ~ 14 after adjustment is completed.
Adjust the auto-in again when the auto-out count is out of the specified range (11 ~ 14).

17 cm record

- 1) Press the START/CUT button and check that the auto-in count is 24 ~ 37.
- 2) Check that the auto-out count is 15 or more after adjustment is completed.
(Method to check)
Prepare paper as shown in the diagram, place it under the stylus and move the tone arm and pull out the paper when the tone arm passes the 25cm lead-in. (Refer to Fig. 8)

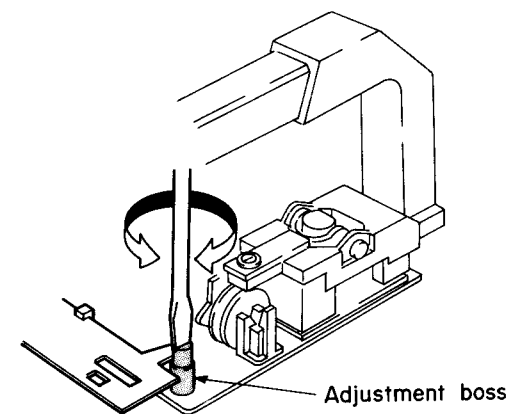

Fig. 7

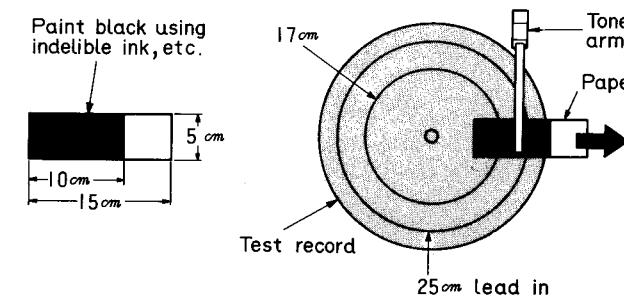

Fig. 8

5. Stylus lowering position adjustment

When SFR 202 is turned clockwise, the stylus moves approx. 0.1 ~ 0.2mm inward, and when it is turned counterclockwise, it moves approx. 0.1 ~ 0.2mm outward. When the stylus height adjustment position is set to 4.3mm, the stylus lowering position moves approx. 0.1mm outward with the height to adjusted 4.7mm. (Refer to Fig. 9)

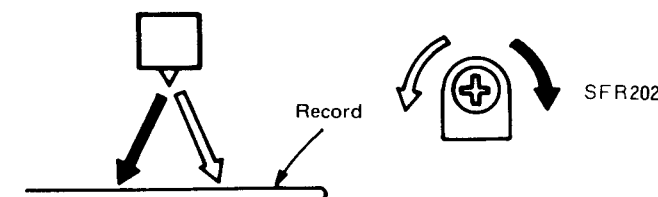

Fig. 9

Sensitivity selector	NORMAL
Rotation speed	33 rpm

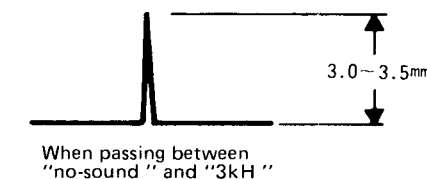

Fig. 6

Return the arm to the arm rest, operate as shown in item 6 again, and check that the height of the waveform is within the specified range.

CIRCUIT DESCRIPTION

PROGRAM TUNE-SELECTION MECHANISM

1. Outline

When the tuner is selected by the program button operation and the START button is pressed, the arm moves to the internal circumference while it is kept in the UP state. The inter-tune position is detected by the disc sensor during this movement and memorized by the microcomputer. The size is sensed simultaneously at this time. The arm moved to the internal circumference moves to the 1st tune of the program and is lowered. When the performance starts (when the arm is lowered), the MS circuit works: when the no-signal state continues for 1.5 sec or more, the circuit makes the arm move UP and the arm moves to the 2nd tune. (It moves to the next tune directly without returning to the arm rest.)

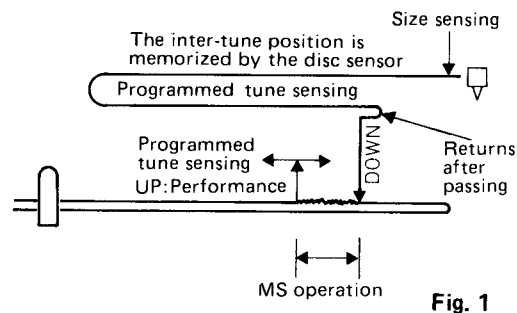

Fig. 1

2. Memorizing inter-tune position

Slits are engraved with a pitch of 1mm on the mark (black metal plate) of the position sensor as well as holes which sense the rest position, 30cm records and 17cm records. The number of slits before the slit where the inter-tune signal is output is sensed by the microcomputer, to sense the inter-tune position. (The microcomputer counts 1, 2, 3, 4... every time the position sensor passes the slit.)

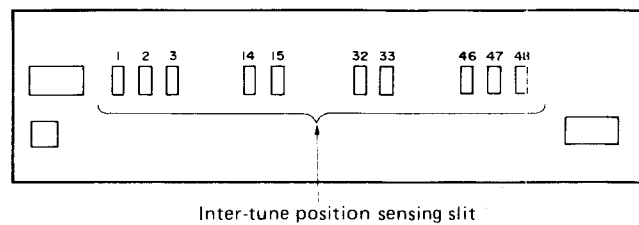

Fig. 2

6) A4 is a comparator with hysteresis, and it compares V4 and Vc, and makes the rise of its output V0 the inter-tune sensing signal. (Refer to Fig. 5)

Fig. 5 a. Inter-tune sensing signal

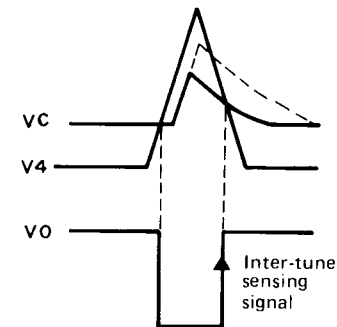

Fig. 5

4. MS circuit

1) When the arm is lowered, muting of Q211, Q212 is released and the signal enters the MS circuit.
2) When the arm comes the ±1 count (Slit No. of the mask sensor) of the inter-tune position which was sensed previously during the arm UP operation, the microcomputer (IC201) starts to monitor the MS signal.
3) When the no-sound state continues for 1.5 sec or more, it is judged as inter-tune and the arm lifts. (However, when the programmed numbers continue, the arm does not lift but the performance is continued as it is.) (MS sensitivity is not related to the positions of SW119 and the sensor switch (LOW, NOR, HIGH).)

3. Disc sensor circuit

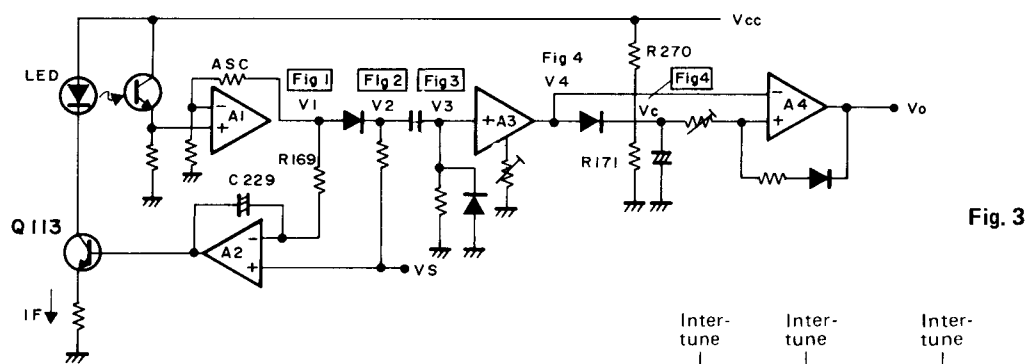

Fig. 3

- 1) Light from the LED is reflected by the record, enters the phototransistor and is converted to current. This signal is amplified by A1 of IC205, and V1 is obtained. This output V1 is compared with the reference voltage Vs, and controlled by the time constant of R169 and C229 so that V1 = Vs. (When the amount of light entering the photo transistor increases, the internal resistance of Q113 is increased to dim the LED so that the amount of light incident on the photo transistor is always kept constant.)
- 2) When the arm passes the inter-tune, the incident amount of light is increased, but the time constant T is smaller than R169 · C229, so the waveform as V1 shown in Fig. 1 is obtained.
- 3) When the waveform is sliced by the dot line (a) via the slice circuit, the waveform shown as V2 in Fig. 2 is obtained.
- 4) By differentiating this, the waveform shown as V3 in Fig. 3 is obtained.
- 5) By amplifying this via A3, the waveform shown as V4 in Fig. 4 is obtained: Vc is obtained by peak-holding this.

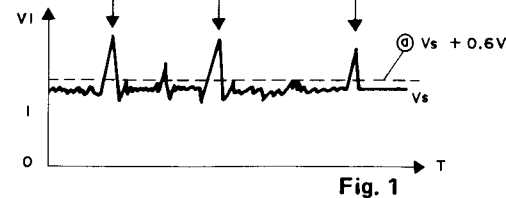

Fig. 1

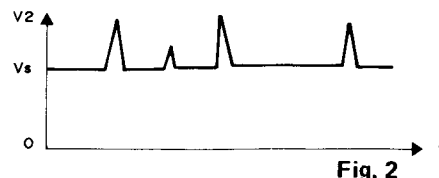

Fig. 2

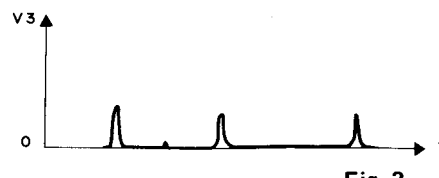

Fig. 3

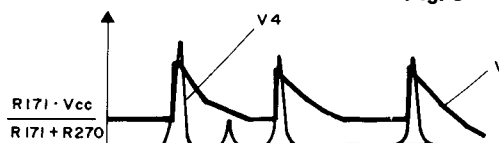

Fig. 4

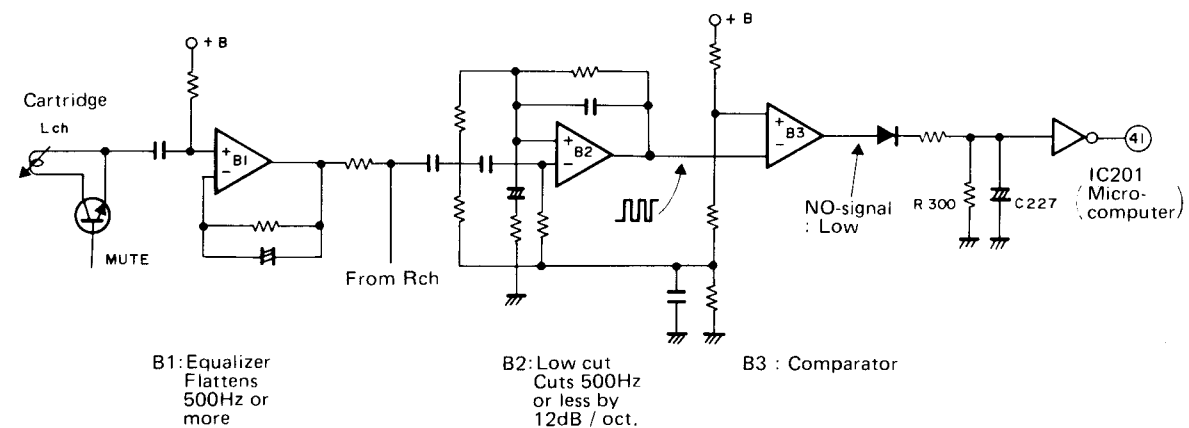
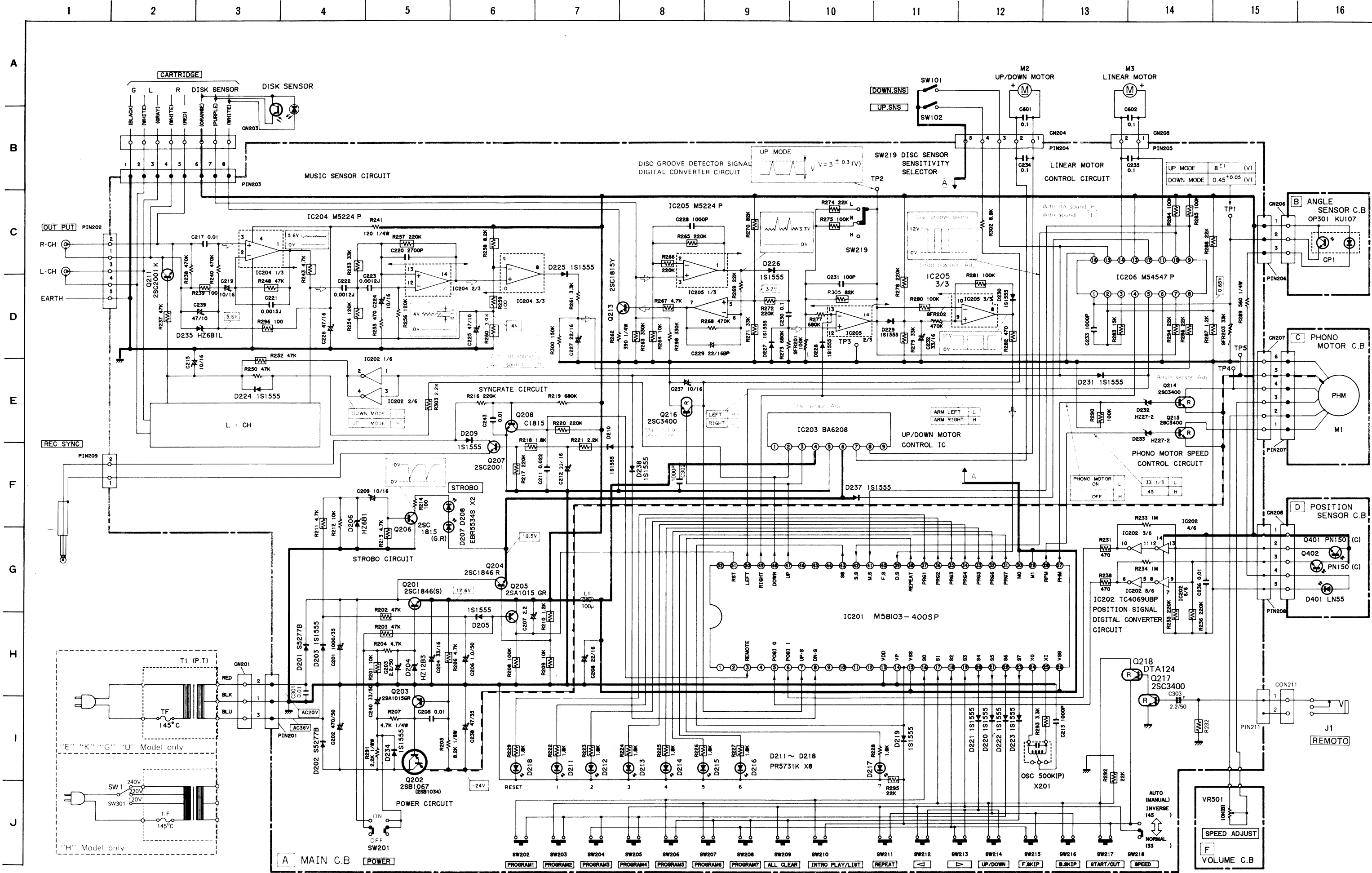
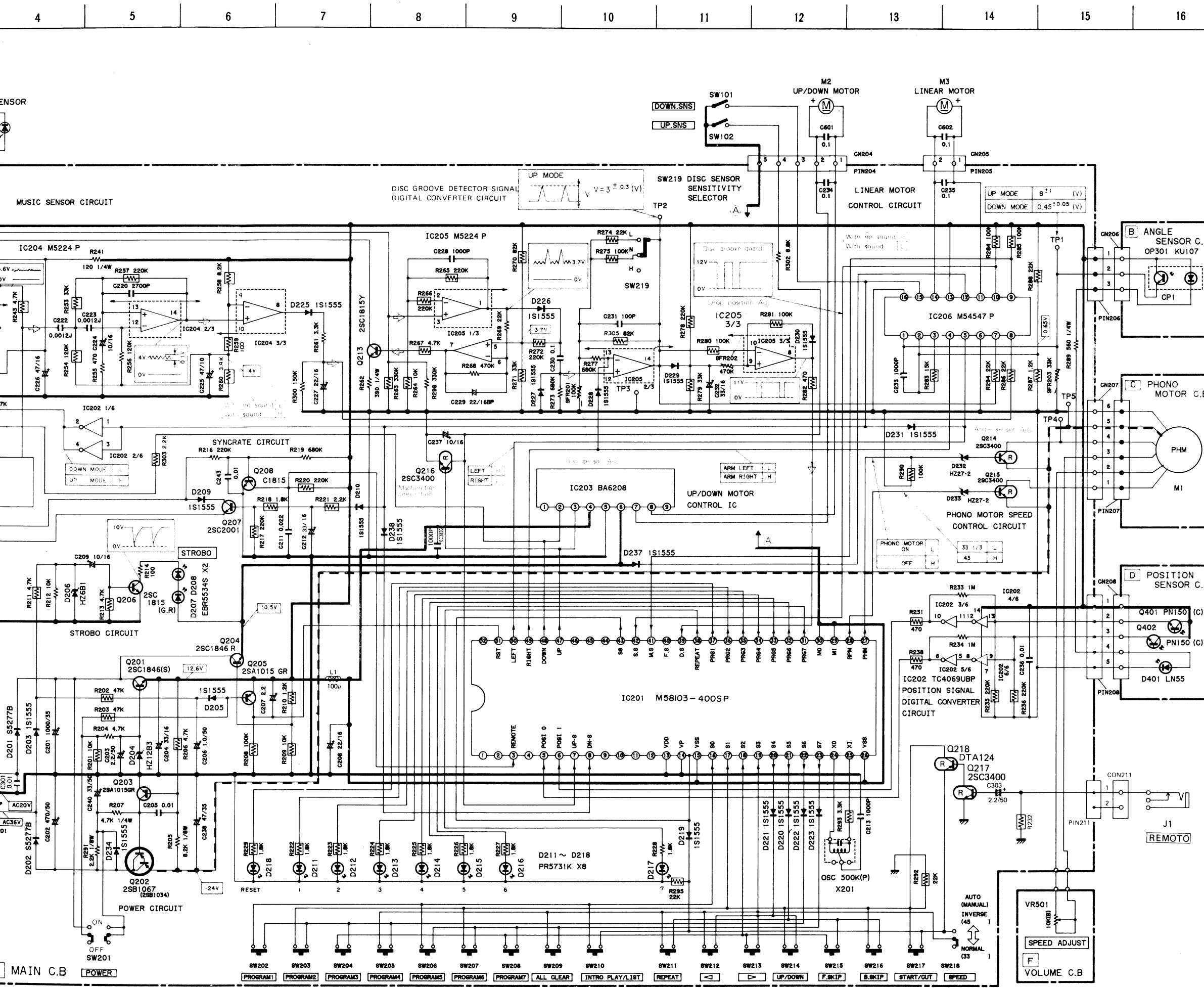

Fig. 6

SCHEMATIC DIAGRAM-1



- A MAIN C.B
- POWER
- PROGRAM1
- PROGRAM2
- PROGRAM3
- PROGRAM4
- PROGRAM5
- PROGRAM6
- PROGRAM7
- ALL CLEAR
- INTRO PLAY/LIST
- REPEAT
- UP/DOWN
- F.SKIP
- B.SKIP
- START/CUT
- SPEED
- VR501
- SPEED ADJUST
- VOLUME C.B
- F



NOTES:

- 1) B (+) power supply B (-) power supply
- 2) Signal path

The voltage is the reference value measured with a tester (20 k-ohms/V DC) when there are no signals. But () is with AM reception or recording. An asterisk (*) indicates that the value was measured with a vacuum-tube voltmeter during recording. Resistors with no designation have a rated power of 1/4W and a tolerance of ±5%. Capacitors with no designation have a dielectric strength of less than 50WV. The only capacitor tolerance indicated are ±5% (J) and ±10% (K). Ceramic capacitor symbols:

- For temperature compensation (SL)
- High dielectric constant system (YY)
- High dielectric constant system (YW, YP, YZ)
- Semiconductor ceramic
- For temperature compensation (SH)

Explanation of symbols

- Mylar capacitor
- Aluminum solid capacitor
- Polypropylene film capacitor
- Printed resistor
- Fuse resistor

Safety component symbol

This symbol is given to important parts which serve to maintain the safety of the product, and which are made to conform to special safety specifications. Therefore, when replacing a component with this symbol, make absolutely sure that you use a designated part. This schematic diagram is subject to change without notice in the interests of improved performance.

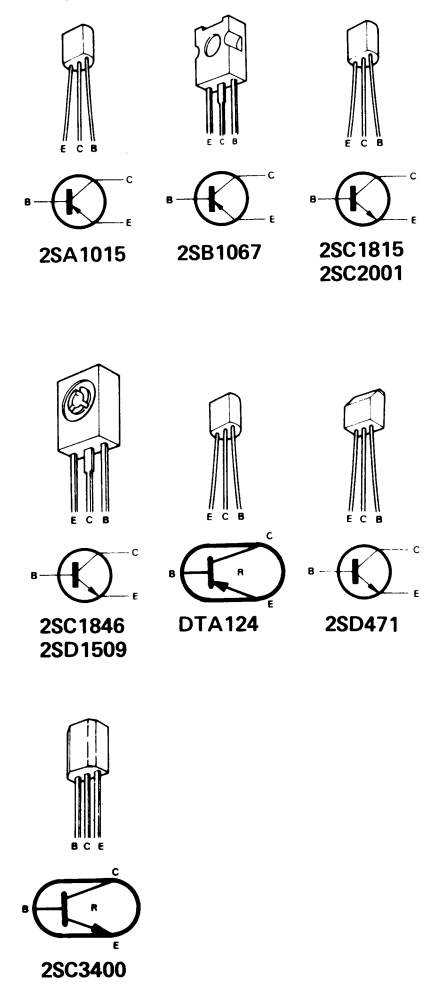

MAIN C.B

IC201 M54103-400SP Pin Specifications		
Pin No.	Pin mark	Function
1, 2	————	Not used.
3	REMOTE	Remote control input. Start performance at the rise to "HIGH" from "LOW".
4	————	Not used.
5	POST 0	Detects the amount of movement of the tone arm by counting the position sensor input pulses.
6	POST 1	Tone arm movement range detection input. The arm can move within a certain range at "L" level.
7	UP-S	Tone arm UP sensor input. "H" during UP operation.
8	DN-S	Tone arm DOWN sensor input. "H" during DOWN operation.
9, 10, 11	————	Not used.
12	VDD	GND
13	V _{DD}	GND
14	V _{SS}	+12V
15	————	Not used.
16~19	S ₀ ~S ₃	Key inputs
20~23	S ₄ ~S ₇	Key matrix outputs
24	X ₀	Clock output. 6V _{p-p} , 500kHz.
25	X ₁	Clock input. 12V _{p-p} , 470kHz.
26	V _{SS}	+12V
27	PHM	Phonomotor ON/OFF control output. Rotates at "L" and stops at "H".
28	RPM	Phonomotor speed control output. "L": 33 rpm "H": 45 rpm
29	M ₁	+12V
30	M ₀	+12V
31 37	PRG 7 PRG 1	Program No. LED indication outputs. Lit at "H".
38	REPEAT	REPEAT indication output. Lit at "H".
39	D. S	Disc sensor input. The rise to "H" from "L" is set to becomes the input.

Pin No.	Pin mark	Function
40	—	Not used.
41	MS	Performance finish signal input.
42	SS	Record size detection input. The rise from "L" to "H" is the input.
43	S _s	Key matrix output.
44~46	—	Not used.
47	UP	Arm UP output. "H" during arm UP operation.
48	DOWN	Arm DOWN output. "H" during arm DOWN operation.
49	RIGHT	Arm rightward movement output. "H" during arm movement to the right.
50	LEFT	Arm leftward movement output. "H" during arm movement to the left.
51	RST	RESET input. Reset when "H" level is applied for the period of 36 μs or more.
52	—	Not used.

IN PUT			OUT PUT		Remarks
IN SW	IN R	IN L	OUT R	OUT L	
0	1	0	1	0	Forward rotation(during arm UP and movement to the right)
0	0	1	0	1	Reverse rotation(during arm UP and movement to the left)
0	1	1	0	0	Brake
1	0	0	1	0	Analog forward rotation(Not possible in normal operation)
1	0	1	0	1	Analog reverse operation(during arm DOWN operation)

Note) • IN_{sw} = 1 } Inhibit
 IN_i = 1 }
 • Oscillation may occur when the brake is applied.

IC BA6208

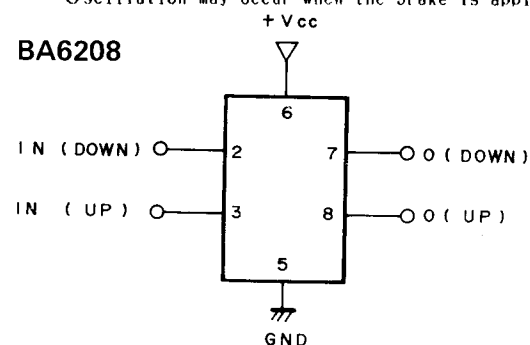

IN (DOWN)	IN (UP)	O (DOWN)	O (UP)	Arm operation
1	0	H	L	DOWN
0	1	L	H	UP
1	1	L	L	None in general
0	0	H	H	Stop

[Arm position and microprocessor port]

	POS1 0	POS1 1
Rest position	1	1
30 TOP	No. 2	0
25 TOP	No. 14	0
17 TOP	No. 33	0
30 END	No. 47	0
17 END	0	1

POSITION SENSOR

[Mask plate hole and operation]

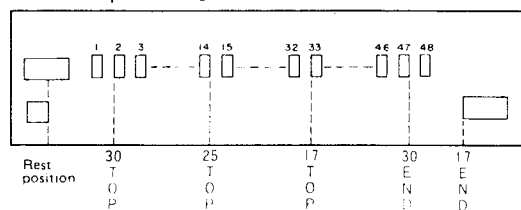
Q402 IC201
POS1 0 (pin 5)Q401 IC201
POS1 1 (pin 6)

IC M54547

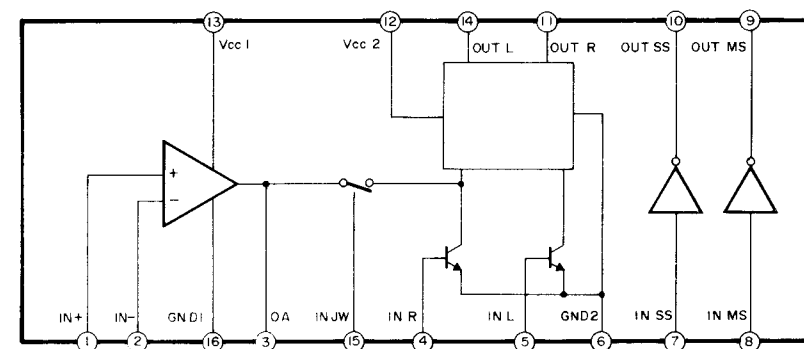

Pin No.	Pin mark	Function
1	IN+	Angle sensor input. Voltage rises when arm angle drifts.
2	IN-	Operation amp (-) pin.
3	OA	Operation amp output.
4	IN R	Rightward movement input.
5	IN L	Leftward movement input.
6	GND ₂	GND
7	IN SS	Size sensor input
8	IN MS	Music sensor input
9	OUT MS	Music sensor output
10	OUT SS	Size sensor input
11	OUT R	Rightward movement output. 8 V during arm UP and movement to the right.
12	Vcc ₂	+10 V
13	Vcc ₁	+12 V
14	OUT L	Leftward movement output. 3~4 V during arm DOWN operation and 8 V during arm UP. movement to the left.
15	IN SW	Set to "H" during arm DOWN operation and the switch inside IC is set to ON.
16	GND ₁	GND

WIRING-1

1 2 3 4 5 6 7 8 9 10 11 12 13 14 15 16

A
B
C
D
E
F
G
H
I
J

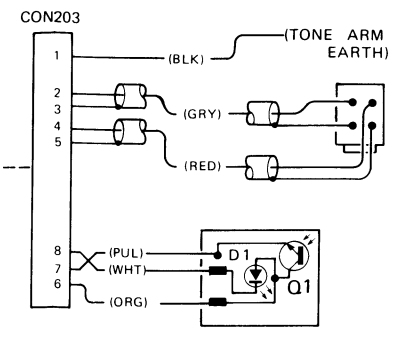
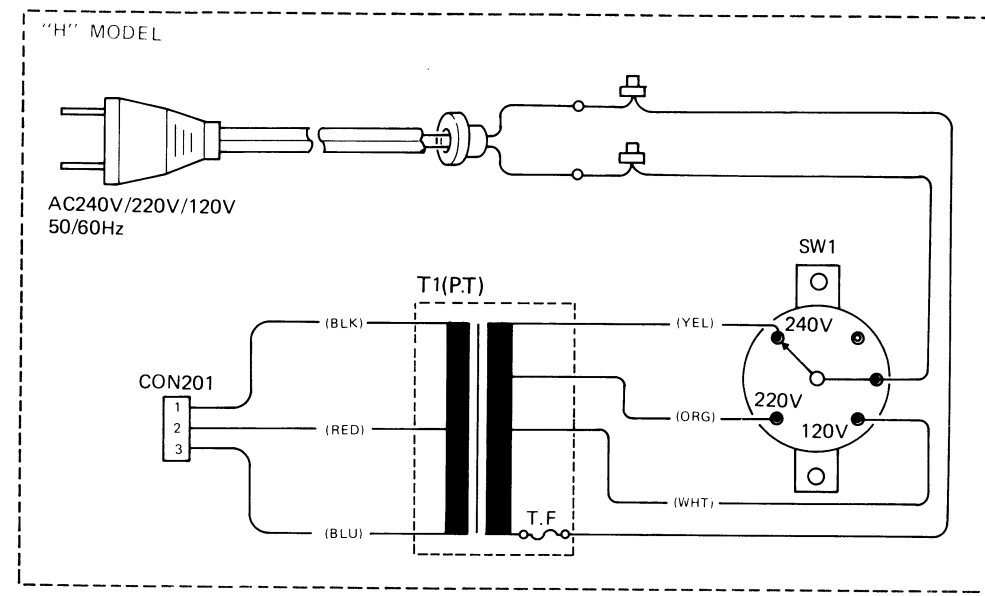
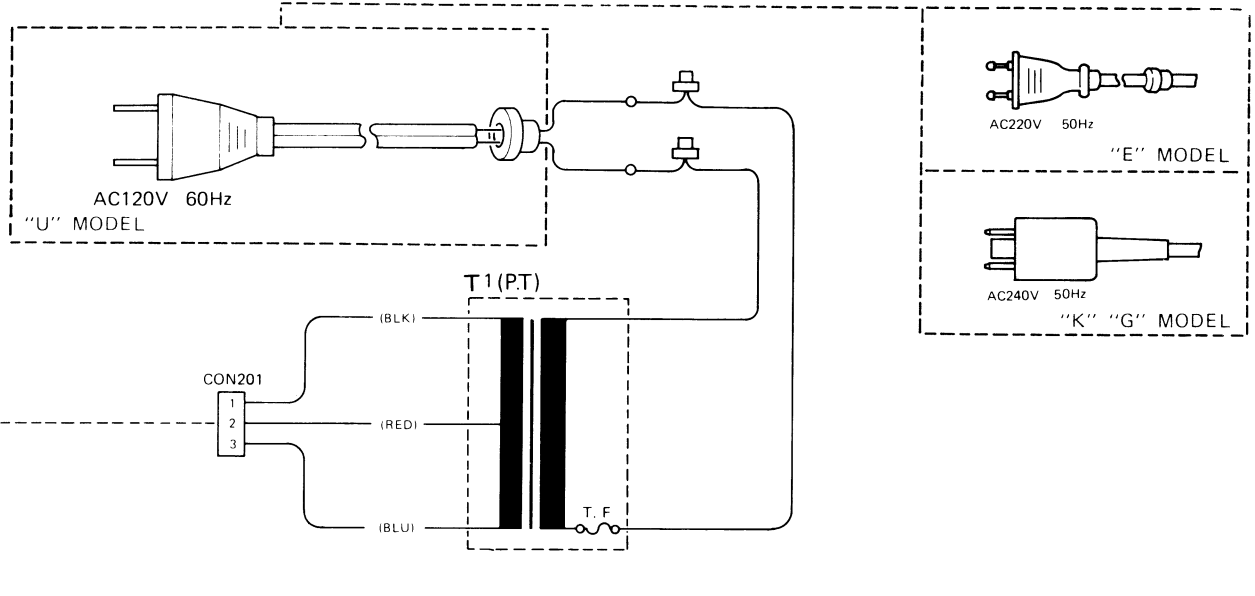

B ANGLE SENSOR

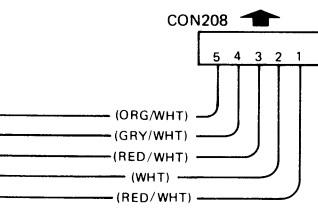
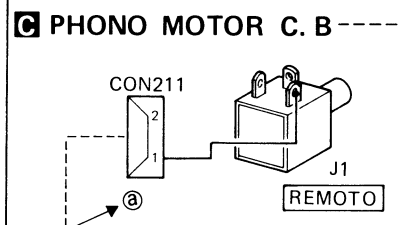
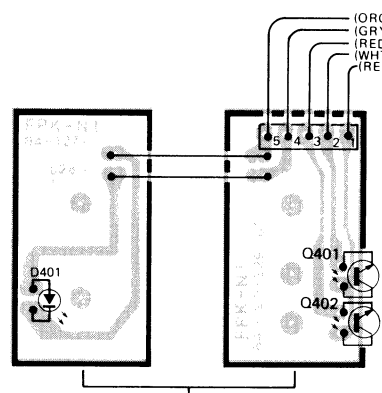
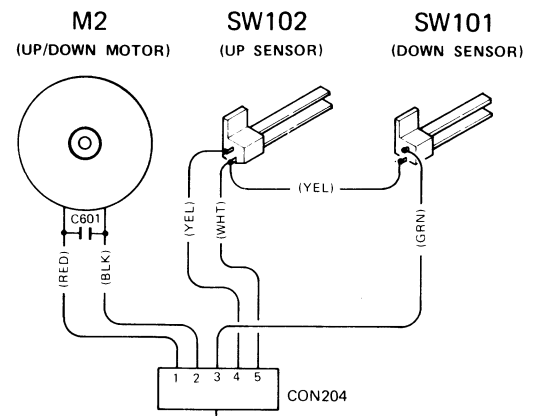
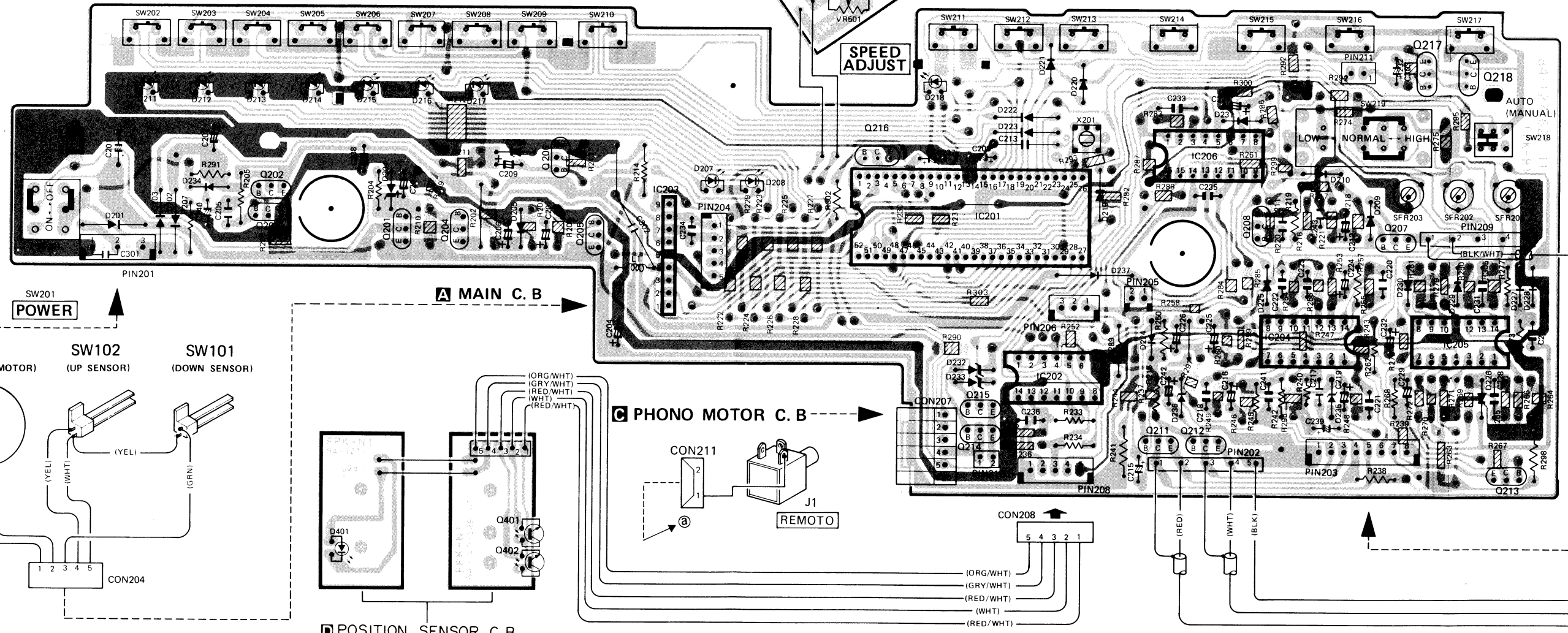
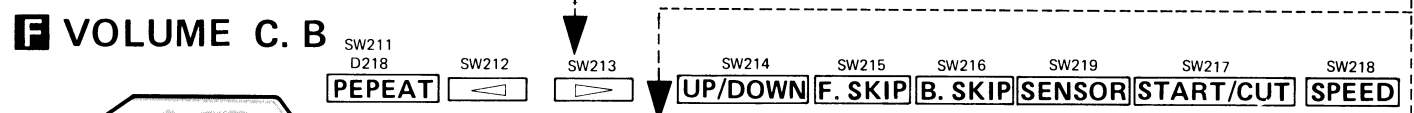
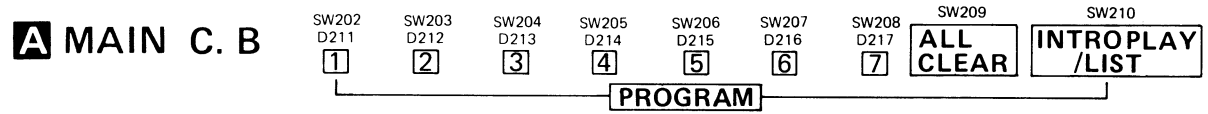

33r.p.m - - 45r.p.m

4 5 6 7 8 9 10 11 12 13 14 15 16 17 18 19

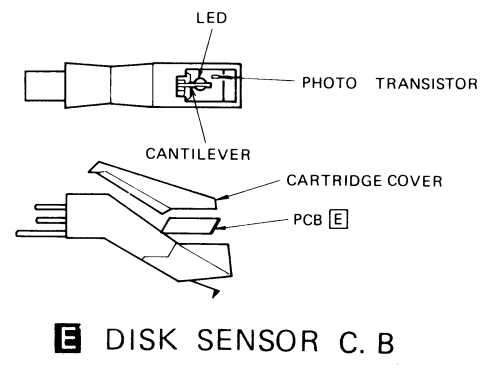
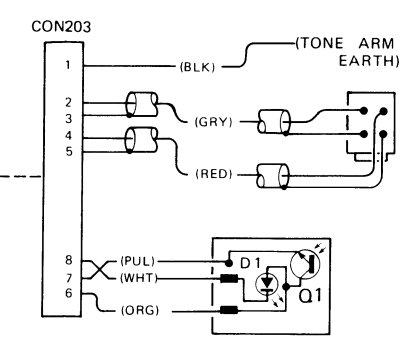
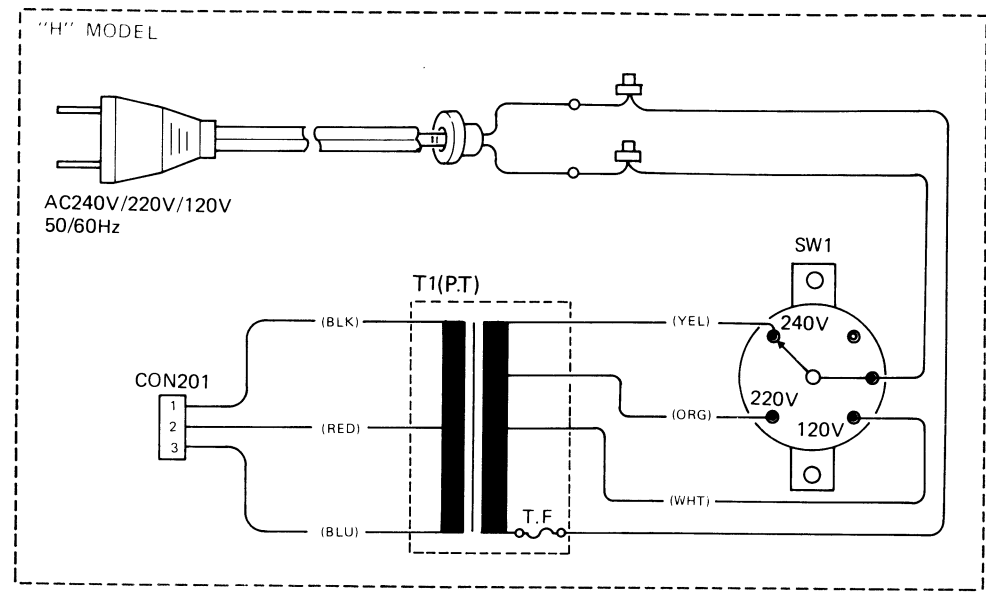
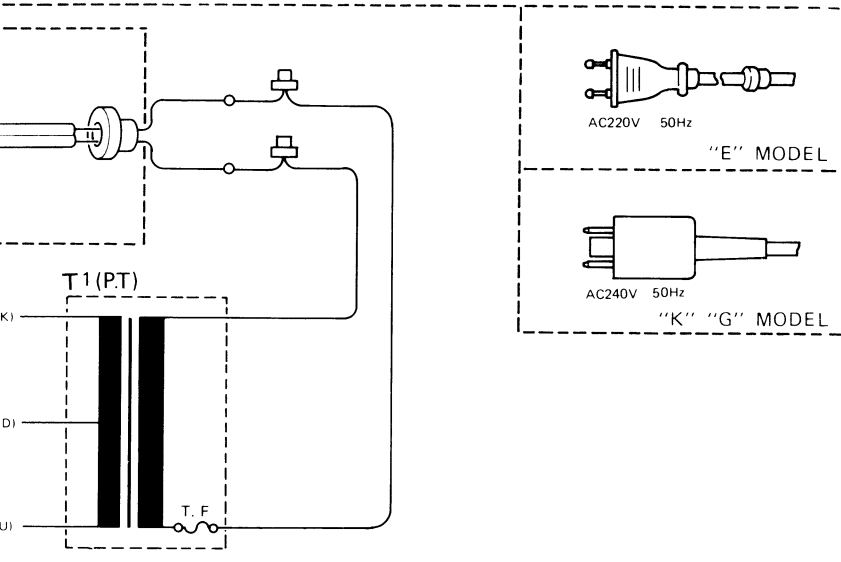

B ANGLE SENSOR C. B

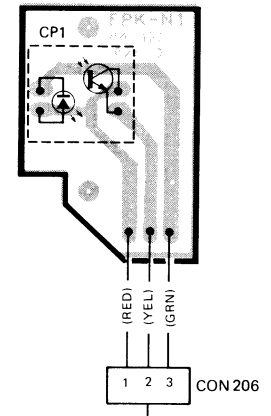

F VOLUME C. B

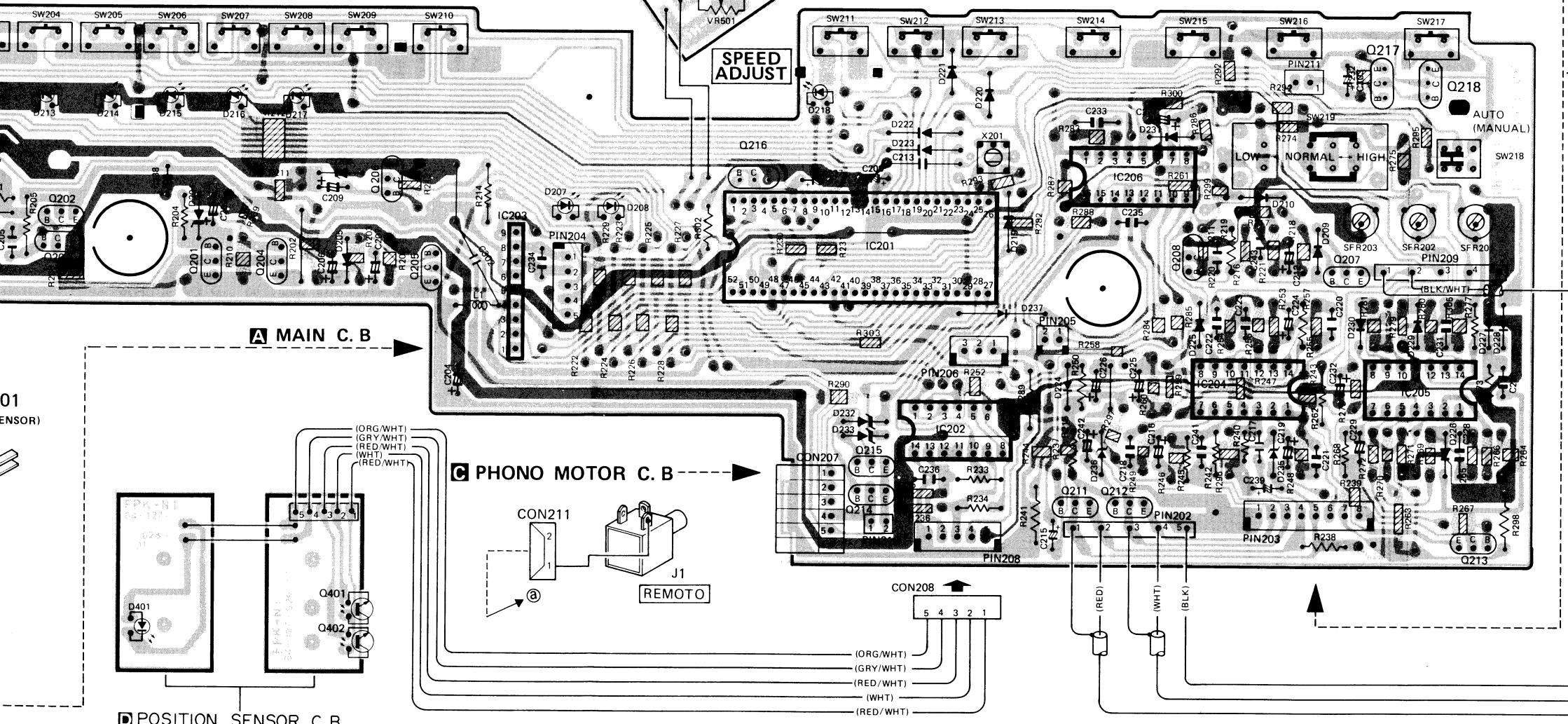

SCHEMATIC DIAGRAM • WIRING-2

1 2 3 4 5 6 7 8 9 10 11 12 13 14 15 16

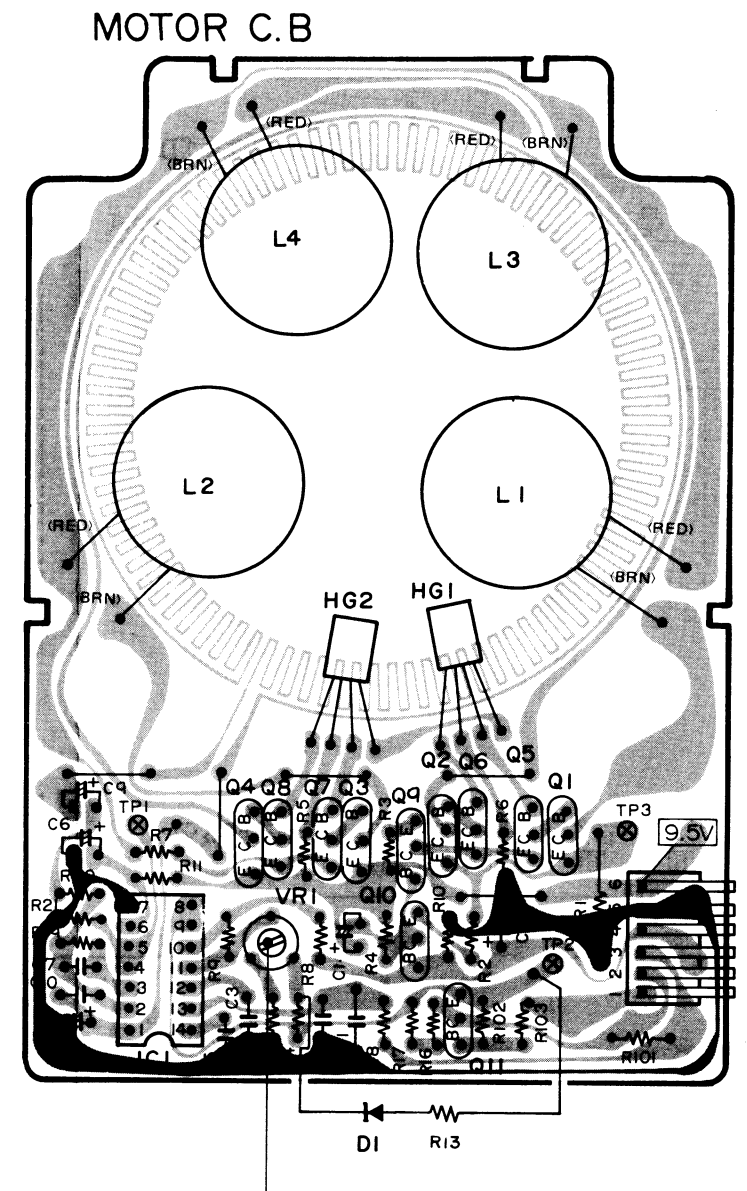
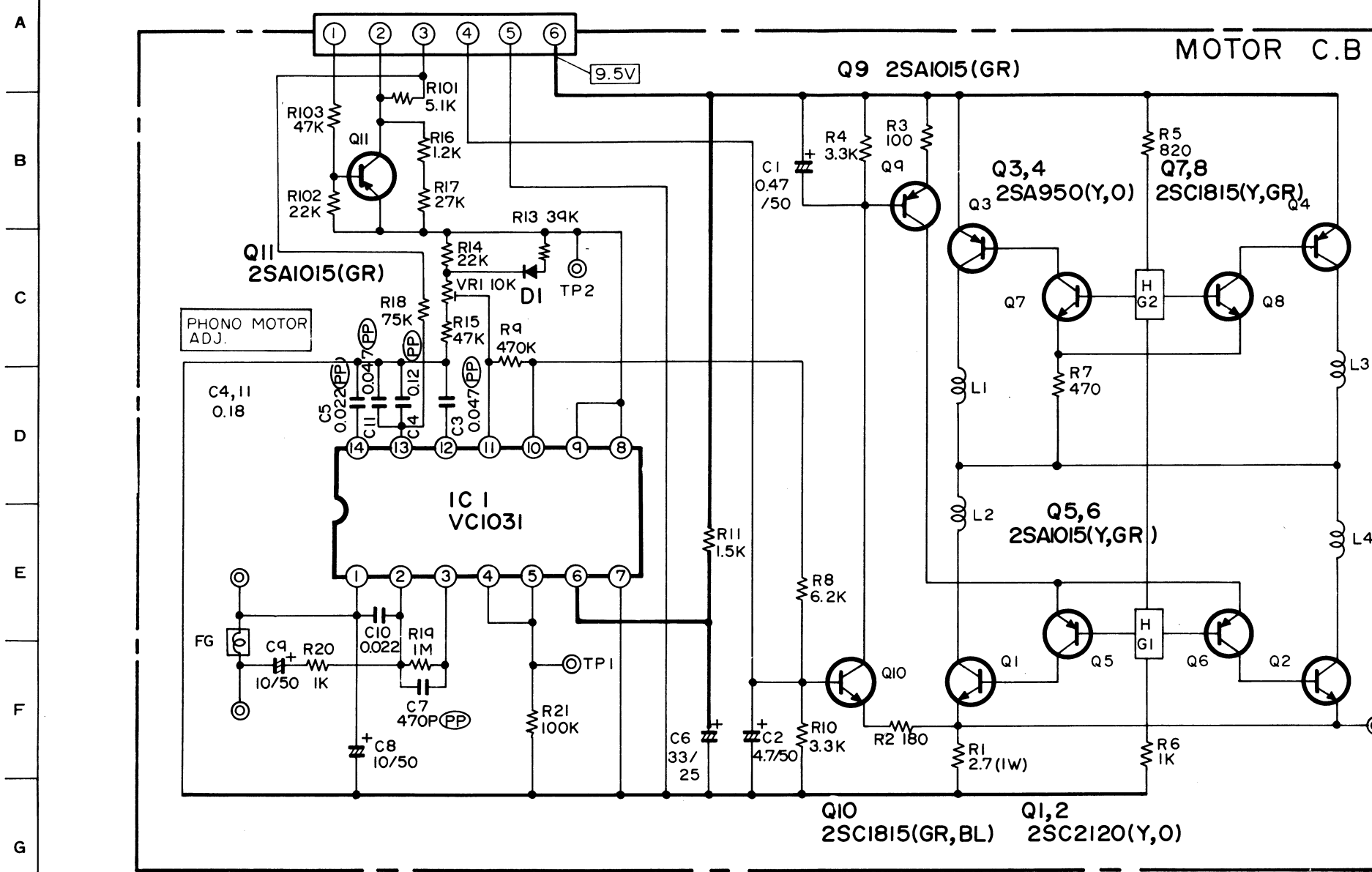

Phonomotor adjustment
How to adjust semi-fixed resistor in the phonomotor board Alternately adjust the speed control volume VR501 and the semi-fixed resistor VR1 on the phonomotor board so that the stroboscope stops with the speed control volume set to the same position during speed selection.

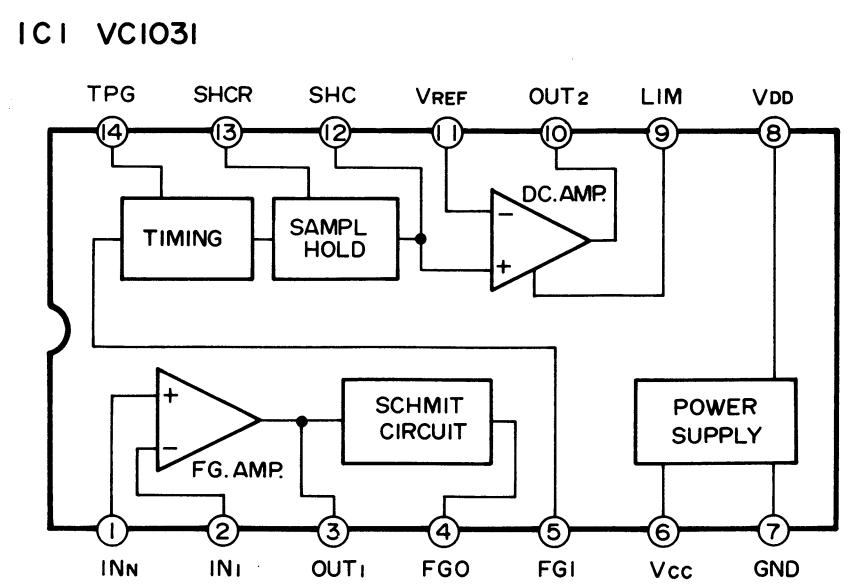

NOTES ■ Earth pattern ■ Others pattern

4 5 6 7 8 9 10 11 12 13 14 15 16 17 18 19

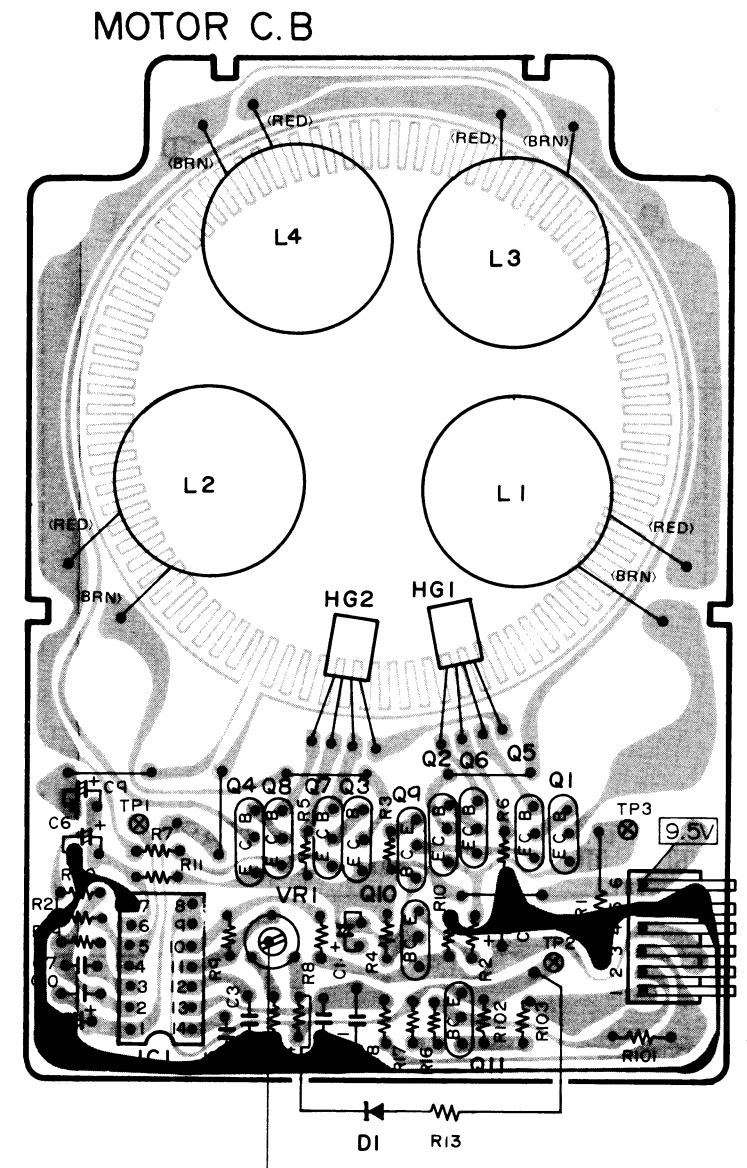
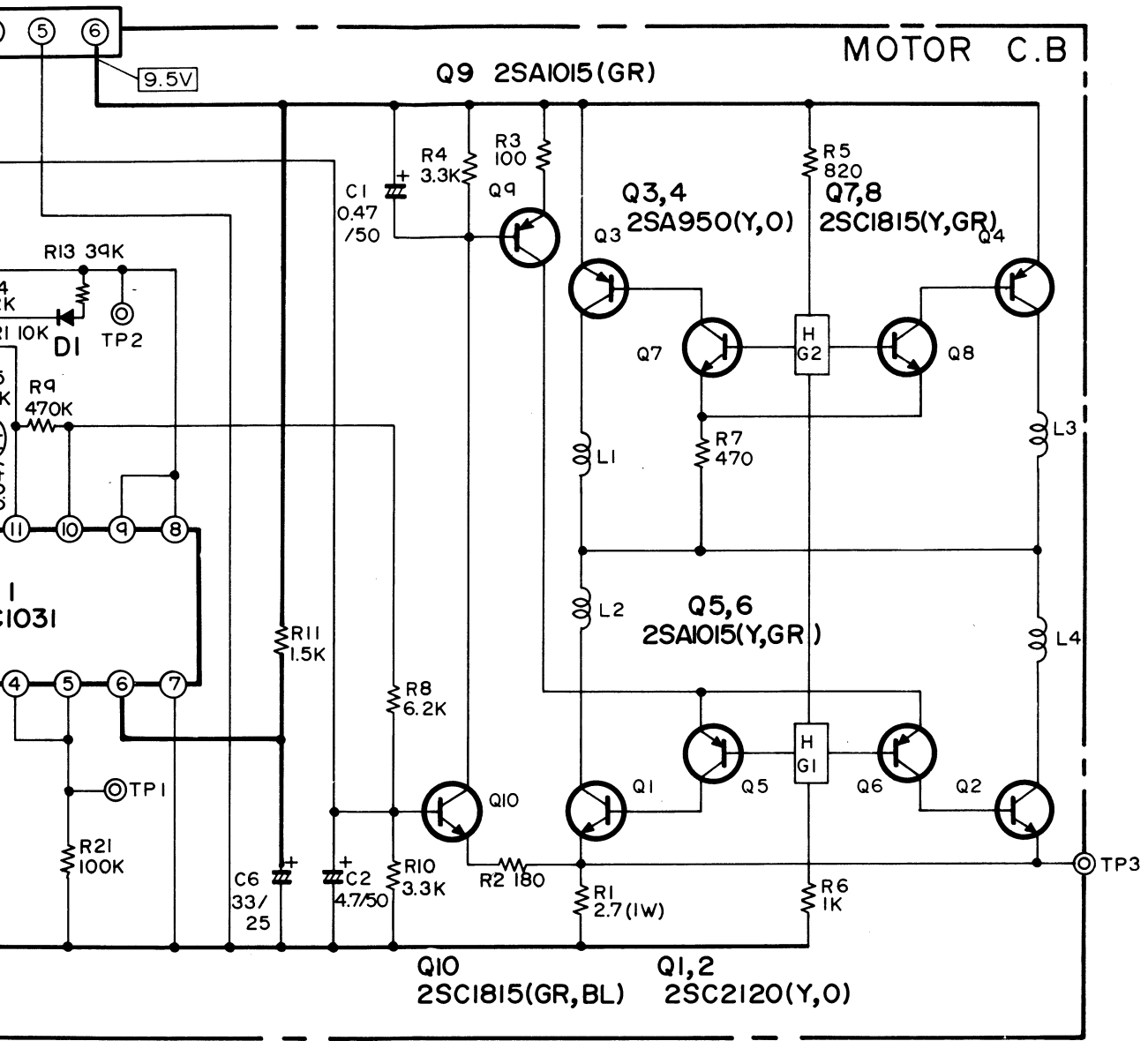

Phonomotor adjustment

How to adjust semi-fixed resistor in the phonomotor board Alternately adjust the speed control volume VR501 and the semi-fixed resistor VR1 on the phonomotor board so that the μ roscope stops with the speed control volume set to the same position during speed selection.

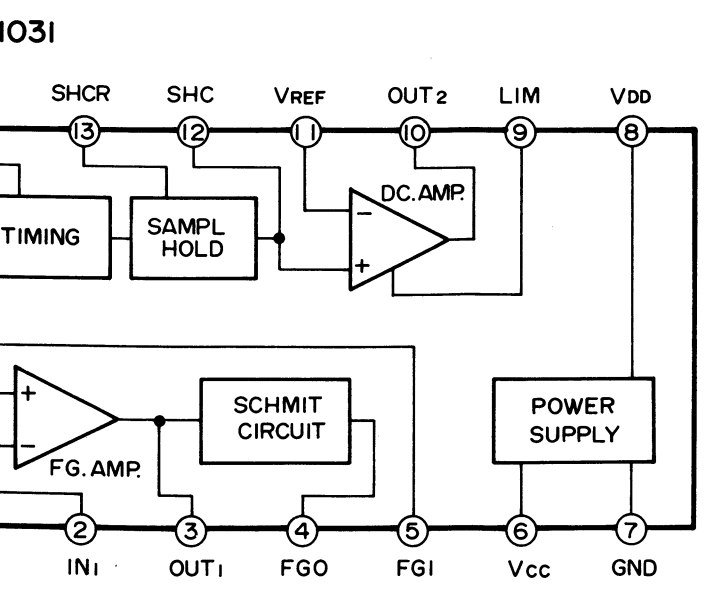

DISASSEMBLY INSTRUCTIONS

Removing Main Cabinet

1) Remove the dust cover and turn-table.
(See Figure-1)

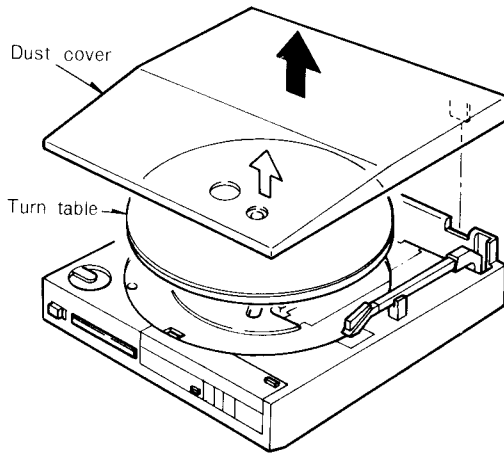

3) Pull out the speed adjustment knob and remove the 7 screws to dismount the main cabinet in the direction of the arrows.
(See Figure-3)

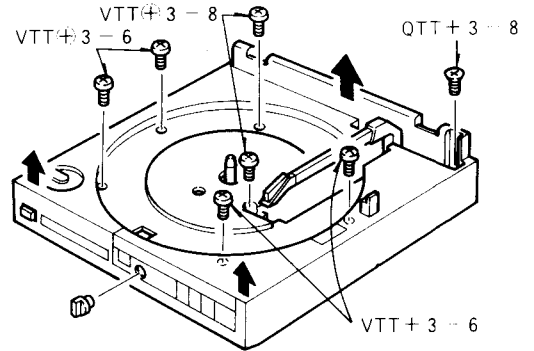

2) After removed the cabinet cover, shift the tonearm to the position as illustrated.
(See Figure-2)

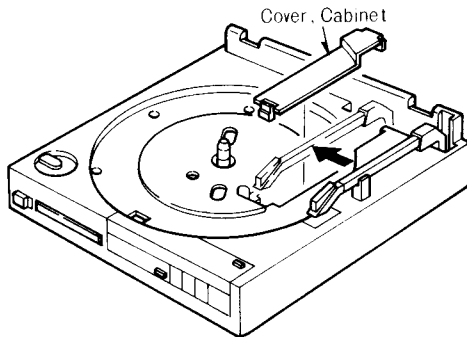

Note) When remove the speed adjustment knob, take care not to scratch it.

Part No.	Description
87-261-167-21	V+4-4
87-341-100-21	UT+3-16
87-081-511-01	VTT+3-6
87-081-512-01	VTT+3-8

EXPLODED VIEW-1

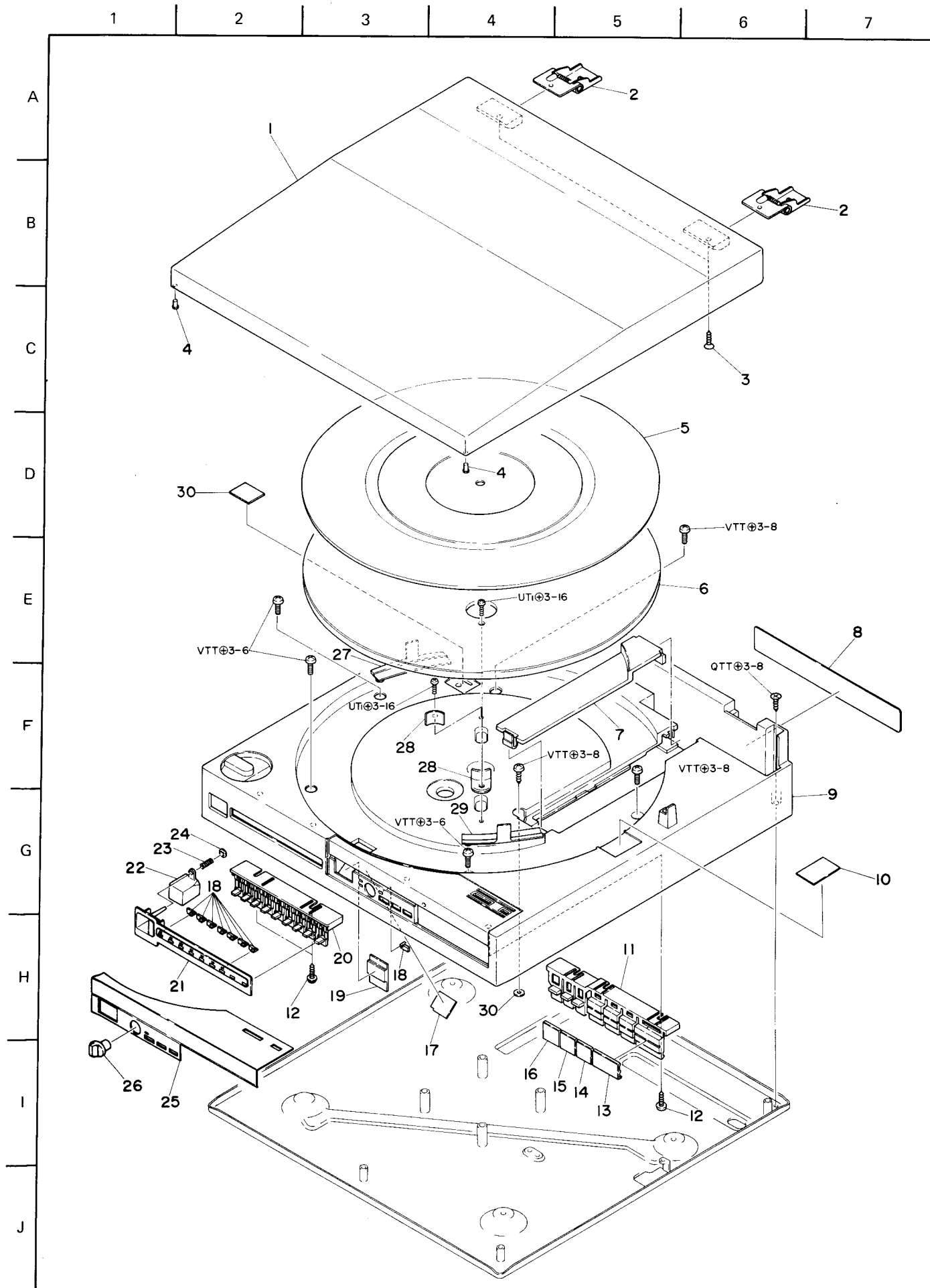

PARTS LIST

MECHANICAL PARTS LIST

■ ※mark in this part list shows exclusive part.
 ■ "★★★" shows unavailable Repair Part.

Ref. No.	Part No.	Part No. Changed to	Description	Common Model	Q'ty	Remark
1- 1 ~ 4	84-127-038-01		Dust cover ass'y	※	1	
1- 1	84-127-037-01		Cover, Dust	※	1	★★★
1- 2	84-128-027-01		Hinge ass'y		2	
1- 3	87-233-094-11		Qr3-6		2	
1- 4	84-128-029-01		Damper		2	★★★
1- 5	84-120-011-11		Rubber sheet	AP-D60	1	
1- 6	84-127-022-01		Turn-table	※	1	
1- 7	84-127-016-01		Cover, Cabinet	※	1	
1- 8	84-127-027-01		Name plate, Spec. (H model only)	※	1	★★★
	84-127-057-01		Name plate, Spec. (HB model only)	※	1	★★★
	84-127-058-01		Name plate, Spec. (UB model only)	※	1	★★★
	84-127-029-01		Name plate, Spec. (E model only)	※	1	★★★
	48-127-056-01		Name plate, Spec. (EB model only)	※	1	★★★
	84-127-030-01		Name plate, Spec. (K model only)	※	1	★★★
	84-127-059-01		Name plate, Spec. (KB model only)	※	1	★★★
	84-127-033-01		Name plate, Spec. (G model only)	※	1	★★★
1- 9 ~25	84-127-036-01		Main cabinet ass'y (H, E, K, G models only)	※	1	
1- 9 ~25	84-127-042-01		Main cabinet ass'y (HB, UB, EB, KB models only)	※	1	
1- 9	84-127-035-01		Cabinet, Main (H, E, K, G models only)	※	1	★★★
	84-127-045-01		Cabinet, Main (HB, UB, EB, KB models only)	※	1	★★★
1-10	84-124-026-01		Name plate	LX-70	1	★★★
1-11	84-127-010-01		Push-key R	※	1	
1-12	87-511-095-21		VFT1+3-8		4	
1-13	84-127-004-01		Cap L (H, E, K, G models only)	※	1	
	84-127-050-01		Cap LB (HB, UB, EB, KB models only)	※	1	
1-14	84-127-007-01		Cap S, R (H, E, K, G models only)	※	1	
	84-127-053-01		Cap SB, R (HB, UB, EB, KB models only)	※	1	
1-15	84-127-006-01		Cap S, F (H, E, K, G models only)	※	1	
	84-127-052-01		Cap SB, F (HB, UB, EB, KB models only)	※	1	
1-16	84-127-005-01		Cap S, VP (H, E, K, G models only)	※	1	
	84-127-051-01		Cap SB, UP (HB, UB, EB, KB models only)	※	1	
1-17	84-124-016-01		Mirror	LX-70	1	★★★
1-18	84-123-016-01		Guide, Light	LX-100	8	★★★
1-19	84-124-009-01		Window A, Strobo	LX-70	1	
1-20	84-127-011-01		Push-Key L	※	1	
1-21	84-127-012-01		Guide, button	※	1	★★★
1-22	84-128-030-11		Knob, POWER (H, E, K, G models only)		1	
	84-128-054-01		Knob, POWER (HB, UB, EB, KB models only)		1	
1-23	84-124-227-01		C-spring, P	LX-70	1	
1-24	87-081-903-01		CS-2		1	
1-25	84-127-003-01		Plate R (H, E, K, G models only)	※	1	★★★
	84-127-048-01		Plate R (HB, UB, EB, KB models only)	※	1	★★★
1-26	82-186-051-01		Knob (H, E, K, G models only)	AD-WX110	1	
	84-127-061-01		Knob (HB, UB, EB, KB models only)	※	1	
1-27	84-124-240-01		Cushion T.T.R	LX-70	1	★★★
1-28	84-124-239-21		Spacer T.T	LX-70	2	★★★
1-29	84-124-243-01		Cushion T.T.L	LX-70	1	★★★
1-30	84-120-038-01		Lid (E, EB, K, KB, G models only)	AP-D60	1	

Ref. No.	Part No.	Part No. Changed to	Description	Common Model	Q'ty	Remark
2- 1	84-127-215-01		Himelon 15-8	※	1	
2- 2	84-124-234-01		MS guide, LED	LX-70	1	
2- 3	84-124-235-21		SP guide, LED	LX-70	1	
2- 4	84-124-012-01		Knob, Sensor	LX-70	1	
2- 5	84-124-013-01		Knob, Speed	LX-70	1	
2- 6	84-123-027-01		Plate, Jack (H, HB, UB models only)	LX-100	1	★★★
	84-123-061-01		Plate, Jack (E, EB, K, KB, G models only)	LX-100	1	★★★
2- 7	87-084-063-01		Nylon rivet 3-5.5 (H, HB, B, UB models only)		1	
	87-084-078-01		Nylon rivet 3-4.5 (E, EB, K, KB, G models only)		1	
2- 8	87-085-165-01		Cord bushing (H, HB models only)		1	
	87-085-184-01		Cord bushing (UB model only)		1	
	87-085-185-01		Cord bushing (E, EB, K, KB, G models only)		1	
2- 9	87-034-956-01		AC power cord (H model only)		1	
	87-034-958-01		AC power cord (HB model only)		1	
	87-034-578-01		AC power cord (UB model only)		1	
	87-034-877-01		AC power cord (E, EB models only)		1	
	87-034-711-01		AC power cord (K, KB, G models only)		1	
2-10	84-127-019-41		Tone arm ass'y	※	1	
2-11	84-124-952-01		Tag, Caution	LX-70	1	★★★
2-12 ~68	84-127-039-11		Bottom cabinet ass'y (H, HB models only)	※	1	
2-12 ~68	84-127-044-01		Bottom cabinet ass'y (UB model only)	※	1	
2-12 ~68	84-127-046-11		Bottom cabinet ass'y (E, EB, K, KB, G models only)	※	1	
2-12	87-081-501-01		VTT+2.6-4		2	
2-13	84-123-238-01		E-spring, Sensor	LX-100	2	
2-14	84-124-209-21		Lever A, Sensor A	LX-70	1	
2-15	87-351-094-01		VT1+3-6		2	
2-16	84-124-222-01		Switch holder A	LX-70	1	★★★
2-17	84-124-204-01		Gear A, Worm	LX-70	1	
2-18	87-261-071-21		V+2.6-4		1	
2-19	84-124-242-01		T-spring, Wire	LX-70	1	
2-20	84-124-223-01		Wire rope	LX-70	1	★★★
2-21	84-124-228-01		C-spring, Cam A	LX-70	1	
2-22	84-124-207-11		Up-down, Cam A	LX-70	1	
2-23	84-124-219-01		Up-down, Shaft A	LX-70	1	★★★
2-24	84-124-201-31		Mechanism chassis ass'y	LX-70	1	★★★
2-25	84-127-201-01		Cover, Motor	※	1	★★★
2-26	84-127-206-01		Pulley S, Motor	※	1	
2-27	82-541-268-01		Rubber belt, Counter		2	
2-28	84-127-202-01		Plate A, MASK	※	1	★★★
2-29	84-124-205-11		Holder A, Pipe	LX-70	2	
2-30	87-081-511-01		VTT+3-6		10	
2-31	84-124-206-11		Holder B, Pipe	LX-70	2	
2-32	84-124-214-01		Pipe A	LX-70	1	★★★
2-33	84-124-215-01		Pipe B	LX-70	1	★★★
2-34	84-124-211-01		Holder A, MASK	LX-70	1	
2-35	87-038-039-01		Wire binder		2	★★★
2-36	87-261-100-21		V+3-16		1	
2-37	87-391-717-01		Nut 3-2.4		1	
2-38	84-124-665-01		Synchrte cord	LX-70	1	
2-39	84-199-606-01		Pin cord		1	
2-40	87-085-101-01		Cord bushing		1	
2-41	87-084-063-01		Nylon rivet 3-5.5		1	
2-42	84-123-026-01		Plate A, Jack	LX-100	1	★★★
2-43	87-441-005-01		STE-2		4	
2-44	87-071-013-11		Pulley A		3	
2-45	84-127-041-01		Bottom cabinet F ass'y (H, HB models only)	※	1	★★★
2-46	84-124-246-01		Sheet 5-2-1.9	LX-70	1	★★★
2-47	84-123-060-01		Rubber cushion 4-10-1.5	LX-100	1	★★★
2-48	84-124-238-01		Screw	LX-70	1	
2-49	84-120-025-11		Rubber foot ass'y		4	
2-50	87-081-483-01		Motor screw, M2.6		2	
2-51	87-087-029-01		Rubber cushion		2	★★★
2-52	84-127-205-01		Pulley L, Motor	※	1	
2-53	84-123-206-01		Shaft A, Worm	LX-100	1	★★★
2-54	84-124-231-11		Motor holder ass'y	LX-70	1	★★★
2-55	84-123-309-01		W3.2-8	LX-100	2	
2-56	84-123-205-61		Gear B, Worm	LX-100	1	
2-57	87-067-039-01		PW2.3-8-0.25		1	
2-58	87-067-020-01		VTT+3-4		3	
2-59	84-123-204-01		Gear A, Pulley	LX-100	1	
2-60	87-441-011-01		STE-4		1	
2-61	84-123-236-01		E-spring, Solenoid	LX-100	1	
2-62	84-124-225-01		Lead holder C	LX-70	1	★★★
2-63	84-127-209-01		Plate A, Motor (H, HB, E, EB, K, KB, G models only)	※	1	★★★
	84-127-216-01		Plate, Motor (UB model only)	※	1	★★★
2-64	84-127-210-01		Plate B, Motor	※	1	★★★
2-65	84-127-212-01		Himelon 100-8 (H, HB, E, EB, K, KB, G models only)	※	1	★★★
	84-127-217-01		Himelon 100-8 (UB model only)	※	1	★★★
2-66	84-127-213-01		Himelon 50-8	※	1	★★★
2-67	84-127-211-01		Plate C, Motor	※	1	★★★
2-68	84-124-224-01		Holder B, Front	LX-70	1	★★★

ACCESSORIES/PACKAGE LIST

Ref. No.	Part No.	Part No. Changed to	Description	Common Model	Q'ty	Remark
1	84-127-854-01		Printed indiv., Packing	※	1	★★★
2	84-127-852-01		Cushion F. Printed indiv.	※	1	★★★
3	84-127-853-11		Cushion R. Printed indiv.	※	1	★★★
4	84-127-855-01		Carton. Outer (H, HB, E, EB, K, KB, G models only)	※	1/2	★★★
5	84-127-856-01		Carton. Outer (UB model only)	※	1/2	★★★
6	84-127-857-01		Pad, Corrugated board	※	1	★★★
7	87-051-171-11		Poly-vinyl sack (for AC power cord & Pin code)		1	★★★
8	84-124-857-01		Sheet, Corrugated board	LX 70	1	★★★
9	84-124-858-01		Sheet, Foamed mat	LX 70	1	★★★
10	84-124-861-01		Sheet, Foamed mat	LX 70	1	★★★
11	87-056-651-01		Color label, Black (HB, UB, EB, KB models only)		1	★★★
12	84-127-904-01		Instructions booklet	※	1	
13	87-051-171-11		Poly-vinyl sack (for instruction)		1	★★★
14	87-056-009-51		Distributors list (H, HB, E, EB, K, KB, G models only)		1	★★★
15	87-056-050-01		Safety instruction (UB model only)		1	★★★
16	87-056-045-01		Guarantee card (UB model only)		1	★★★
17	87-056-059-01		Guarantee card (G model only)		1	★★★
18	87-056-084-01		Limited, Warranty (HB model only)		1	★★★
19	87-056-008-11		Label, AC power cord (K, KB models only)		1	★★★
20	84-190-965-01		45 adapter (H, E, K, G models only)		1	
21	84-190-978-01		45 adapter S (HB, UR, EB, KB models only)		1	
22	87-032-845-01		Siemens plug (H, HB models only)		1	

AIWA Co., Ltd. Tokyo Japan