

SERVICE MANUAL

COMPUTERIZED FULLY AUTOMATIC
DIRECT DRIVE TURNTABLE

SANSUI FR-D55



● SPECIFICATIONS

Type	Two-speed direct-driven
Speeds	33-1/3, 45rpm
Platter	Aluminum alloy die-cast 315mm (12-13/32") diameter
Motor	FG Servo DC Motor
Wow and flutter	0.025% (W.R.M.S.)
S/N	Better than 60 dB (IEC-B)
Rumble	Better than 72 dB (DIN-B)
Tonearm	
Tonearm length	220mm (8-11/16")
Overhang	17.5mm (3/4")
Applicable cartridge weight	4 to 9g
Dimensions	440mm (17-5/16") W 127mm (5") H 374mm (14-11/16") D
Weight	6kg (13.2 lbs.) net 7.4kg (16.3 lbs.) packed
Power consumption	38W

● The power voltage is adjusted to the one of the area where you bought the unit.

Specifications of the cartridge (applicable only to the units with cartridge)

Model SC-50

Type	Induced magnet
Frequency response	10~20,000Hz
Output voltage	3.0mV per channel (1,000Hz, 35.4mm/sec)
Load impedance	47k Ω
Tracking force	2.5g
Stylus	0.6mil, diamond spherical (SN-50)

Model SV-101

Type	Dual magnet
Frequency response	10~20,000Hz
Output voltage	2.5mV per channel (1,000Hz, 35.4mm/sec)
Load impedance	47k Ω
Tracking force	2g
Stylus	0.6mil, diamond spherical (SN-101)

Model SV-202

Type	Dual magnet
Frequency response	10~20,000Hz
Output voltage	2.5mV per channel (1,000Hz), 35.4m/sec)
Load impedance	47k Ω
Tracking force	2g
Stylus	0.6mil, diamond spherical (SN-202)

* Design and specifications subject to changes without notice for improvements.

Sansui

SANSUI ELECTRIC CO., LTD.

1. OPERATION

The FR-D55 is a computerized full automatic music selection turntable in which a mechanism that can automatically select any music on a record disc at random.

Refer to XR-Q11 SERVICE MANUAL, for basic operations which are almost equal to this model.

The control circuits for FR-D55 can mainly be divided into a servo circuit to control a DD motor and a microcomputer and its peripheral circuit to mainly control a tonearm.

Refer to FR-D45 SERVICE MANUAL, for operation of the servo circuit, since the operation is entirely the same as in the FR-D45.

1-1. Basic circuit configuration for full automatic operation (See Block Diagram on Page 2.)

A. Microcomputer

The microcomputer μ PD546C-181 controls the operations of the tone arm, lifter, and DD motor in such a way that every control signal is output to the corresponding output port after each of signals applied to the input ports has been executed in accordance with a program stored in the microcomputer memory.

The microcomputer becomes enable only when the output ports are at H level in potential; in other words, every circuit connected to pins (at H level) of the microcomputer operates.

B. Input peripheral circuits for the microcomputer

1. Control switches

These are manual operation switches to perform the full automatic operation. Since the control switches are dynamic-connected to the ports of the microcomputer, if a control switch is pushed, two input/output pins are connected to each other in the microcomputer and thereby the microcomputer begins to operate. (See Block Diagram.)

2. A sensor and the sensor circuit

In operation with the B sensor, the A sensor detects the tonearm positions necessary for automatic operation. In other words, the A sensor detects the lead-in position of a 30cm- or 17cm-size record disc and also detects whether the tonearm rests on the arm rest ($A \times B = 1$) or not ($A \times B \neq 1$).

The tonearm positions ($A \times B = 1$ and $A \times B \neq 1$) have the following relations to the start/stop switch:

- If START/STOP switch is set to start (The turntable is at a stop)

Arm Position	Lifter Position	Operation of Turntable	Automatic Operation
On the rest ($A \times B = 1$)	Up ($D = 1$)	Rotates after 200ms	In-operation
Same as above	Down ($C = 1$)	Immediately rotates	In-operation after $D = 1$ in CW
On the record disc ($A \times B \neq 1$)	Up ($D = 1$)		To $C = 1$ in CW
Same as above	Down ($C = 1$)		

- If START/STOP switch is set to stop (The turntable is in motion and also in automatic operation.)

Arm Position	Lifter Position	Operation of Turntable	Automatic Operation
On the rest ($A \times B = 1$)	Up ($D = 1$)	Immediately rotates	
Same as above	Down ($C = 1$)		
On the record disc ($A \times B \neq 1$)	Up ($D = 1$)	Stops at point AB	Arm return
Same as above	Down ($C = 1$)		Arm return

- If START/STOP switch is set to stop (The turntable is in motion and also in automatic operation.)

Arm Motion Status	Automatic Operation	Operation of Turntable
During up motion ($A \times B = 1$)	Out of automatic operation at $D = 1$	Immediately stops
During up motion ($A \times B \neq 1$)	Arm return after $D = 1$	Immediately stops at point AB
During horizontal motion ($A \times B = 1$)	Immediately out of automatic operation	Immediately stops
During horizontal motion ($A \times B \neq 1$)	Arm return in CCW \rightarrow CW or in CCW	Stops at point AB
During down motion ($A \times B \neq 1$)	Arm return after $D = 1$	Same as above
During return motion	Disable	

Note: In the above lists, $A \times B = 1$, $D = 1$, and $C = 1$ mean the states in which the sensors B, C, and D are detecting the corresponding signals, respectively, on the timing chart. CW means that the micromotor rotates clockwise; CCW means that the micromotor rotates counterclockwise. Refer to the respective sections for operations of the sensors A, B, C, D and the micromotor.

The signal detected by A sensor is applied to the input terminal 33 of the microcomputer through fIC_{01b} and fIC_{01c} .

3. B sensor and the sensor circuit

In cooperation with the A sensor, the B sensor detects the tonearm position and the end detection signal in the record lead-out groove after finishing over play.

The signal detected by the B sensor is applied to the input terminal 34 of the microcomputer through transistor fQ_1 , and fC_{01d} .

4. C sensor, D sensor and the sensor circuits

The C and D sensors comprise a lifter cam and the micro-switches, respectively. The C sensor detects the down-position of the lifter; the D sensor detects the up-position of the lifter.

In the both sensors, the terminal 2 of each micro-switch is shorted to the ground whenever the lifter states are detected.

5. E sensor and F sensor

The E and F sensors mounted within the head shell feed into the microcomputer the signals necessary for automatic disc size selection and automatic music selection. In other words, in order to implement complex full automatic operations, both the sensor signals are fed into the computer after being discriminated into E_2 , E_3 , F_1 , and F_2 , respectively, through appropriate circuits.

The arrangement of the E and F sensors is shown in Fig. 1-1, and E sensor is called a leading sensor because E sensor first detects the signal.

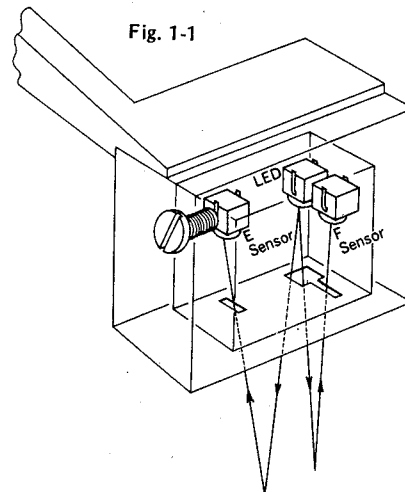

2. BLOCK DIAGRAM

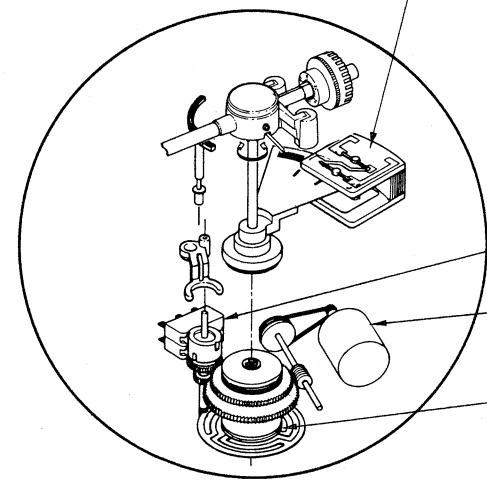
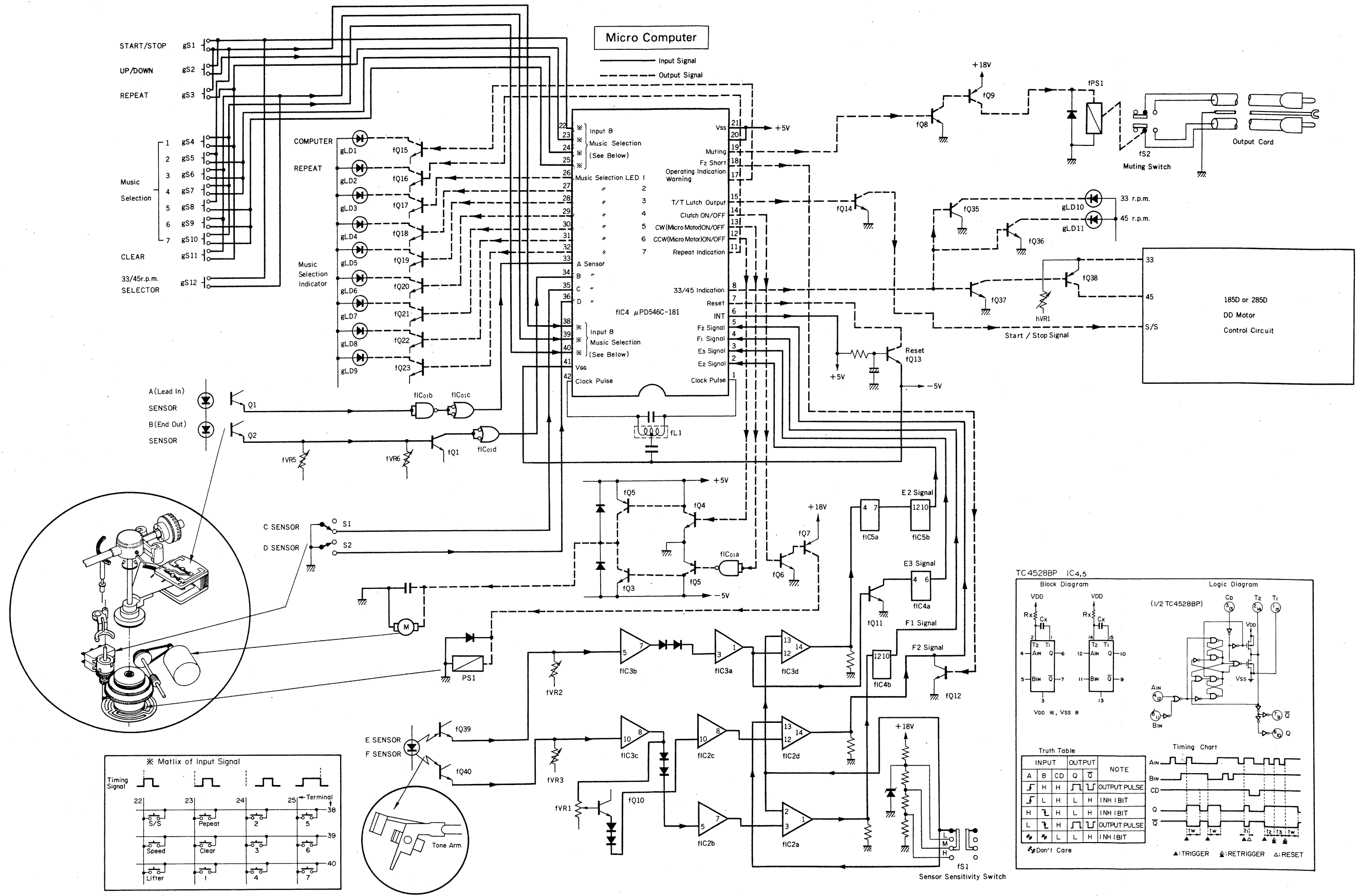

※ Matrix of Input Signal

Timing Signal	Terminal
S/S	22
Repeat	23
Speed	24
Lifter	25
Clear	38
1	39
2	40
3	36
4	37
5	38
6	39
7	40

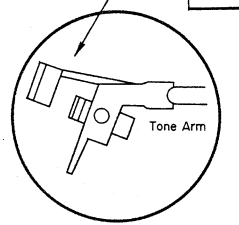

TC 4528BP IC4,5

Block Diagram

Logic Diagram

Truth Table

INPUT	OUTPUT	NOTE
A B CD	Q Q	OUTPUT PULSE
H H H	L L L	INH I BIT
L L L	H H H	INH I BIT
H H H	L L L	OUTPUT PULSE
L L L	H H H	INH I BIT

Timing Chart

▲: TRIGGER ▲: RETRIGGER ▲: RESET

1) <E₂ Signal>

The E₂ signal is a signal to count the necessary number of modulated tracks so that the tonearm may come down onto a desired automatic music selection operation.

At the moment when the E sensor first detects a desired lead-over groove (marker space) and the E₂ signal next rises up (↑), the tonearm stops moving and begins coming down onto it.

As shown in Block Diagram, the circuit includes a monostable multivibrator to generate a pulse with a fixed pulse width, and the pulse is applied to the microcomputer.

2) <E₃ signal>

The E₃ signal is a signal to detect the disk sizes and the presence or absence of a record disc. When the E sensor detects the circumference of a record disc during the lead-in motion of the tonearm, E₃ signal is generated. When the E₃ signal is generated (E₃ = 1) and the A sensor signal rises up (↑), the disc size selection of 30 and 17 cm is achieved. Also, while the A sensor generates the signal (A = 1), if E₃ signal is generated, the disc selection of 30 and 17 cm is achieved in the same way.

If E₃ = 1 and A = 1 are not attained at the same time, this indicates that no record disc is on the platter.

In the case of whole-music play, the tone arm comes down by the E₃ signal or the rise up (↑) of the A signal. Also, in automatic music selection operation, the sizes and the presence or absence of a record disc are detected. If the first selected music is in the first music section on a record disc, the operation is the same as in the whole-music play operation.

The circuit is shown in Block Diagram. The detection sensitivity of the circuit generating E₃ is set to be higher than that of the circuit generating E₂. In addition, the sensitivity of the E sensor is adjustable with a variable resistor, and the delay time of the E₂ signal is also adjustable.

3) <F₁ signal>

The F₁ signal is a signal to perform muting and to control F₂S (a signal to control F₂ signal) in automatic music selection operation.

In the case when the tonearm stops in a lead-over groove (a marker space) for a music on or after the second modulated tracks during automatic music selection, F₁ = 1 is obtained; in the case when the tonearm stops in a modulated groove, F₁ = 0 is obtained.

As shown in Block Diagram, the circuit is made up of a sensor, a DC amplifier, a band pass filter, a comparator, and a monostable multivibrator.

4) <F₂ signal>

The F₂ signal is a signal generated when the F sensor detects the lead-over groove (marker space) while the stylus is on a record disc, that is, during tracing, while the E₂, E₃ or F₁ is detected only when tonearm rises up.

The functions of the F₂ signal are as follows:

- (1) To count the numbers of music tracks, by using the rise-up (↑) of the F₂ signal, in order to perform automatic music selection.
- (2) To release the muting when the lead-in horizontal motion of the tonearm stops in automatic music selection.
That is to say, the muting is released by the rise-up (↑) of the F₂ signal if F₁ = 0.
- (3) To detect the end of the last track during automatic music selection. When the last music on a record disc is selected, the tonearm begins to return immediately after the last lead-over groove (lead-out groove) is detected by the rise-up (↑) of the F₂ signal.

6. Music sensitivity switch

Complex and accurate operations are required for the automatic music selection on a turntable. The difference in pitch between the lead-over grooves (marker spaces) among various discs or the like may result in an error operation such as a misplacing of the tonearm lifter-down position. Therefore, a sensor sensitivity switch is necessary for adjusting the sensitivities of E₂, F₂, and F₁ signals at the same time.

In this circuit as shown in Block Diagram, the reference voltage applied to the comparators is adjusted into three levels by using the sensor sensitivity switch.

1-2. Basic Operating of Automatic Music Selections

Switch Play #1

When pushing SW ③, during non-programmed play.
(Program is cleared after return-motion.)

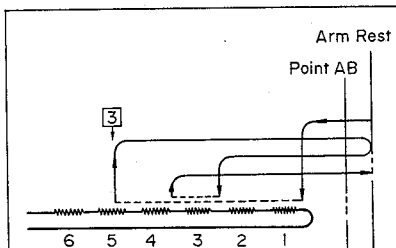

Switch Play #2

When pushing SW ② or clear, during play of track ②.
(The remaining record tracks is sifted to standard order.)

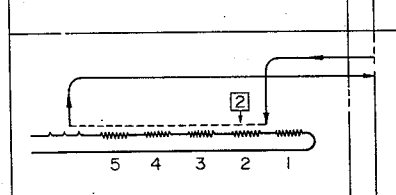

All Clear

②→③→⑤→⑤/S
S/S
When pushing SW ⑤/S, during play of a track.
(Program clear)

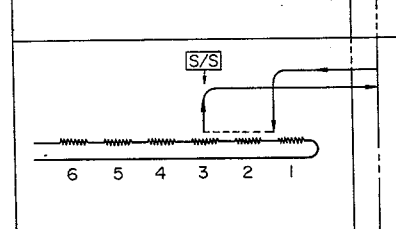

Random Cue

⑥→②→③→⑤→⑤/S
→ S/S
(Program is cleared after return-motion.)

Random Cue

(Repeat Play)
⑤→②→③→REPEAT
→⑤/S

Skip Play

②→③→⑤→⑤/S
S/S
When pushing SW, during play of track ③.
(Program is cleared after return-motion.)

Mistaken Pushing Erroneous Detection

(Same way if not a disc.)
⑤→⑤/S
(Warned flickering, repeat released, program latched)

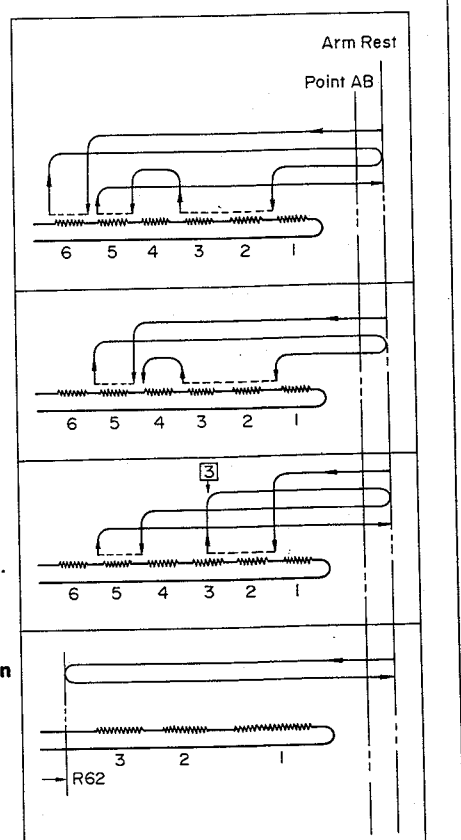

C. Output peripheral circuits for the microcomputer

1. Micromotor control circuit

When the micromotor rotates clockwise, the tonearm makes a return motion and the lifter makes an up-and-down motion. On the other hand, when the micromotor rotates counterclockwise, the tonearm makes a lead-in motion and, in addition, the lifter makes an up-and-down motion when the lifter switch is pushed again while the lifter is in motion.

2. Plunger control circuit

The plunger engages a clutch plate with a TA drum in the automatic mechanism assembly, and the micromotor drives the arm and the slit plate.

To control the plunger, the output from the microcomputer output pin No. 14 is used through the transistors fQ_6 and fQ_7 .

3. 33/45 rpm selector and the indicator

The 33/45 rpm selector controls the output from the microcomputer output pin No. 8. The output from the pin No. 8 is supplied to the DD servo circuit through fQ_{37} and fQ_{38} (33/45 speed selection) to switch the divide ratio. In addition, two driver transistors are also connected to the pin No. 8. One is fQ_{35} to drive the 33rpm indicator LED $gLD10$, and the other is fQ_{36} for the 45rpm indicator LED $gLD11$.

The 33rpm indicator LED is turned ON when the output signal is applied to Pin No. 8, and in other states, the 45rpm indicator LED is kept turning ON.

4. DD motor control circuit

If the START/STOP switch is pushed when the platter is in the stop mode, H-level is applied to the microcomputer output pin No. 15, and is supplied to the transistor fQ_{14} . And the fQ_{14} short the s/s terminal of the DD motor unit to the ground, then the platter begins to rotate.

5. Music selection indicator circuit

In automatic music selection operation, this circuit is used to store selected track into the microcomputer memory and to indicate them.

During play, an indicator for a music which is now in the play flickers as follows:

- 1) When the tonearm lead-in motion is stopped in a modulated groove, the indicator begins to flicker at the moment when the lead-over groove (the marker space) is detected (by the rise up (\uparrow) of F_2 signal).
- 2) When the tonearm is stopped in a lead-over groove, the indicator begins to flicker at the moment when the micromotor stops (by the trailing edge (\downarrow) of CCW signal.)
- 3) During the sequential music play, the indicator begins to flicker at the moment when the lead-over groove is detected. (by the rise-up (\uparrow) of F_2 signal.) In these operations of above (1), (2) and (3) the flickering period of time is 1.5sec.

6. Computer operation indicator circuit

The output generated from the computer output pin No. 17 drives the transistor fQ_{15} so as to perform switching action for flickering indication.

The indicator is flickered, only when the output level of CW or CCW is "1", with a periodic time of 2.5Hz. In addition, in the case of a miss program such that only a track number which is not included on a record disc is selected or in the case of the absence of a record disc, the indicator begins to flicker with a periodic time of 9Hz from when the tonearm begins to return. This warned flickering is kept for 20sec, but can be released by turning the AC switch OFF, the CLEAR switch ON, START/STOP switch ON, or when the tonearm passes through point AB in manual lead-in operation.

7. Muting circuit

The muting circuit is a circuit to short the outputs of the turntable, where necessary.

The circuit configuration is shown in Block Diagram. The plunger driver circuit is provided with fQ_8 , fQ_9 and fPS_1 to turn the muting operation ON.

The conditions under which the muting is operated are described below:

- 1) In automatic music selection operation and manual lifter operation, if the lifter is down ($C = 1$), the muting is OFF; if the lifter is up ($C \neq 1$), the muting is ON.
- 2) In automatic music selection operation (See Timing Chart 1), when the tonearm lead-in horizontal motion is stopped, if $F_1 = 1$ (the stylus is in a marker space) the muting is turned OFF 1.0 sec after the lifter begins to come down ($D = 1 \rightarrow 0$); if $F_1 = 0$ (the stylus comes down in a modulated groove) the muting is turned OFF at the moment when the marker space is detected by the rise up (\uparrow) of F_2 signal.

8. F_2S generator

This generator is a circuit to generate a F_2S signal to short the F_2 signal so that the signal can not be input to the microcomputer.

The F_2S (F_2 -shorting signal) is the signal to prevent error operation caused by detecting many F_2 signals in the lead-over grooves (marker spaces). In other words; this circuit is provided to remove unnecessary F_2 signals from among a number of detected F_2 signals.

In this circuit as shown in Block Diagram, the output from the computer pin No. 18 is applied to fQ_{12} , so that the F_2 output is shorted. Referring to Fig. 1-3, the conditions under which the F_2S signal are described below.

Fig. 1-2

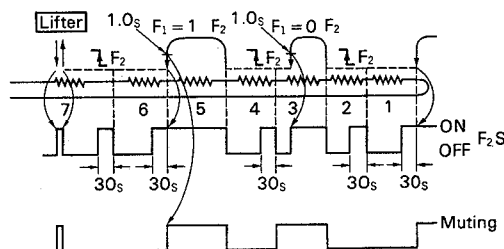

- 1) The first music is selected on a record disc and then the F_2S signal is turned off 30sec after the lead-in operation is completed ($C = 0 \rightarrow 1$).
- 2) A music on and after the second modulated track on a record disc is selected, and in the case when the lead-in operation is completed, the F_2S signal operates, in accordance with the position at which the tonearm horizontal motion is stopped, as follows:
 - a) If the stylus tip is in the modulated groove ($F_1 = 0$), the F_2S signal is turned OFF for 1.0sec after the tonearm comes down ($D = 1 \rightarrow 0$).
 - b) While the stylus is tracing the groove, the F_2S signal is turned ON for 30sec after the rise-up (\uparrow) of the F_2 signal is detected.
 - c) If the stylus comes down onto the marker space ($F_1 = 1$), the F_2S signal is turned OFF for 30sec after the tonearm comes down ($C = 0 \rightarrow 1$).
- 3) In the case when the music are played continuously in automatic music selection, the F_2S signal is turned ON for 30sec after the F_2 signal rises up in the marker space.
- 4) In the case when music selection is erased while the F_2S signal is ON for 30sec, and next when the subsequent music selection operation is made, the state in which the F_2S signal is turned ON for 30sec is released.
- 5) In the case when the lifter is manually operated in automatic music selection play, the F_2S signal is turned ON at $C = 0$ and OFF at $C = 1$.

At a point 50ms later than the horizontal motion stop position (where CW changes from 1 to 0), the computer detects whether the F_1 signal is "1" or "0".

1-3. Microcomputer Timing Chart

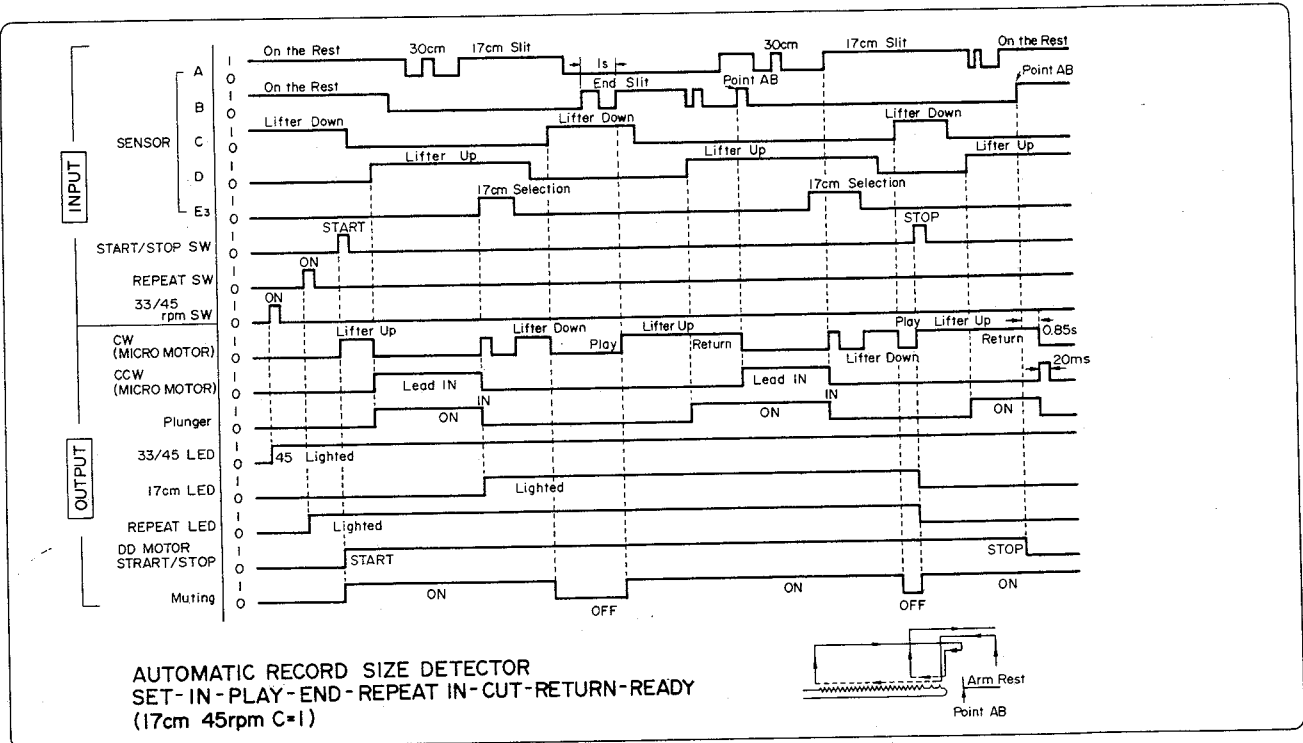
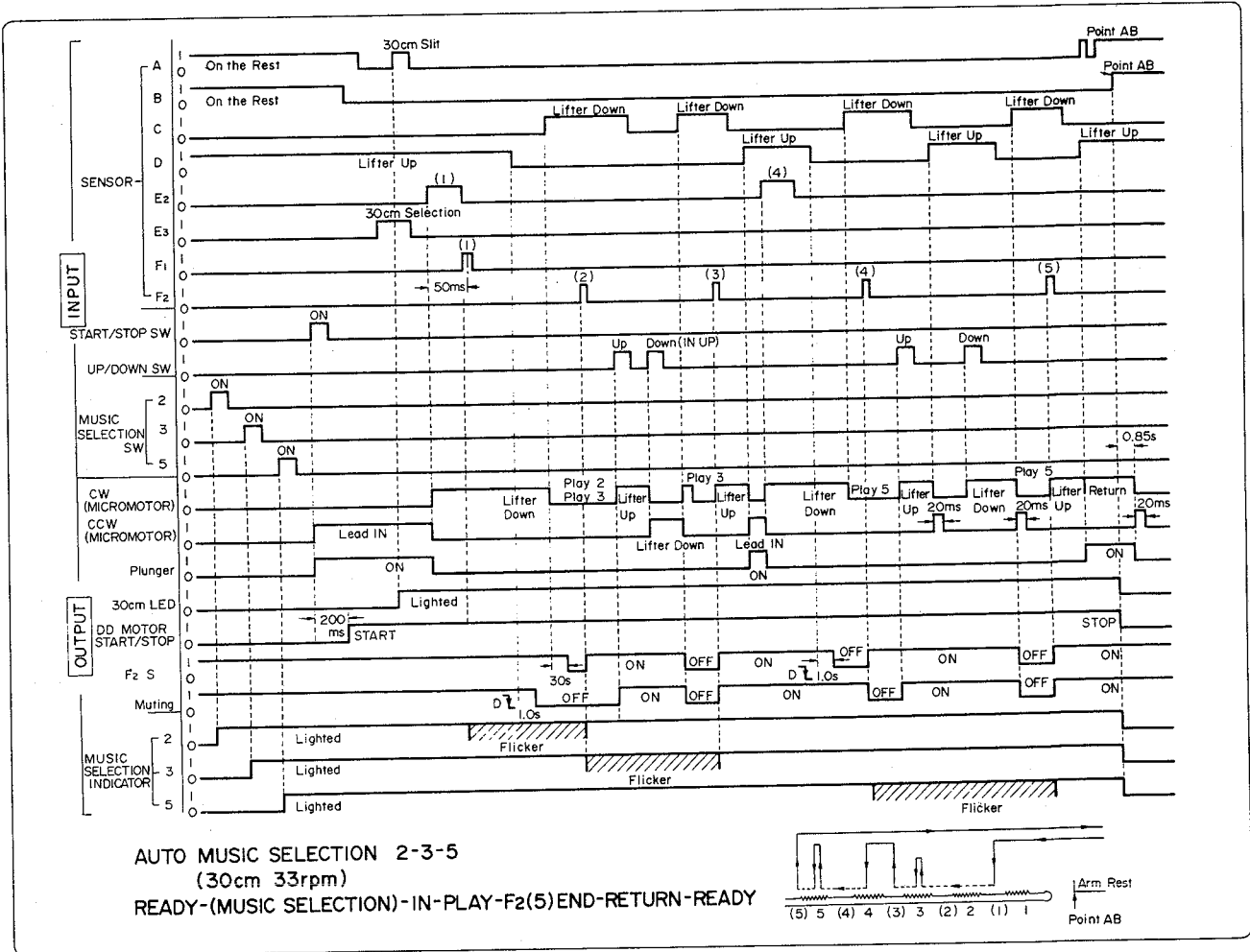

3. ADJUSTMENT (See Top View on Page 12)

3-1. Adjustment of Screen Plate Installation Position

Adjust the position whenever the tonearm is replaced. With the tonearm placed on the arm rest, install the screen plate to the tonearm shaft, as shown in Figs. 3-1 (A) and (B).

Fig. 3-1 Installation of Screen Plate
(A) Side View of Screen Plate

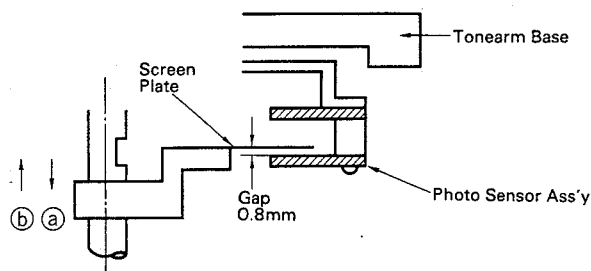

(B) Bottom View of Screen Plate
Note: Tonearm is placed on its rest

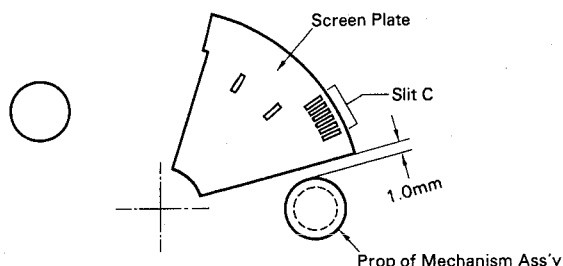

3-2. Adjustment of B Sensor Output

A. Output level adjustment

- 1) Connect the ⊕ terminal of an oscilloscope to the TP2 of S0070 and the ⊖ terminal to the TP4 (GND), and set the selector switch DC/AC to DC and the test ranges to 2V/div and 10msec/div.
- 2) Shift the tonearm by hand to the lead-out groove on the record disc, and slowly move the tonearm right and left in such a way that it takes about two seconds for the slit C of Fig. 3-1 to pass through between the LED and the phototransistor.
- 3) During this movement, adjust the output level by rotating the volume (fVR5) of S0070 so as to be set between 4.5 and 8V without any distortion of the waveform, as shown in Fig. 3-2.
- 4) If it is impossible to adjust the output level to 4.5V or more, reduce the gap distance between the screen plate and the photo sensor assembly to 0.8mm or less, as shown in Fig. 3-1.

Fig. 3-2 Output Waveform Adjustment on B-Sensor

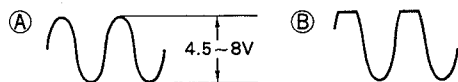

B. Duty ratio adjustment of output pulse waveform

- 1) Connect an oscilloscope across the TP3 of S0070 and GND, and set the selector switch to DC and the test ranges to 2V/div and 0.1sec/div.

- 2) Shift the tonearm by hand to the lead-out groove on the record disc, and slowly move the tonearm right and left in such a way that it takes about two seconds for the slit C of Fig. 3-1 to pass through between the LED and the phototransistor.
- 3) During this movement, adjust the duty ratio of the output pulse waveform by rotating the volume (fVR6) of S0070, as shown in Fig. 3-3.

Fig. 3-3

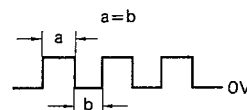

3-3. Lead-in Position Adjustment

- 1) Confirm that the screen plate is installed as shown in Figs. 3-1 (A), (B).
- 2) Turn the adjusting cam (See 7-1. Top View, 5. Exploded View) so as to lower the stylus to the middle of lead-in groove.

3-4. Speed Adjustment

- 1-a) Set the Pitch Control (hVR1) on control panel to center position.
- 2-a) Set the Speed Selector to 33 (r.p.m.)
- 2-b) Adjust eVR33 on the D.D. Motor Control Circuit Board (See 7-2. Bottom View on Page 12.) so as to standstill the strobo marking pattern.
- 3-a) Set the Speed Selector to 45 (r.p.m.)
- 3-b) Adjust eVR45 on the D.D. Motor Control Circuit Board (See 7-2. Bottom View on Page 12.) so as to standstill the strobo marking pattern.

3-5. Gap Adjustment between Plunger Solenoid and Plunger Plate

When the automatic mechanism assembly parts such as the tonearm assembly, slit plate, TA drum, or clutch plate are replaced with new ones, adjust a gap between the plunger solenoid and the plunger plate so as to be 0.2 to 0.3mm by pushing the plunger plate up as shown in Fig. 3-4.

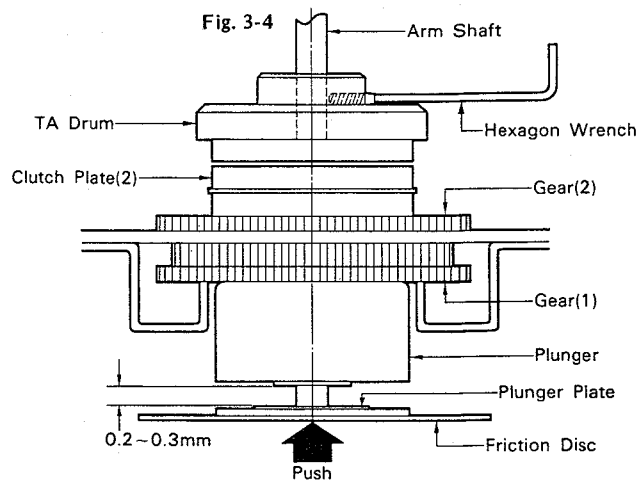

3-6. Adjustment of Automatic Music Selection Operation

Note: Before adjustment, make sure to mount the bottom cover.

● Required disc and measuring instruments

- 1) Tester (DC voltmeter)
Input impedance: 50kohm/V or more. (The higher, the better)
- 2) A vinyl chloride record disc without grooves or with wider lead-out spiral than usual.
- 3) A record disc with narrower lead-over grooves or moderately-wide lead-over grooves (less than 0.5mm) near a position 70 ~ 75mm away from the disc center. The record is desirable in which many musics about (seven music tracks) are recorded.
- 4) A rule with graduation marks starting from the edge.

A. Height adjustment of E and F sensor

(This adjustment is required when using a turntable sheet other than D55)

1. Objective

Accurate adjustment of the heights from the record disc surface to the E and F sensor is required so that both the sensors can perfectly perform the sensor operation.

2. Jig used

Use a rule explained above (4).

3. How to adjust (See Fig. 3-5)

- a) At the lifter up position, adjust the lifter angle by rotating the angle adjusting screw (B), so that the height deviation is less than 5mm at any position on the disc surface.
- b) Adjust the height to $7 \pm 0.5\text{mm}$ by rotating the arm lifter height adjusting screw (A).
- c) At the lifter-down position, check that the height is 3.5mm. (This height should be adjusted by using the cartridge mounting spacer.)

Fig. 3-5

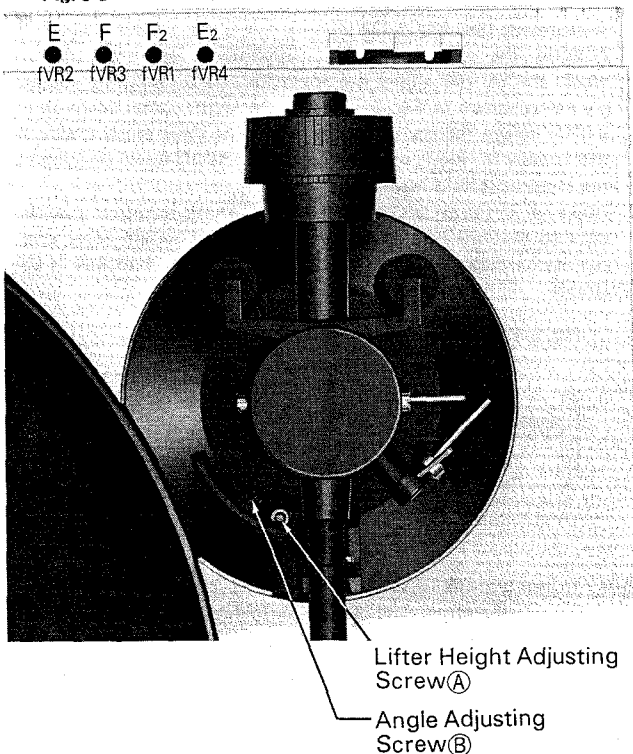

B. Sensitivity adjustment of E and F sensor

1. Setting

At the lifter-up position, in case of a record disc without grooves, stop the stylus at a position about 10cm away from the disc center. In case of a record disc having grooves, stop the stylus above the flat surface nears 10cm away from the disc center, as shown in Fig. 3-6.

Fig. 3-6

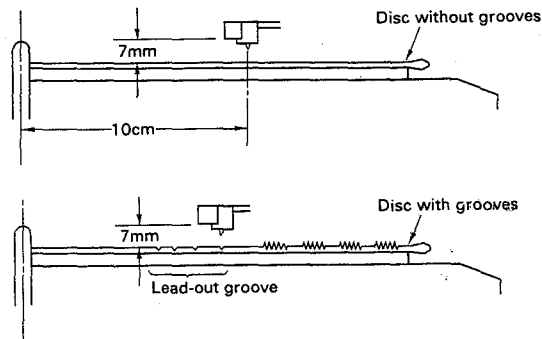

2. How to adjust (See Figs. 3-5 and 3-7)

- a) Connect the DC voltmeter across the test terminal E and G (ground) and then adjust the voltage to DC 5V by rotating the volume (fVR2) <E sensor adjustment>
- b) Connect the DC voltmeter across the test terminal F and G (ground) and then adjust the voltage to DC 5V by rotating the volume (fVR3) <F sensor adjustment>

Note: When adjusting both the sensors with the stylus stopped on a lead-over groove of an ordinary record disc, note that there is a difference in detection position between E sensor (leading sensor) and F sensor.

Fig. 3-7

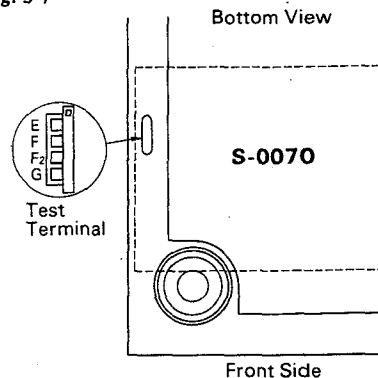

C. Level adjustment of F₂ signal (See Figs. 3-5 and 3-7)

1. Setting

Set the stylus in the same way as described under Section 2, and then move the lifter downward. (Check that the stylus stays on a lead-over groove.)

2. How to adjust

- a) Connect the DC voltmeter across test terminal F₂ and G (ground) and then adjust the voltage to DC 5V by rotating the volume (fVR1).

D. Lateral-direction adjustment of E and F sensor

1. Objective

Since there is a distance between the stylus tip and the F sensor as shown in Fig. 3-9, when the stylus is moved by hand shifting from the outward to the inward grooves, there arises a difference in position between the stylus and the F sensor, as shown in Fig. 3-8. Therefore, it is necessary to minimize this difference on the record disc on an average.

In this case, the optimum adjustment guideline is to adjust the stylus so as to be located at a position 0.8mm outward from the line which connects the F sensor and the stylus, as shown in Fig. 3-9

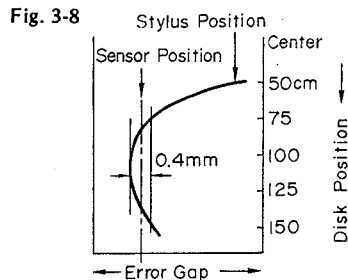
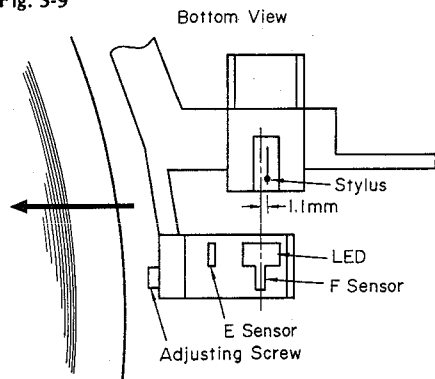

Fig. 3-9



2. Setting

- Mount a record disc explained under (3).
- Set the sensitivity selection switch to H when the lead-over groove is narrow, and to M when medium.

3. How to adjust (See Fig. 3-10)

- Push the music selection switch for the first music, and also the start/stop switch.
- Immediately after the stylus begins to come down, move the arm by hand so that the stylus may trace the disc groove beginning from a position 2mm or more outward from the lead-over groove about 70mm away from the disc center.
- Immediately after the above tracing, push the lifter switch twice. Be sure to push it with a time interval of 1sec or more, because of a ready operation to receive F₂ signal.
- Adjust the positions of E and F sensor by rotating the adjusting screws so that the muting switch can be turned ON (a click sound of plunger action is heard) when the stylus has passed through the lead-over groove. If the muting switch is turned ON earlier, rotate the adjusting screw counterclockwise to turn ON the switch later. (The thread pitch is 0.4mm.)

Fig. 3-10

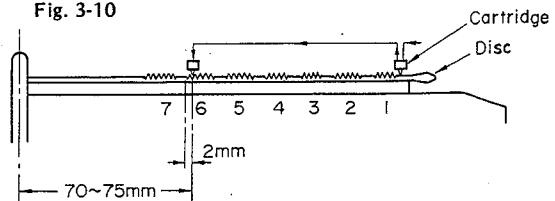

Note: The adjustment procedure described above has the following reasons:

- *1 The detection operation for the beginning of a music track can be omitted.
- *2 The stylus is made to shift from the outside to the center by hand so as to check that the stylus may come down onto the respective positions almost the same distance away from the respective lead-over grooves on the disc whenever the respective musics are selected.
- *3 Twice pushes of the lifter switch can release F₂S signal.

E. Delay adjustment of E₂ signal

(See the picture, Bottom View on Page 12.)

1. Objective

- Since the E sensor is located about 3mm before the stylus, it is necessary to electrically delay the signal from the E sensor.
- Since some of the mechanical parts are moved with accuracy of the order of milliseconds, it is necessary to adjust error due to mechanical operation.
- Since detection error occurs due to an eccentricity of the record disc, it is necessary to adjust the error.

2. Setting

- Use the record disc explained under (3), and select three music tracks having lead-over grooves, respectively, near positions 70mm, 100mm, and 130mm away from the disc center.

3. Adjustment (See Fig. 3-11)

- Perform the respective lead-in operations for three selected music tracks, and adjust the operations by rotating the volume (fVR4) as shown in Fig. 3-5 so that the stylus comes down on or a little before the lead-over grooves for the three music tracks. If the volume (fVR4) is rotated clockwise, the lift-down position of the stylus is shifted inward.

However, if the stylus comes down before the lead-over grooves, be sure that the muting switch is turned off within 20sec after the stylus moves down. The muting time from 3 to 6sec is desirable.

Fig. 3-11

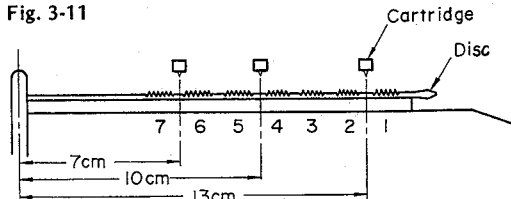

Note: In the lead-over grooves existing on a 70mm-or-less from the center, the misplacing of the arm in detection position occurs inevitably.

4. MAIN PARTS REPLACEMENT (See 5. Exploded View)

4-1. Replacement of Tonearm Ass'y (54)

- 1) Remove the bottom cover.
- 2) Loosen 3 screws (7) to remove the mechanism ass'y.
- 3) Loosen the installing screw to remove the TA drum (36).
- 4) Loosen the screw (37) to remove the screen plate (38).
- 5) Remove all lead wires of the tonearm soldered on the circuit board, S-0069.
- 6) The tonearm can be pulled out by loosening the fixing nut.

4-2. Replacement of Clutch Plate (1) (14)

- 1) Perform items 1), 2) "4-1. Replacement of Tonearm Ass'y" first.
- 2) Loosen the screw (12) to remove the clutch plate (2) (12).
- 3) The clutch plate (1) can be taken out.

4-3. Replacement of Plunger Solenoid Ass'y (16)

- 1) Perform items 1), 2) "4-1. Replacement of Tonearm Ass'y" first.
- 2) Loosen the screw (9) to remove the friction disk (10).
- 3) Remove the clutch plate (1), (2).
(See "4-2. Replacement of Clutch Plate (1)".)
- 4) The plunger solenoid ass'y can be taken out by loosening two screws (15).

4-4. Replacement of Gear (1) (21)

- 1) Perform items 1), 2) "Replacement of Tonearm Ass'y" first.
- 2) Remove the friction disk.
(See "4-3. Replacement of Plunger Solenoid Ass'y".)
- 3) Remove the clutch plate (1), (2).
(See "4-2. Replacement of Clutch Plate (1)".)
- 4) Remove the plunger solenoid ass'y.
(See "4-3. Replacement of Plunger Solenoid Ass'y".)
- 5) Remove E type washer (17).
- 6) Remove the gear (2) (18), the thrust washer (19), the dumping washer (20).
- 7) The gear (1) can be taken out.

4-5. Replacement of Gear (3) (22)

- 1) Perform items 1), 2) "4-1. Replacement of Tonearm Ass'y" first.
- 2) Remove the plunger solenoid ass'y.
(See "4-3. Replacement of Plunger Solenoid Ass'y".)
- 3) Remove the clutch plate (1), (2).
(See "4-3. Replacement of Clutch Plate (1)".)
- 4) Remove the gear (1).
(See "4-4. Replacement of Gear (1)".)
- 5) Remove E type washer (35).
- 6) The gear (3) can be taken out by removing the friction pulley (25), the spring (23).

4-6. Replacement of Lifter Cam Ass'y (32)

- 1) Perform items 1), 2) "Replacement of Tonearm Ass'y" first.
- 2) Remove E type washer (29).
- 3) Remove the lifter guide (30).
- 4) Remove E type washer (31).
- 5) The lifter cam ass'y can be taken out.

4-7. Note on Parts Replacement

- 1) Refer to Fig. 3-1 (A), (B), and 3-4, when installing screen plate and TA drum.
- 2) When installing the clutch plate (1), fit notch face of the clutch plate (1) to the gear (2).
- 3) When replacing friction pulleys, insert two pulleys to gear (3) to face their smoothed surface each other.
- 4) When replacing photo-transistors on the photo-sensor ass'y, attach the photo-transistor so as to meet the center of photo-transistor to the slit of photo-sensor ass'y.
- 5) When installing the plunger solenoid ass'y and the clutch plate (2), adjust the gap of the plunger solenoid so as to be 1.1 mm. (Refer to Fig. 3-4)

* Before replacing a part of the mechanism ass'y, clean it up by the alcohol, especially in friction face.

5. EXPLODED VIEW OF MECHANISM Ass'y & PARTS LIST

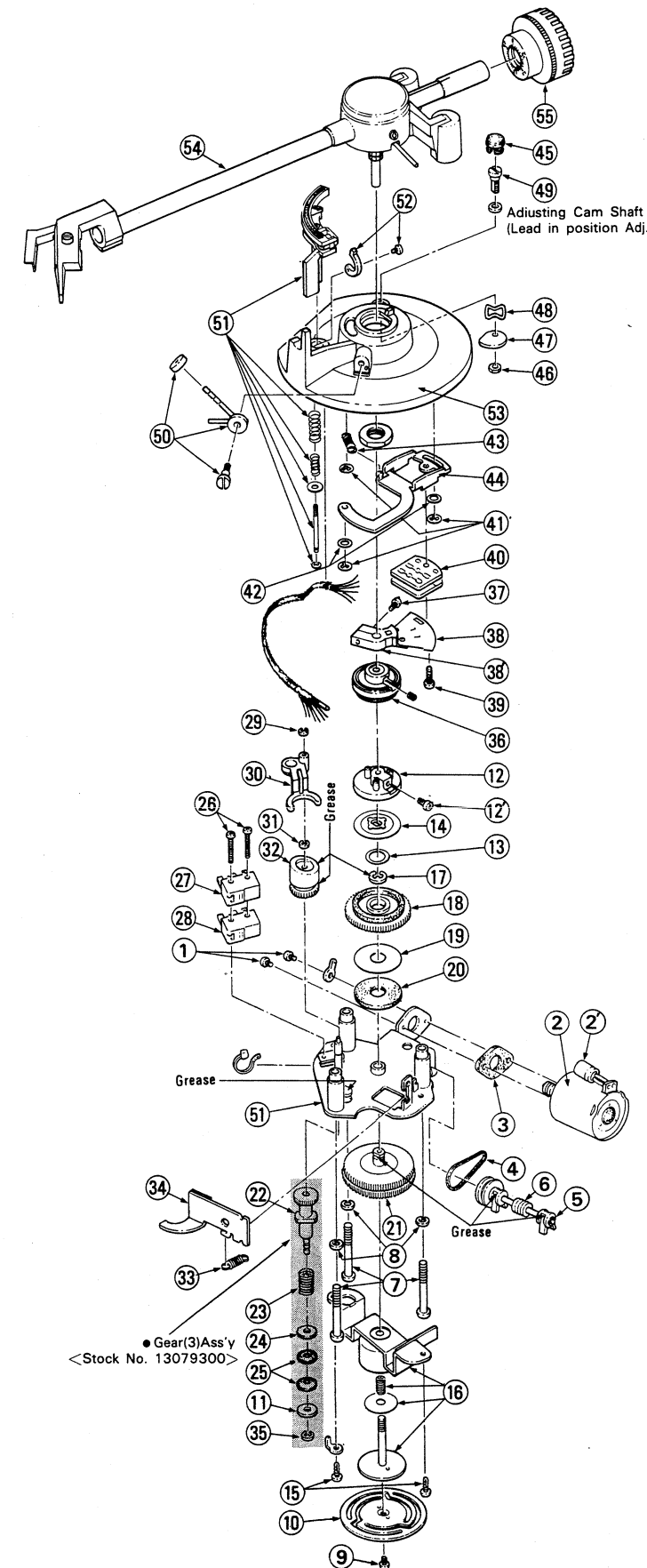

Parts List

Parts No.	Stock No.	Description
1	00436500	P Type Screw, M2 x 4
2	07207700	Micro Motor Ass'y
2'	00304000	47μF 10V E.B.
3	55029810	Rubber Cushion
4	60322310	Drive Belt
5	00488900	E Type Washer, D1.5
6	13011110	Worm Gear Ass'y (Worm Gear, Shaft, E Type Washer D1.5)
7	13073100	Tapping Screw, M4 x 35
8	00469800	S Type Washer, M4 x 14
9	00436500	P Type Screw, M2 x 4
10	61423710	Friction Disc
11	13033510	Washer, Friction Pulley
12	13034010	Clutch Plate (2)
12'	13044700	Tapping Screw, M3 x 6
13	13021800	P Type Washer, M7 x 11
14	64220700	Clutch Plate (1)
15	00454500	PT Type Screw Type 2, 3 x 8
16	07266100	Plunger Solenoid Ass'y
17	00489400	E Type Washer, D5.0
18	60020710	Gear (2)
19	51831500	Thrust Washer
20	51831610	Damping Washer (1)
21	13033800	Gear (1)
22	13033910	Gear (3)
23	13033600	Spring, Friction Pulley
24	00466500	P Type Washer, M3 x 8
25	13033710	Friction Pulley
26	08320400	P Type Screw, M2 x 16
27	11602700	Micro Switch
28	11602700	Micro Switch
29	00488900	E Type Washer, D1.5
30	13034610	Lifter Guide
31	00489000	E Type Washer, D2.0
32	13064500	Lifter Cam Ass'y
33	13045200	Tension Spring (3)
34	64020310	Brake Shoe
	55221000	Brake Felt
35	00489000	E Type Washer, D2.0
36	65121930	TA Drum Ass'y
37	07104500	PT Type Screw, 3 x 10
38	13040500	Screen Plate
38'	13038710	Screen Plate Base
	13069400	Tapping Screw, M2 x 5
39	13057400	P Type Screw, M2.5 x 8
40	07217900	Photo Sensor Ass'y
41	51831800	CS Ring, M2.4
42	13052600	Thrust Washer, 3 x 0.5
43	69034200	Tension Spring (2)
44	13039400	Sensor Mounting Arm
45	50624800	Lid
46	00463600	H Type Nut, M3 x 2.4
47	60125600	Adjusting Cam (2)
48	51832100	Wave Washer, M4
49	13040700	Adjusting Cam Shaft
50	13074200	IFC Ass'y
51	13074800	Lifter Ass'y
52	13074400	Armrest Hook Ass'y
53	13074300	Arm Base Ass'y
54	13074700	Tone Arm Ass'y
55	13074100	Main Weight Ass'y

Abbreviations				
1. Pan Head Tapping Screw . . . PT Type	5. Pan Head SEMS B Screw . . . PSB Type	9. Flat Counter Sunk Wood Screw . . . FC Type	13. Binding Head SEMS B Screw . . . BSB Type	17. Toothed Lock Washer (External) . . . TLE Washer
2. Washer Head Tapping Screw . . . WT Type	6. Binding Head SEMS F Screw . . . BSF Type	10. Round Head Wood Screw . . . RH Type	14. Spring Washer . . . S Type	18. Wave Washer
3. Pan Head Screw . . . P Type	7. Binding Head Screw . . . B Type	11. Hex. Socket Setscrew . . . SC Type	15. Plain Washer . . . P Type	19. Hexagon Nut H Type Nut
4. Pan Head SEMS A Screw . . . PSA Type	8. Flat Counter Sunk Head Screw . . . F Type	12. Slot Type Setscrew . . . SS Type	16. Retaining Ring (E Washer) . . . E Type	

6. PARTS LOCATION & PARTS LIST

Since some of capacitors and resistors are omitted from parts lists in this Service Manual, refer to the Common Parts List for capacitors & resistors, which was appended previously to Sansui Manual.

6-1. S-0070 T.A. Control Circuit Board (Stock No. 13057201)

Component Side

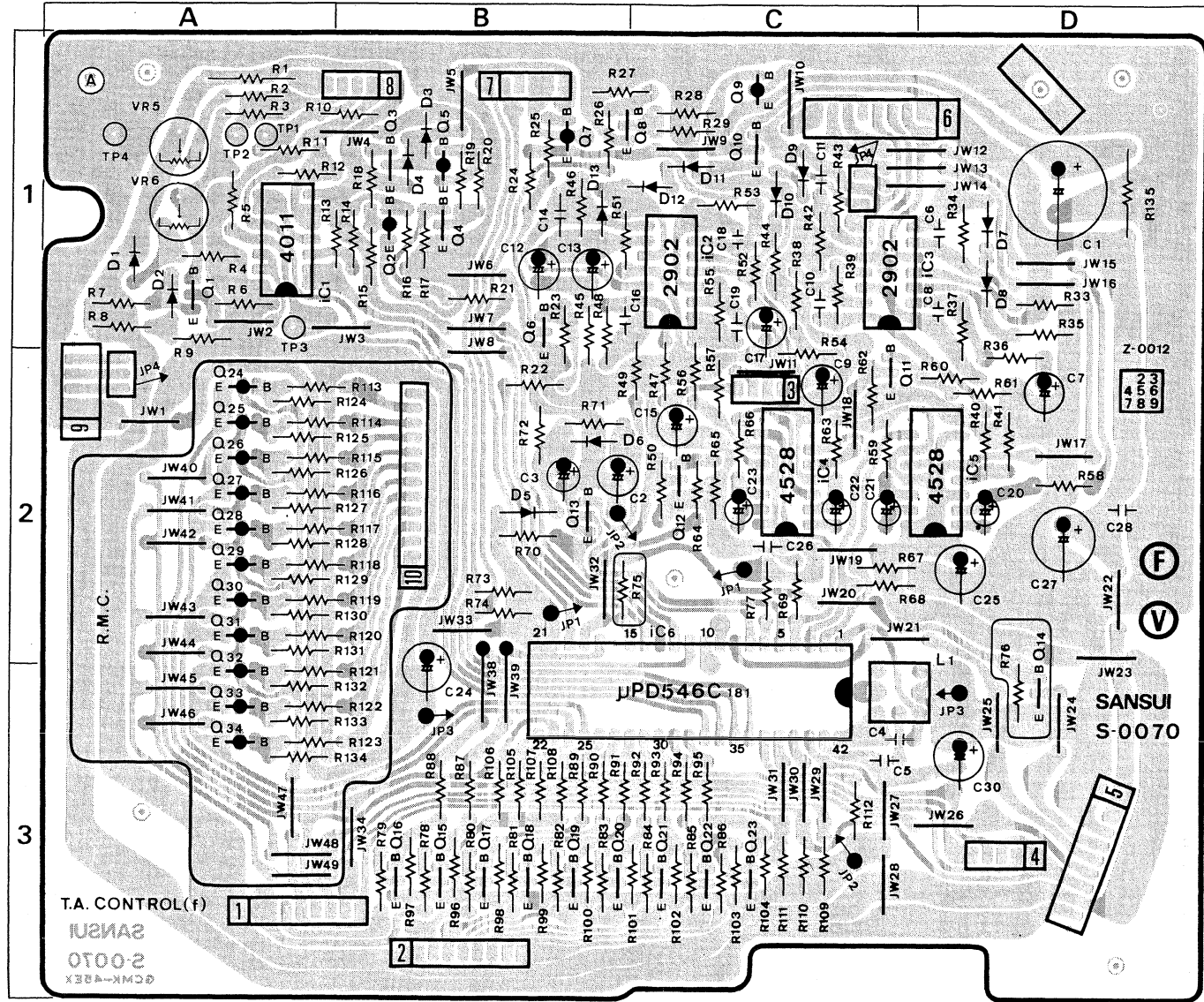

• Abbreviations

- | | |
|--|--|
| C.R. Carbon Resistor | E.L. Low Leak Electrolytic Capacitor |
| S.R. Solid Resistor | E.B. Bi-Polar Electrolytic Capacitor |
| Ce.R. Cement Resistor | E.BL. Low Leak Bi-Polar Electrolytic Capacitor |
| M.R. Metal Film Resistor | Capacitor |
| F.R. Fusing Resistor | Ta.C. Tantalum Capacitor |
| N.I.R. Non-Inflammable Resistor | F.C. Film Capacitor |
| C.C. Ceramic Capacitor | M.P. Metallized Paper Capacitor |
| C.T. Ceramic Capacitor, Temperature Compensation | P.C. Polystyrene Capacitor |
| E.C. Electrolytic Capacitor | G.C. Gimmic Capacitor |

Parts List <S-0070>

Parts No.	Stock No.	Description
• Transistor		
fQ1	07194800	2SC1815 Y
	03059501	2SC945 Q
fQ2	07194700, 1	2SA1015 Y, GR
	07197001, 2	2SA733A Q, P
	07299601, 2	2SA1115 E, F
fQ3	07254900, 1	2SC1741 Q, R
	07206900, 1	2SC2001 M, L
fQ4	07194800, 1	2SC1815 Y, GR
	03059501 ~ 3	2SC945 Q, P, K
	07299701, 2	2SC2603 E, F
fQ5	07254800, 1	2SA854 Q, R
	07206800, 1	2SA952 M, L
fQ6	07194800, 1	2SC1815 Y, GR
	03059501 ~ 3	2SC945 Q, P, K
	07299701, 2	2SC2603 E, F
fQ7	03012200 ~ 2	2SA934 P, Q, R
	07260000 ~ 2	2SA935 P, Q, R
	07270700 ~ 2	2SA881 P, Q, R
fQ8	07194800, 1	2SC1815 Y, G
	03059501 ~ 3	2SC945 Q, P, K
	07299701, 2	2SC2603 E, F
fQ9	03012200 ~ 2	2SA934 P, Q, R
	07260000 ~ 2	2SA935 P, Q, R
	07270700 ~ 2	2SA881 P, Q
fQ10	07194800, 1	2SC1815 Y, GR
	03059501 ~ 3	2SC945 Q, P, K
	07299701, 2	2SC2603 E, F
fQ11	07194800, 1	2SC1815 Y, GR
	03059501 ~ 3	2SC945 Q, P, K
	07299701, 2	2SC2603 E, F
fQ12	07194800, 1	2SC1815 Y, GR
	03059501 ~ 3	2SC945 Q, P, K
	07299701, 2	2SC2603 E, F
fQ13	07194800, 1	2SC1815 Y, GR
	03059501 ~ 3	2SC945 Q, P, K
	07299701, 2	2SC2603 E, F
fQ14 (V-Servo Motor Only)		
	03059302	2SC1211E
	07206901	2SC2001 L
	03069101, 2	2SC2060 Q, R
	07270601, 2	2SC2673 Q, R
	03085202	2SD438 F
	03085901, 2	2SD471 L, K
fQ14 (V-Servo Motor Only)		
	07194800, 1	2SC1815 Y, GR
	03059501 ~ 3	2SC945 Q, P, K
fQ15	07194800, 1	2SC1815 Y, GR
	03059501 ~ 3	2SC945 Q, P, K
	07299701, 2	2SC2603 E, F
fQ16	07194800, 1	2SC1815 Y, GR
	03059501 ~ 3	2SC945 Q, P, K
	07299701, 2	2SC2603 E, F
fQ17	07194800, 1	2SC1815 Y, GR
	03059501 ~ 3	2SC945 Q, P, K
	07299701, 2	2SC2603 E, F
fQ18	07194800, 1	2SC1815 Y, GR
	03059501 ~ 3	2SC945 Q, P, K
	07299701, 2	2SC2603 E, F
fQ19	07194800, 1	2SC1815 Y, GR
	03039501 ~ 3	2SC945 Q, P, K
	07299701, 2	2SC2603 E, F
fQ20	07194800, 1	2SC1815 Y, GR
	03059501 ~ 3	2SC945 Q, P, K
	07299701, 2	2SC2603 E, F
fQ21	07194800, 1	2SC1815 Y, GR
	03059501 ~ 3	2SC945 Q, P, K
	07299701, 2	2SC2603 E, F
fQ22	07194800, 1	2SC1815 Y, GR
	03059501 ~ 3	2SC945 Q, P, K
	07299701, 2	2SC2603 E, F
fQ23	07194800, 1	2SC1815 Y, GR
	03059501	2SC945 Q, P, K
	07299701, 2	2SC2603 E, F
fQ24	07194700, 1	2SA1015 Y, GR
	07197001, 2	2SA733A Q, P
	07299601, 2	2SA1115 E, F
fQ25	07194700, 1	2SA1015 Y, GR
	07197001, 2	2SA733A Q, P
	07299601, 2	2SA1115 E, F

Parts No.	Stock No.	Description
fQ26	07194700, 1	2SA1015 Y, GR
	07197001, 2	2SA733A Q, P
	07299601, 2	2SA1115 E, F
fQ27	07194700, 1	2SA1015 Y, GR
	07197001, 2	2SA733A Q, P
	07299601, 2	2SA1115 E, F
fQ28	07194700, 1	2SA1015 Y, GR
	07197001, 2	2SA733A Q, P
	07299601, 2	2SA1115 E, F
fQ29	07194700, 1	2SA1015 Y, GR
	07197001, 2	2SA733A Q, P
	07299601, 2	2SA1115 E, F
fQ30	07194700, 1	2SA1015 Y, GR
	07197001, 2	2SA733A Q, P
	07299601, 2	2SA1115 E, F
fQ31	07194700, 1	2SA1015 Y, GR
	07197001, 2	2SA733A Q, P
	07299601, 2	2SA1115 E, F
fQ32	07194700, 1	2SA1015 Y, GR
	07197001, 2	2SA733A Q, P
	07299601, 2	2SA1115 E, F
fQ33	07194700, 1	2SA1015 Y, GR
	07197001, 2	2SA733A Q, P
	07299601, 2	2SA1115 E, F
fQ34	07194700, 1	2SA1015 Y, GR
	07197001, 2	2SA733A Q, P
	07299601, 2	2SA1115 E, F
• IC		
fIC1	03604100	TC4011P
	07207200	MB84011BM
fIC2	07205200	NJM2902N
	07258300	MB3614M
fIC3	07205200	NJM2902N
	07258300	MB3614M
fIC4	03612900	TC4528BP
fIC5	03612900	TC4528BP
fIC6	07260700	μPD546C-181
• Diode		
fd1	03111600	1S2473D
fd2	03401200	VD-1212 (Varistor)
	46079300	MV-13 (Varistor)
fd3	03111600	1S2473D
fd4	03111600	1S2473D
fd5	03103400	10D-1
fd6	03111600	1S2473D
fd7	03111600	1S2473D
fd8	03111600	1S2473D
fd9	03111600	1S2473D
fd10	03111600	1S2473D
fd11	03111600	1S2473D
fd12	03111600	1S2473D
fd13	03111600	1S2473D
fR135	00186800	150Ω 2W N.I.R.
fC12	00292700	10μF 25 V E.C.
fC13	00292700	10μF 25 V E.C.
fL1	42306100	OSC Coil
fVR5	10351100	Semi Variable Resistor 4.7 kΩ (B), (B Sensor Sensitivity ADJ.)
fVR6	10351500	Semi Variable Resistor 22 kΩ (B), (Record End Sensitivity ADJ.)

6-2. S-0067 Power Supply Circuit Board (Stock No. 13056901)

Component Side

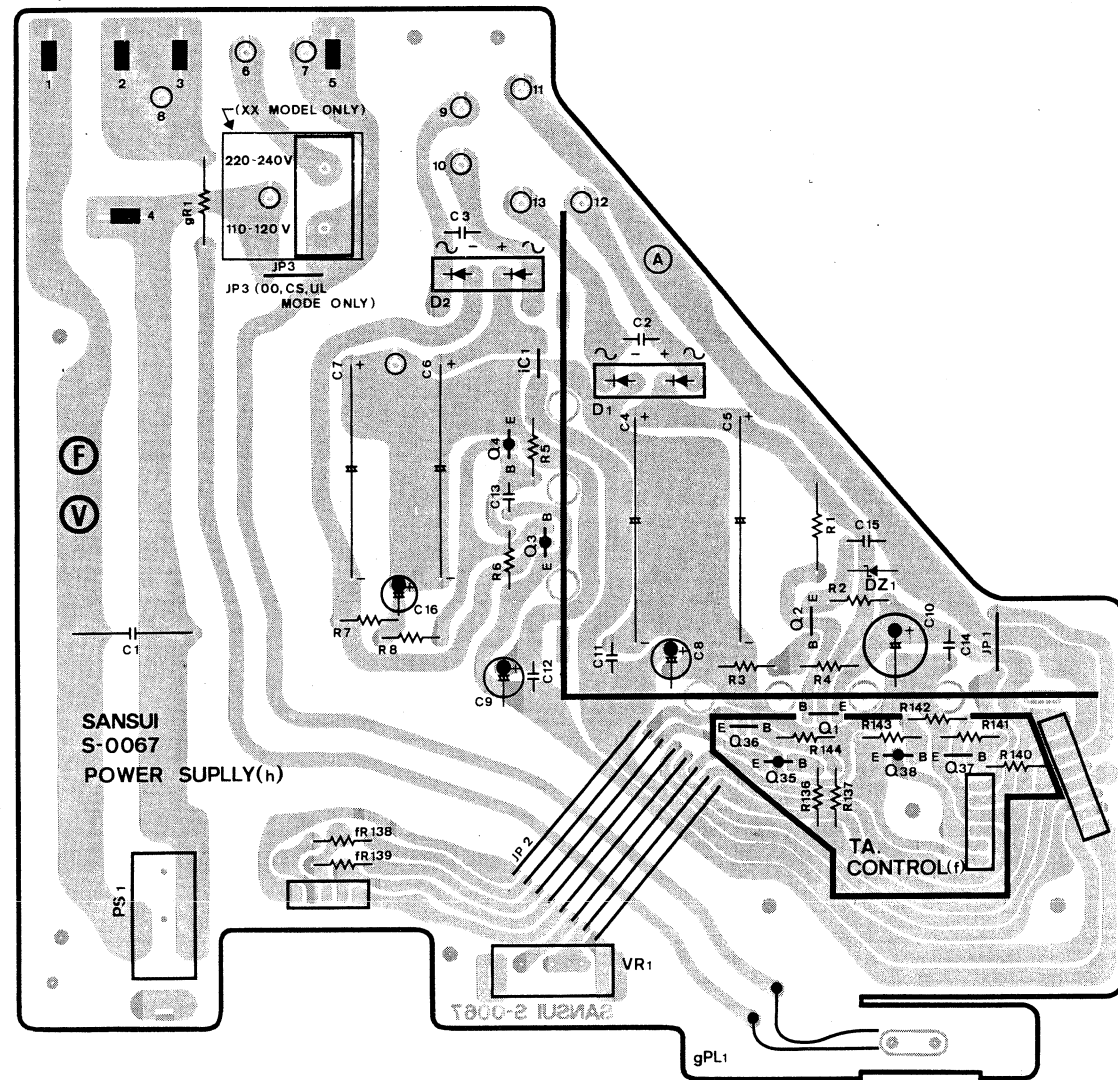

Parts List

Parts No.	Stock No.	Description	Parts No.	Stock No.	Description
•Transistor			•IC		
fQ35	07194700, 1	2SA1015 Y, GR	hIC1	07183500	μPC78M05H
	07197001, 2	2SA733A Q, P		03609200	FS7805M
	07299601, 2	2SA1115 E, F	hD1	03117000	RB-152
fQ36	07194800, 1	2SC1815 Y, GR	hD2	03117000	RB-152
	03059501 ~ 3	2SC945 Q, P, K	•Zener Diode		
	07299701, 2	2SC2603 E, F	hDZ1	03166300	RD5.1E
fQ37	07194800, 1	2SC1815 Y, GR	hR1	00184400	680Ω 1W N.I.R.
	03059501 ~ 3	2SC945 Q, P, K	hC1	00386000	1000 pF 150 V C.C.
	07299701, 2	2SC2603 E, F	hC2	00407800	0.047μF 100 V M.C.
fQ38	07194700, 1	2SA1015 Y, GR	hC3	00407800	0.047μF 100 V M.C.
	07197001, 2	2SA733A Q, P	hC4	00283400	470μF 50 V E.C.
	07299601, 2	2SA1115 E, F	hC5	00283400	470μF 50 V E.C.
gR1	00179900	12 kΩ 1W N.I.R.	hC6	00281800	470μF 25 V E.C.
gNL1	07253900	Neon Lamp	hC7	00281800	470μF 25 V E.C.
•Transistor			hVR1	46036000	Variable Resistor 50 kΩ (B) (FG-Servo Motor)
hQ1	03070400	2SC1983		07247300	Variable Resistor 2 kΩ (B) (V-Servo Motor)
hQ2	03068500, 1	2SC1844 F, E	hS1	07270400	Push Switch, POWER
	03062801, 2	2SC1735 D, E			
	03059301	2SC1211 D			
hQ3	03034401, 2	2SB527 D, E			
hQ4	07194700, 1	2SA1015 Y, GR			
	07197001, 2	2SA733A Q, P			
	07299601, 2	2SA1115 E, F			

• Note: The circuit boards, S-0069, S-0071, S-0060 & S-0068 are not supplied as the assembled. However, individual parts on the circuit board are provided by orders.

6-3. S-0069 E/E₂, F/F₂ Sensor Adjusting Circuit Board

Component Side

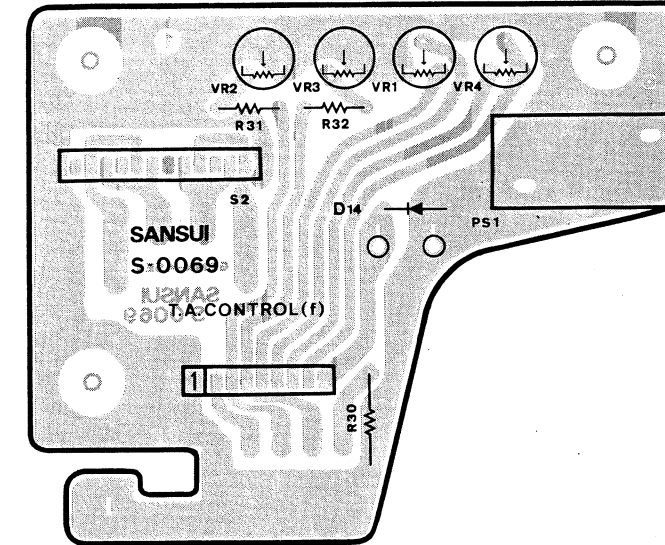

Parts List

Parts No.	Stock No.	Description
•Diode		
fD14	03103400	10D-1
fR30	00184400	680Ω 1W N.I.R.
fPS1	07259800	Plunger Solenoid
fVR1	10351300	Semi Variable Resistor 10 kΩ (B), (F ₂ Sensor Sensitivity ADJ.)
fVR2	10352100	Semi Variable Resistor 220 kΩ (B), (E Sensor Sensitivity ADJ.)
fVR3	10352100	Semi Variable Resistor 220 kΩ (B), (F Sensor Sensitivity ADJ.)
fVR4	10352300	Semi Variable Resistor 470 kΩ (B), (E ₂ Sensor Sensitivity ADJ.)
fs2	07207800	Slide Switch

6-4. S-0071 Control Switch & Indicator Circuit Board

Component Side

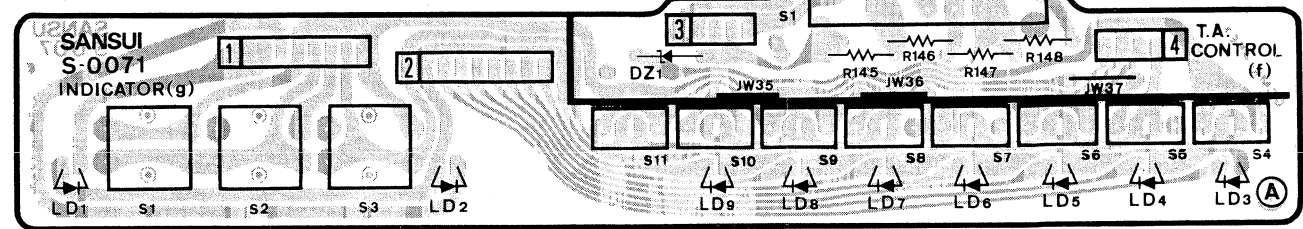

Parts List

Parts No.	Stock No.	Description	Parts No.	Stock No.	Description
fs1	07257500	Slide Switch, sensor sensitivity	gS1	11907000	Push Switch, START/STOP
gLD1	07246200	Light Emitting Diode SEL1710K	gS2	11907000	Push Switch, UP/DOWN
gLD2	03192500	Light Emitting Diode PR5534S	gS3	11907000	Push Switch, REPEAT
gLD3	07246200	Light Emitting Diode SEL1710K	gS4 ~ 10	11320900	Push Switch, music selection
gLD4	07246200	Light Emitting Diode SEL1710K	gS11	11320900	Push Switch, CLEAR
gLD5	07246200	Light Emitting Diode SEL1710K	•Zener Diode		
gLD6	07246200	Light Emitting Diode SEL1710K	fDZ1	03159000	EQA01-10S
gLD7	07246200	Light Emitting Diode SEL1710K			
gLD8	07246200	Light Emitting Diode SEL1710K			
gLD9	07246200	Light Emitting Diode SEL1710K			

6-5. S-0060 E/F Sensor Circuit Board

Parts List

Parts No.	Stock No.	Description
fLD1	07205900	Light Emitting Diode LD261
•Transistor		
fQ39	07205800	Photo Transistor BPX81
fQ40	07205800	Photo Transistor BPX81

6-6. S-0068 33/45 r.p.m. Selector Switch & Indicator Circuit Board

Parts List

Parts No.	Stock No.	Description
gLD10	07220700	Light Emitting Diode (Red)
gLD11	07220700	Light Emitting Diode (Red)
gS12	11907000	Push Switch

7. OTHER PARTS

7-1. Top View

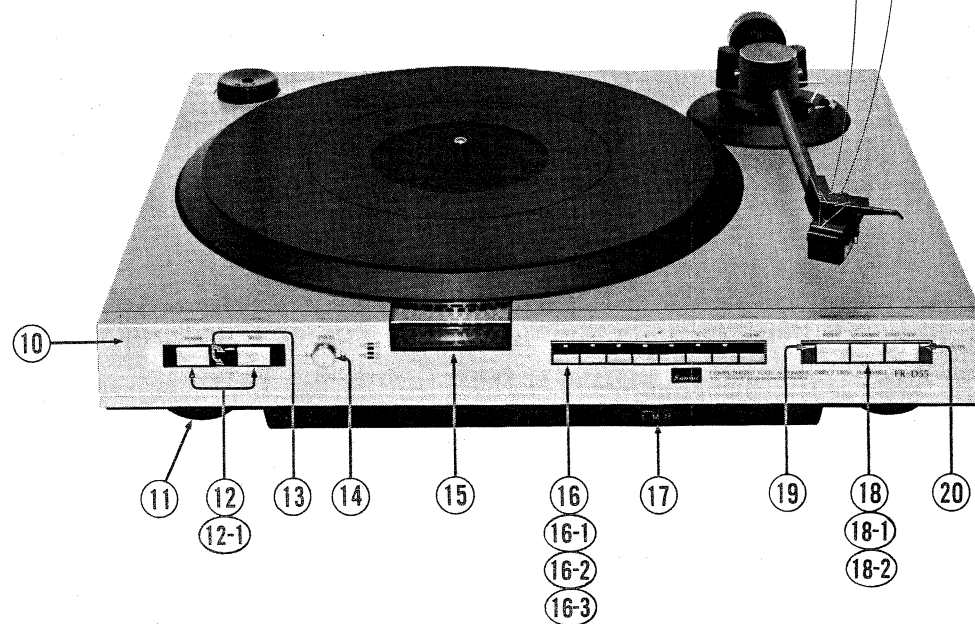
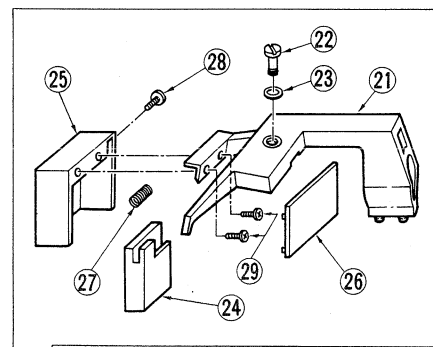
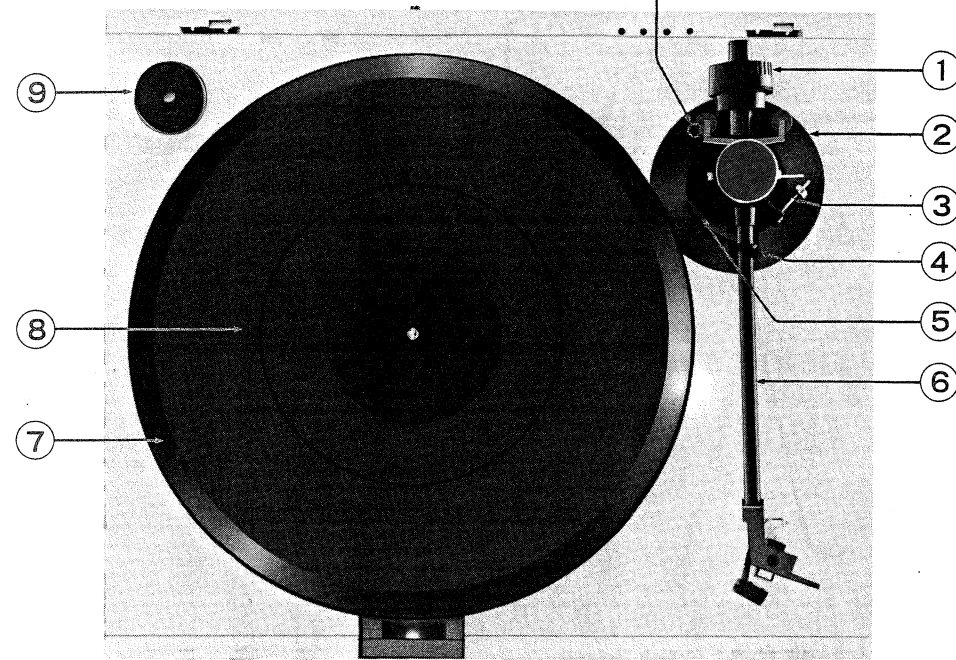
Adjusting Cam
(Lead-in Position Adj.)

7-2. Bottom View

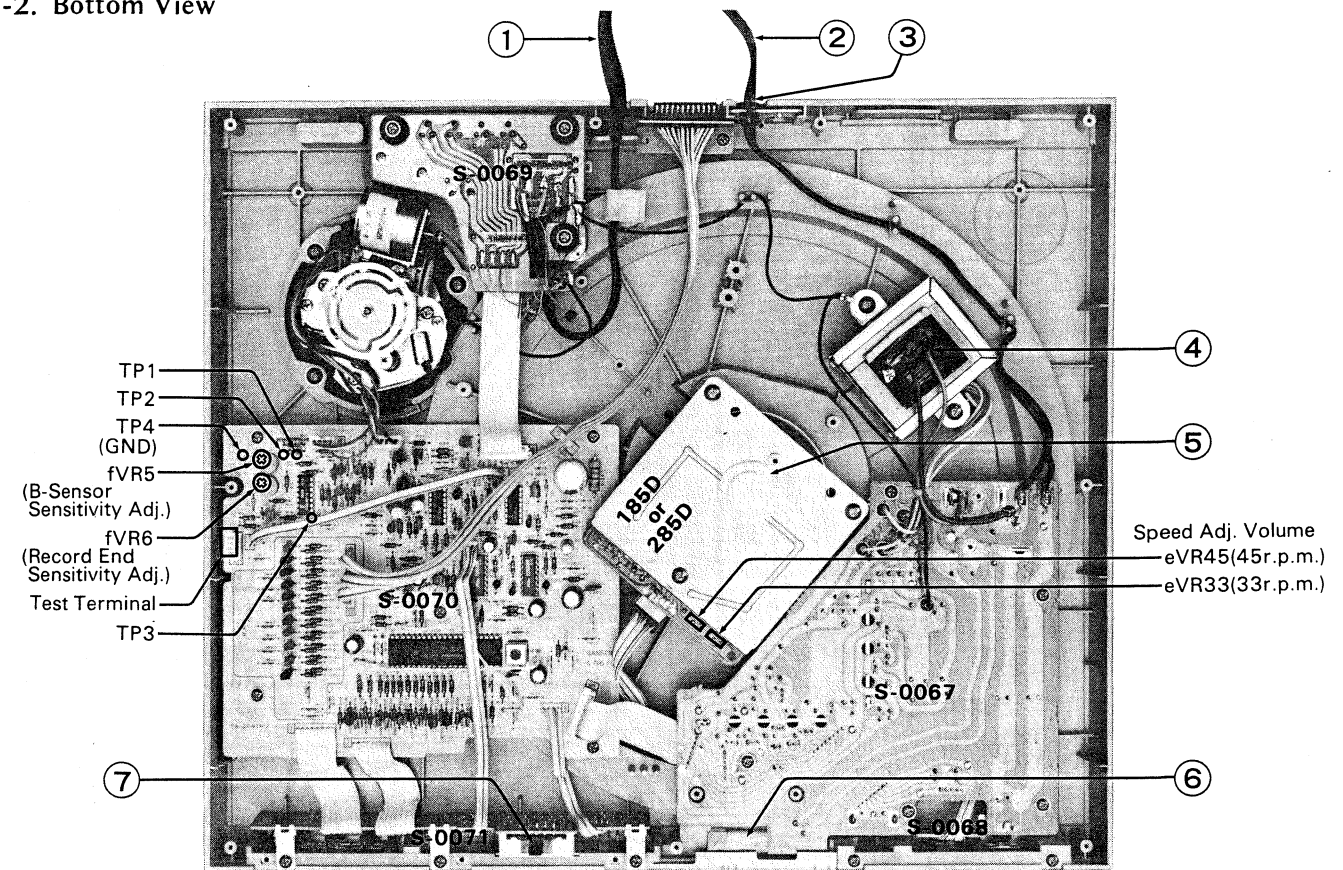

Parts List <Top View>

Parts No.	Stock No.	Description
1	13074100	Main Weight Ass'y
2	13074300	Arm Base Ass'y
3	13074200	IFC Ass'y
4	13074400	Arm Rest Hook Ass'y
5	13074800	Lifter Ass'y
6	13074700	Tone Arm Ass'y
7	13040110	Platter
8	13036600	Rubber Mat
9	13012300	EP Adaptor
10	13036300	Front Panel
11	13034100	Insulator
12	13037000	Push Knob, POWER, SPEED
12-1	13036900	Push Knob Guide
13	07220700	Light Emitting Diode (Red)
14	13037100	Knob, PITCH
15	13037700	Strobo Cover
16	13034300	Push Knob Ass'y, CLEAR, music selection
16-1	13034200	Indicator Plate
16-2	13034400	Push Knob
16-3	13034500	Push Knob Guide
17	07207800	Slide Switch, SENSOR sensitivity selection
18	13037300	Push Knob Ass'y, REPEAT, UP/DOWN, START/STOP
18-1	13037000	Push Knob
18-2	13036800	Push Knob Guide (C)
19	13037800	Indicator Plate (Red)

Parts No.	Stock No.	Description
20	13039600	Indicator Plate (Green), COMPUTER
21	13074900	Head Shell Ass'y
22	13040800	Mounting Screw
23	51823300	Thrust Washer, 4 x 0.25
24	13028801	E/F Sensor Ass'y, (S-0060 Sensor Ass'y, Circuit Board, Sensor Case, Sensor Mounting Plate)
25	13023220	Sensor Cover
26	13023520	Sensor Bottom Plate
27	13023600	Sensor Spring
28	13031000	Screw M2 x 8, adjusting screw
29	13030900	Screw M1.4 x 2, mounting screw

Parts List <Bottom View>

Parts No.	Stock No.	Description
1	38103610	P.U. Output Cord
2	38004700	Power Supply Cord
3	39106000	Strain Relief
4	15002601	Power Transformer
5	{ 13051000 13065700	{ 185D V - Servo DD Motor 285D FG - Servo DD Motor } with control circuit board
6	07253900	Neon Lamp, strobo
7	07207800	Slide Switch

*Note:

When ordering the motor unit, the type No. of the DD MOTOR (185D or 285D) must be confirmed because either one is used.

8. SCHEMATIC DIAGRAM 8-1. With 185D V-Servo DD Motor

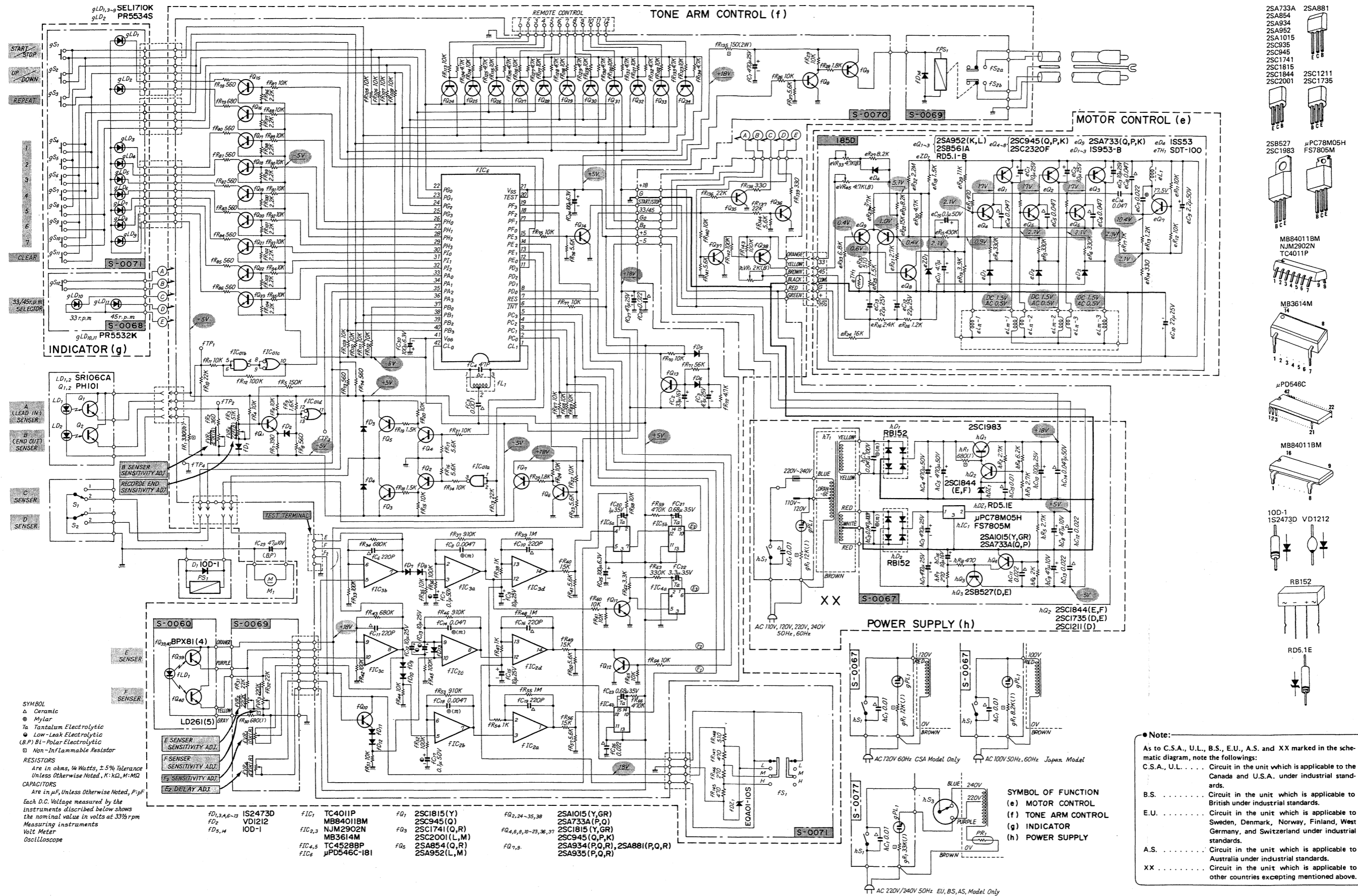

1
2
3
4
5

8-2. With 285D FG-Servo DD Motor

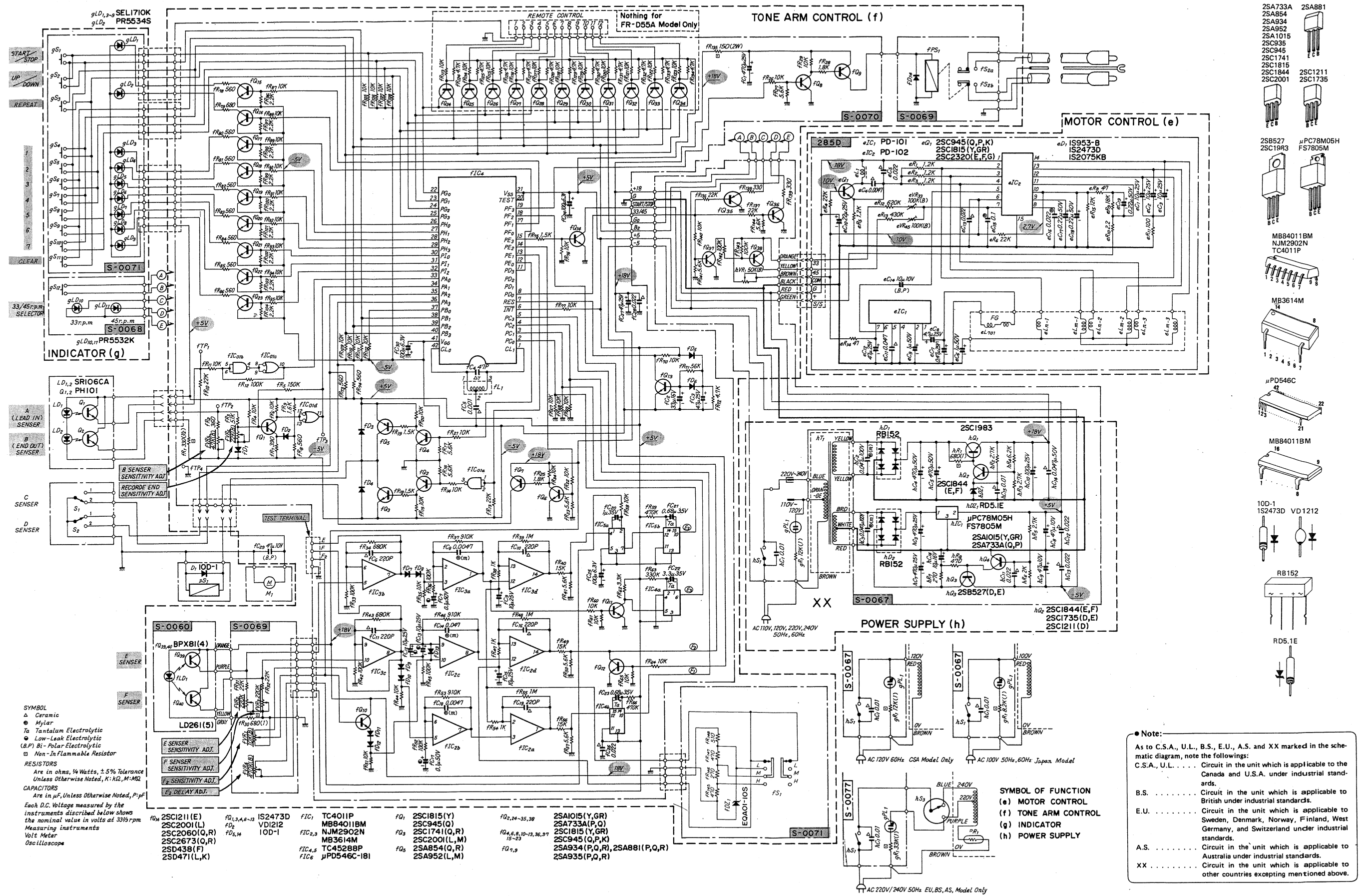

Note:
 As to C.S.A., U.L., B.S., E.U., A.S. and XX marked in the schematic diagram, note the followings:
 C.S.A., U.L. Circuit in the unit which is applicable to the Canada and U.S.A. under industrial standards.
 B.S. Circuit in the unit which is applicable to British under industrial standards.
 E.U. Circuit in the unit which is applicable to Sweden, Denmark, Norway, Finland, West Germany, and Switzerland under industrial standards.
 A.S. Circuit in the unit which is applicable to Australia under industrial standards.
 XX Circuit in the unit which is applicable to other countries excepting mentioned above.

9. PACKING LIST

Parts No.	Stock No.	Description
1	13040300	Protector Board, upper
2	70122210	Dust Cover Ass'y
3	91122500	Polyethylene Bag, dust cover
4	13035800	Protector Board, platter
5	13036600	Rubber Mat
6	13040110	Turntable Platter
7	91166000	Polyethylene Bag, turntable
8	91122710	Polyethylene Bag, turntable unit
9	13057500	Styrofoam Packing, front
10	13057600	Styrofoam Packing, rear
11	13040200	Accessory Box
12	13049500	Carton Case

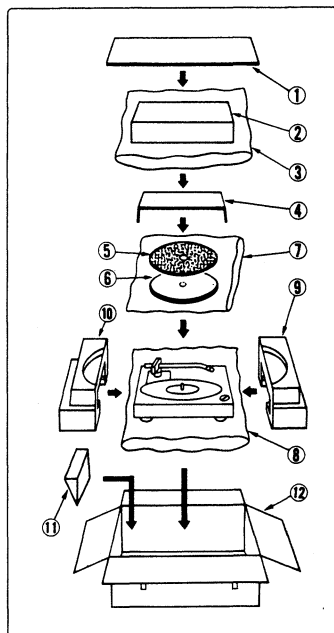

10. ACCESSORY LIST

Parts No.	Stock No.	Description
1	52432210	Cartridge Mounting Gauge (1)
2	13065600	Cartridge Mounting Gauge (2)
3	13024510	Cartridge Spacer Ass'y
	43103700	Cartridge Ass'y, SC-50
	49402300	Stylus, SN-50
*	13010800	Cartridge Ass'y, SV-101
	13010900	Stylus, SN-101
	13073600	Cartridge Ass'y, SV-202
	13073800	Stylus, SN-202
	13031600	Cartridge Screw Ass'y
	94220300	Screw Driver
	13012300	EP Adaptor
	13044600	Auto Hinge, dust cover
	07643600	Operating Instruction

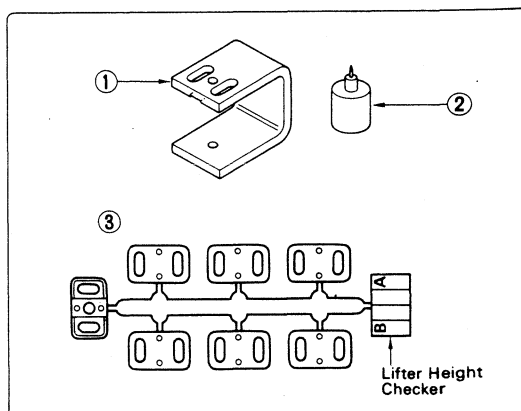

*Note:

There are two types of units in FR-D55.

1) The unit with a cartridge (SC-50, SV-101 or SV-202).

2) The unit without a cartridge.

The mark (E) is stamped on the side of carton case.

- In particular area, either type of these unit is sold.