

The Armstrong Series 600

ARMSTRONG SERIES 600

- | | |
|-----|----------------|
| 621 | AMPLIFIER |
| 623 | AM-FM TUNER |
| 624 | FM TUNER |
| 625 | FM RECEIVER |
| 626 | AM-FM RECEIVER |

C O N T E N T S

	PAGE
CIRCUIT DESCRIPTIONS	
FM TUNER	3
AM TUNER	4
PRE-AMPLIFIER AND CONTROL UNIT	4
POWER AMPLIFIER	5
POWER SUPPLY	6
TEST AND ALIGNMENT PROCEDURES	
EQUIPMENT REQUIRED	7
SETTING UP	7
AUDIO TEST	8
FM RF TEST	12
AM RF TEST	16
QUALITY CONTROL PROCEDURES	
AUDIO	18
FM	20
AM	22
CIRCUIT DIAGRAM	INSERT 1
MODULE AND COMPONENT LAYOUT	INSERT 1
DRIVE CORD REPLACEMENT	INSERT 1
USER'S INSTRUCTIONS	INSERT 2

CIRCUIT DESCRIPTION

FM TUNER

Aerial inputs to the tuner are both 70/80 ohms co-axial and 250/300 ohms balanced. The 250/300 ohms input is fed via a matched balun transformer so that aerial signals are passed on with minimal losses to the tuned bandpass input filter designed to reject unwanted signals before the RF amplifier.

The dual gate FET RF amplifier feeds via a further tuned filter to the mixer (frequency changer) stage. Automatic gain control (AGC) is applied to the RF amplifier so that it can handle a wide range of signal levels without overload or cross modulation.

The mixer is also a dual gate FET. The signal is applied to gate 1 and the oscillator to gate 2, the aim of this design of mixer being to minimise the spurious responses. Varicap diodes are used and the applied voltage for tuning is from a potentiometer for manual tuning and from a series of six 20 - turn potentiometers which are switched for pre-set tuning.

The intermediate frequency output from the mixer is passed via a bandpass filter to an amplifier stage using an epitaxial planar transistor. After amplification the signal goes to a ceramic filter and then to a further epitaxial planar transistor. AGC voltage for the RF stage is taken off at this point. The signal then passes to a second ceramic bandpass filter. The intention, in using two stages of ceramic bandpass filtering is to optimise selectivity.

There then follows an integrated circuit (IC) for further amplification and limiting. The signal is also passed to a separate transistor amplifier stage to provide a voltage, derived from a voltage doubler circuit., for controlling the field strength meter and inter-station muting. AM rejection is provided by the IC. The signal passes to the discriminator, and it is from this point the voltage for the centre-zero tuning meter is derived.

Audio and multiplex signals are now passed to the phase locked loop stereo decoder. This consists of a complex single IC from which the signal passes via emitter followers to low pass filters which are designed to reduce all spurious signals above 16 kHz to negligible proportions.

AM TUNER

There are two aerial inputs. One is direct to a low pass filter designed to remove signals higher in frequency than the normal AM bands and is intended for the connection of a good external aerial. The other input uses a ferrite rod aerial followed by a wide band amplifier. The alternative inputs are switched. The signal passes to a mixer which is a balanced silicon diode type. A Clapp oscillator is used because of its low harmonic content.

The wanted signal, the 3MHz intermediate frequency, is fed via an IF amplifier to a second mixer, this time a dual gate FET, where the frequency is changed to 455kHz. A second Clapp oscillator is used at this point.

The signal at 455kHz passes through a solid state ceramic filter which is followed by two stages of IF amplification at this frequency. This method of double conversion enables the whole of the medium and long wave bands to be covered in one continuous sweep without switching.

The detector follows and it is from this point that the voltage for the AM signal strength meter is taken. Automatic gain control which is applied to all three IF stages is provided at the same point. The voltage for the diode gate switching for AM selection is applied via the audio signal lead.

PRE-AMPLIFIER AND CONTROL UNIT

The signal from the disc input is fed into a two stage low noise amplifier to provide RIAA correction and to amplify the signal before it is passed via the input switching to the control unit. The sensitivity of the disc input is switchable between 3mV and 6mV for full output. The control unit input selection switching is electronic. This consists of silicon diode gates which, when the diodes are forward biased or reverse biased, conduct (open gate) or non-conduct (gate closed). This method of switching is used to minimise hum and noise, normally worsened by pick-up on the leads of a conventional switch, and to minimise switch noise when changing inputs.

The first stage of the control unit is an emitter follower providing a low impedance feed for the tone control and filter circuits. These in turn are followed by an amplifier stage with negative feedback to minimise distortion and noise. All transistors used in both control unit and pre-amplifier are selected for low noise.

The switched low frequency (high pass) filter is in circuit prior to the bass and treble tone control circuits which are of conventional Baxendall type. These are followed by the high frequency (low pass) filter/slope circuits providing switched combinations of four roll-off curves varying in frequency and slope. A voltage amplifier then precedes the balance control which is designed to reduce each channel to zero whilst leaving the other channel at normal level.

It is after this stage in the circuit that the tape output signal, in conjunction with the tape monitor facility, is taken via a variable preset potentiometer on each channel controlling the output from the specified maximum down to zero. There is also a tape output signal on the AUX socket, meeting the specified DIN standard for cassette recorders, but this output is not variable by the preset controls, nor is the tape monitor facility available on this output.

The final section of the control unit is the switched loudness circuit which is, therefore, not in circuit on the tape recording output signals. This feeds to the volume control from which the signal goes direct to the power amplifier.

POWER AMPLIFIER

The first stage of the power amplifier operates as a voltage amplifier and is used to stabilise the centre point voltage at the output. It uses a bootstrap arrangement to improve a dynamic load impedance and to enable a higher open loop gain to be obtained, which, in turn enables a higher amount of overall negative feedback to be used without reducing the sensitivity of the amplifier to any appreciable degree.

A conventional driver stage is used to drive the complementary pair of transistors which provide the phase inversion needed to drive the output pair.

The upper driver and output transistors form a degenerative Darlington and the lower driver and output transistors form an inverse Darlington. This makes it possible to reduce the quasi-complementary symmetry amplifier (which this is) to that of a complementary symmetry amplifier. The effect of this arrangement is that the output and penultimate transistors behave as single very high gain transistors.

Two negative feedback loops are provided. One is a DC loop which returns an error signal from output to input and provides the information needed to automatically correct the DC conditions within the amplifier. There is also an AC negative feedback loop to maintain the dynamic conditions to the required performance and specifications.

Power Supply. The AC input is fed via the power switch to a toroidal mains transformer with a nominal primary voltage of 117, 220 or 240 volts or via a voltage selector switch to those models which are multi-voltage. A switched AC outlet at primary voltage is taken off at this point for auxiliary equipment. In circuit with the AC input to the primary is the mains fuse and the thermal cut-out switch which operates when the output transistors heat sink reaches 80°C.

There are two secondary windings. One provides 11.5 volts for mains indicator, pilot lamps and the thermal delay switch. The latter is designed to delay the main rail reaching full voltage until several seconds after switch-on. A 47ohm resistor is in circuit until this delay switch operates which then by-passes it.

The other secondary winding via the bridge rectifier provides the main rail voltage which is 83 volts, off load. This goes through separate 2.5A fuse links to each power amplifier and there is a stabilised circuit via a 160mA fuse to provide the 45 volt line. This is then taken via separate stabilised circuits to the individual modules, the voltages in each case being shown on the circuit diagram.

The 11.5 volt AC supply is fused at 2.5A, on the earth side, in the case of models 621, 625 and 626 but not models 623 and 624.

TEST AND ALIGNMENT PROCEDURES FOR SERIES 600

These procedures are intended as a general guide for use by experienced engineers. Reference should be made to the full published specifications if a complete test is to be carried out.

Equipment required:

This should all be of high quality or accurate test results will be impossible. Series 600 has been designed to an exact and high standard, and will in general, have a standard of performance that will be better than all but the best test equipment.

- 1). FM or FM/AM Generator.
- 2). Two AM Generators. (One of these can be a normal general purpose service instrument.)
- 3). Stereo Generator.
- 4). Audio Output Meter.
- 5). Low Distortion Audio Oscillator (0.02%).
- 6). Distortion Measuring (THD) Equipment.
- 7). Frequency Counter.
- 8). Oscilloscope.
- 9). Two 8 ohm loads.
- 10). 2mfd paper capacitor 100V AC.

Setting Up: General

Select correct mains supply voltage setting.

Connect 8 ohm load across output.

Connect earth to chassis if not earthed via a 3 core mains lead.

Avoid earth loops between items of test equipment.

Reduce volume control to zero between each test.

All FM signal levels are P.D. across, 75 ohms.

Audio Test Procedure and Specification Models 621, 625, 626.

Quiescent Current. (Volume control at zero).

Turn both 221L and 221R preset potentiometers on A17 module fully anticlockwise, and then adjust each one so that respective output transistor currents are 5mA. (Unsolder collector lead and insert meter for this check).

IMPORTANT - SWITCH AMPLIFIER OFF while connecting meter in or out of circuit.

Power Test

Connect input from audio generator to tape input and connect output meter and 8 ohm loads to LS 1 output. Set bass, treble and balance controls to 12 o/c. Depress mono button and L/S 1 button, set selector switch to tape, and volume control to maximum.

Inject 1kHz signal and adjust input level of signal for maximum output. Each channel should give a minimum of 18.5 volts before clipping takes place. (Both channels driven).

Distortion and Stability Test

Reduce input signal so that each channel is delivering 18 volts output. Distortion should be less than 0.06% on each channel. Switch 2mfd capacitor across load resistor on each channel in turn and check that no rise in the distortion reading occurs.

Tape Sensitivity, Tape Recording Output and Frequency Response

Release mono button (stereo mode). Adjust input signal for 18 volts output, channel matching should be within 0.5db. Input signal should be 250 millivolts \pm 1db to obtain 18 volts output.

Depress tape monitor switch and check both channels give same figures as prior test.

Release tape monitor switch and check crosstalk is 45db or better.

Check tape output. Output should be from zero to 250 millivolts each channel by rotation of tape output level controls 203L 203R, on underside of chassis.

Reduce input until output is reading 0db on the 3 volt range meter.

Sweep input frequency from 25Hz - 20kHz. Response should be within ± 1 db through the range. NOTE: For this test it is permissible to adjust the bass and treble controls 5 degrees either side of centre.

Tone Controls

Reset bass and treble controls to the central position (12 o/c). Change input frequency to 14kHz and adjust for 0db on the 3 volts range. Treble control should now lift 13db and cut 13db. Tolerance -1db +2db. Reset treble control to 12 o/c.

Change input frequency to 70Hz and adjust for 0db on 3 volt range. Bass control should lift 15db and cut 15db. Tolerance -1db +2db. Reset bass control to 12 o/c.

Filters

Depress Filter 1 switch, adjust input frequency to 1kHz and set for 0db reference on 3 volt range. Increase frequency until signal drops -3db. Frequency should be between 4.8 and 6kHz. Depress slope switch and adjust frequency until output is again at the -3db point. The frequency should now be between 2.2 and 5kHz.

Release Filter 1 switch and depress Filter 2. Adjust frequency again for the -3db point, frequency should be between 7.5 and 8.5kHz. Release slope switch, adjust frequency to the -3db point. Frequency should now be between 8.5 and 10kHz. Release Filter 2 switch.

Depress low filter switch and adjust frequency for the -3db point. Frequency should be between 100Hz and 150Hz.

Loudness

Adjust input at 1kHz to give a reading of 0db on the 3 volt range of output meter. Depress loudness switch. Output should drop 20db. Reset input frequency to 70Hz. Output should rise to 10db (this reading is -10db relative to 0db on 3 volt range at 1kHz).

Reset input frequency to 14kHz. Output should rise 5db (this reading is -15db relative to 0db on 3 volt range at 1kHz).

Release loudness switch.

Transfer 8 ohm loads to the alternative output. Release L/S 1 switch and depress L/S 2 switch. Output should still be 0db reference on 3 volt range at 1kHz.

Radio and Aux Inputs

Transfer input to Radio and Aux inputs in turn, and set selector switch to the appropriate input. Adjust signal to give an output of 18 volts on each channel respectively. Input should be 120 millivolts \pm 1db at 1kHz.

Note that from serial number 632801 onwards a second tape recording output is provided from the AUX socket. This is not adjusted by the tape output level potentiometers. The stereo output is to the DIN standard.

Volume Control matching and Balance Control

Set input level for 0db on 10 volt range of output meter. Adjust volume control so that output falls -46db. Channel matching at this point should be within 2db. Turn volume to maximum and check the operation of balance control by reducing each channel to zero in turn.

Reset balance control to 12 o/c.

Disc Input, Sensitivity and RIAA

Transfer input signal to disc input and change function switch to disc. Adjust input at 1kHz for 18 volts output, input should be 3 millivolts \pm 1db with switch sensitivity (on C28, underside of Receiver) set to LOW and 6 millivolts when set to HIGH.

Check overload at 1kHz on low setting, this should be not less than 70 millivolts for 1% distortion.

With sensitivity switch on low input, check RIAA response by sweeping from 30Hz to 20kHz. Output should be \pm 1db of RIAA response over the whole range.

Headphone Jack

Insert headphones into jack and check for signal on both channels. Remove signal input and, still using headphones, check for silent operation of all switches and controls. Remove headphones

Hum and Noise

Insert shorting plug into P/U input and, with volume control at maximum, check that the hum and noise on all inputs is better than -65db, relative to 18 volts output.

FM RF Test Models 623, 624, 625 and 626.

(Where the term Receiver is used in these procedures it applies to 623 and 624 Tuners as well as to 625 and 626 Receivers).

Check cursor moves exactly from end to end of dial aperture then set cursor to left hand end of dial. (If not done previously on AM test 623 - 626).

I.F. Alignment

Set mute preset R97 (on F16) fully anticlockwise and set the 98MHz preset R115 and preset R111 to midway positions.

Switch unit to radio, connect L/S 1 output to 8 ohm load and select appropriate L/S switch.

All other switches out except Distant, AFC and Tune which must be depressed.

Set balance and tone controls to 12 o/c and volume control should be set at a position to give reading on 10V range of output meter.

Set signal generator to approximately 10.7MHz at 75kHz deviation (400Hz modulation) and inject signal into pin M5 on F16, approx 200 micro-V and tune generator for maximum deflection on Receiver tuning meter. Note: THE GENERATOR MUST BE CAREFULLY TUNED TO MAXIMUM SO AS TO ALIGN WITH THE CERAMIC FILTERS. DO NOT RE-ADJUST GENERATOR FREQUENCY FOR THE REST OF I.F. ALIGNMENT.

Adjust top and bottom cores PDT3 transformer on F16 for absolute maximum on the output meter. DO THIS CAREFULLY, THE PEAK TUNING POINT IS IMPORTANT.

Transfer signal generator to gate 2 on mixer FET of F15 (12K, resistor 60).

Do not adjust frequency.

Inject 1mV and tune IFT67 transformer on F15. Adjust top and bottom cores for maximum reading on Receiver tuning meter. This adjustment is also critical and must be tuned carefully. With 60 micro-V input, the output should just be showing some noise on the trace.

Front End Alignment

Short out AFC pin K9 on F15 to earth.

Transfer signal generator to aerial input via co-axial socket (75 ohms) and adjust frequency to 88MHz.

- A. Tune Receiver to 88MHz and adjust the 4 cores of FMO83, FMR82, FMR84, FMR81, in this order, for maximum output on Receiver tuning meter.
- B. Adjust signal generator to 108MHz. Tune Receiver to 108MHz and adjust the trimmers 377, 368, 360, 357 in this order for maximum on tuning meter.

NOTE: TRIMMER 356 (IF FITTED) SHOULD BE SET TO MINIMUM BEFORE A - B ABOVE.

Repeat adjustments A & B until no further improvement can be obtained.

Set signal generator to 98MHz, tune Receiver to 98MHz and adjust preset 115 on F16 for maximum output. Re-check A & B and re-adjust if required. Tune Receiver to 98MHz and set generator to this frequency. Adjust trimmer 356 (if fitted) and trimmer 357 for maximum sensitivity. As 356 is increased in value 357 must be decreased.

Sensitivity: Check 90MHz 2 micro-V for 30db quieting.

Full Limiting

Tune signal generator and Receiver to 98MHz and adjust input level so that full limiting occurs. Adjust volume so that a reading of 0db is obtained on 10v range of output meter. Reduce input signal so that output drops 1db. Signal level should read 2.5 micro-V or less.

Muting

When the above tests are completed set MUTE LEVEL. Release distant switch and with signal generator and Receiver still set at 98MHz set input level to 10 micro-V.

Adjust mute preset 97 on F16 - so that signal just goes off, then turn back so that the signal just restores. (The tuning must be exact for this adjustment).

Check that signal goes on and off over a 2db range of input signal.

Check Tuning Meter Range

Distant switch OUT 100 micro-V to 10 milli-V.)
Distant switch IN 8 micro-V to 100 milli-V.) APPROX READINGS

Remove AFC SHORT (Pin K9 on F15).

Automatic Frequency Control

With Receiver still tuned to 98MHz inject 1 milli-V and detune signal generator slowly either side of 98MHz and note the range that AFC holds the signal. This should not be less than $\pm 300\text{kHz}$.

Noise

Reduce generator deviation to 25kHz and inject 30 micro-V at 98MHz. Set volume control to give a reading of 0db on the 10 volt range of output meter. Reduce signal input to 4 micro-V and check that the noise is 55db down on both channels. Increase generator to 1mV input and at full volume check that clipping occurs before 25% modulation is reached.

Tuning Meter

Release AFC button and check tuning meter for centre tuning.

Decoder Alignment

Connect a frequency meter to coil MS76 (this point can be picked up on 421, 3300pf) and adjust the core of MX76 carefully to 76Hz.

Tune Receiver to a stereo generator connected to aerial input (75 ohms), 19kHz pilot switched OFF and modulation set to 23kHz. Adjust ferrite coil (if fitted) core for maximum rejection. This coil was only fitted on early models.

Switch pilot tone on and set modulation frequency to 1kHz. Adjust RF output from stereo generator to 100 micro-V. Check channel separation which should be at least 38db. Check stereo indicator functioning correctly.

Set all FM station presets to 98MHz, or required frequencies, checking Receiver frequency meter whilst tuning. Alignment is now complete for FM.

623 and 624 Tuners only

High output on tuners to be 0.775V, reference 0db on 1V scale of high impedance output meter \pm 1db, both channels. Low output should be 6db less both channels, when matched into 68K load.

AM RF Test Models 623, 626.

Check cursor moves exactly from end to end of tuning scale aperture, then set cursor to left hand end of scale (if not done previously on FM test).

Turn selector switch to Radio, depress switches Tune and AM ()

I.F. Alignment

Connect AM signal generator (modulated 30%) to pin R1 on F13 module. Adjust generator frequency to 455kHz \pm 500Hz. Output meter on 3 volt range. Volume control at 12 o/c. Adjust generator output for a middle of scale reading on output meter.

Tune top core of IFT66, top and bottom cores of IFT65, top core of T12.5 in that order. Reduce input signal level during alignment to keep output meter in centre of range.

Transfer generator lead to pin Q9 and change frequency to 3.1mHz \pm 0.01mHz. Tune core of OS77B and the top and bottom cores of IFT61, in that order.

Transfer generator lead to pin R2 and tune top and bottom cores IFT79 and also IFT61 again.

This completes I.F. alignment.

Front End Alignment

A. Set Receiver to 200kHz (20) and feed into AM EXTERNAL aerial socket a generator signal of 200kHz at approx 100 microvolts.
Adjust core of OS77A for maximum signal.

B. Reset cursor and generator to 1300kHz (130) and adjust trimmer 343 for maximum signal.

Re-check A and B in sequence until calibration at both ends is correct.

Re-set cursor and generator to 700kHz. Adjust preset 111 on F16 for maximum output.

Re-check 200kHz and 1300kHz.

Sensitivity:- at 700kHz, 100mV input should deflect field strength meter to a reading of half scale.

Tune Receiver to 300kHz. Set one generator to 1300kHz 10mV output. The other to 1mHz with 100mV output. Connect both generators to aerial input. Adjust trimmer 308 and preset 8 to remove resulting beat signal. Receiver tuning should be rocked for optimum point.

N.B. The trimmer and preset must be adjusted simultaneously.

Set Receiver to 1300kHz (130) and generator to 1300kHz. Switch to internal aerial.

Fit 5-turn coupling coil over ferrite rod in the centre and connect to generator. With an output of 10 micro-V (approx), signal should be apparent but with slight noise.

Check AM preset tuning control potentiometers.

QUALITY CONTROL PROCEDURES

QUALITY CONTROL - AUDIO 621/5/6

1. Shake set and listen for any loose bits. Inspect set visually.
2. Turn tape outputs to maximum and P.U. switch to low.
3. Connect headphones to LS 1 outputs and signal to tape input.
4. Connect mains, switch on and check pilot lamp is working. Switch mains switch on and off at least six times.
5. Switch selector to TAPE and switch on LS 1, ensuring no output is present before LS 1 switched.
6. Switch input box to T/R/A, advance volume control. Check each channel is working on each of A & B switch positions, with tape monitor switch both in and out, with signal showing on scope on all functions.
7. Check that tape output pots reduce and increase signal on both channels and leave turned to maximum. Leave switch on A.
8. Switch to Mono, signal should be on both channels.
9. Change headphones to LS 2 first ensuring LS 1 switches headphones off. Check that phones are not working until LS 2 switch is pressed.
10. Check balance, treble and bass controls.
11. Check that loudness switch reduces volume and that both channels are working with this in.
12. Check Slope, High 1, High 2 and Low. Check all switches for silent operation.

13. Release mono switch, turn down volume control, change input signal to DISC, change switch box to DISC and check A & B channels. Check with sensitivity switch on both high and low positions, leaving switch set to high.
14. Check that tape monitor switch cuts out signal on both channels and that loudness switch reduces signal on both channels and that both channels are working with loudness switch down.
15. Remove input signal, turn volume control to 2 o/c and listen for higher than average background noise. If excessive on open input, even though normal on shorted input, set should be rejected.
16. Connect input signal to AUX and check A & B channels, re-checking tape monitor function.
17. Switch off LS 2 and change headphones from LS 2 output to headphone jack socket, ensuring that there is still output from both channels.
18. Change input signal to TUNER, checking A & B channels (621 only).
19. Switch 621 on and off at least six times, ensure signal still present on both channels and then disconnect.
20. INSULATION AND FLASH TEST
 - (a). Connect 621 to Insulation Test Set SAFELOC and the earth clip (green wire) to earth terminal of 621.
 - (b). Press button 'A' for 3 seconds; reading on EARTH CIRCUIT meter (left hand side) should be less than 0.15 ohms.
 - (c). Press button 'B' and hold for 3 seconds; centre KV meter should read 2KV and right hand Megohm meter should read not less than 5 Megohms. If flash-over occurs the RED fault lamp will light and the Voltmeter and Megohm meters will return to zero.
21. Inspect 621 for finish particularly case and front panel.
22. Clean 621, including back of set and underside of plinth, ensuring four feet and nameplates are firmly in position.
23. Put 621 in poly bag, put Instruction Book with Guarantee Card and Safety Addendum, inside front cover, on top of case and thread safety label on mains lead. Put on trolley for packing.

NOTE: Check for intermittent connections at all stages of test by banging set on bench in the prescribed manner.

QUALITY CONTROL - FM 625/6.

1. Select TUNER, switch to DISTANT, check for instability by tuning from one end of scale to the other ensuring there is an even noise level all along the band.
2. Plug in FM aerial and release DISTANT switch.
3. Select TUNE. Using knob, tune from one end of the dial to the other, checking for smooth drive, freely working upper tuning meter, clean and scratch free tuning scale and that cursor reaches both ends of the scale.
4. Tune to 89.1mHz and 95.8mHz checking calibration (or other frequencies as appropriate to location).
5. Press AFC switch. Check that with DISTANT switch up lower meter on 89.1mHz reaches 3/4 scale and reaches full scale with DISTANT switch down. Release AFC switch.
6. Tune to 103mHz. Check that with DISTANT switch up there is no noise and with switch down there is noise.
7. Tune to a point where a strong station is almost in tune but distortion can be heard. Press AFC switch and check that distortion clears up.
8. Tune to Radio 2 or 3 (or other stereo broadcast appropriate to location) and check that stereo beacon lights
9. Select each preset key in turn and tune in a station on each of the six knobs (three on 626).
10. Listen for excessive noise on all press keys with volume control at normal setting.
11. Switch between presets several times ensuring that tuned stations remain on tune.
12. Check for intermittent connections on FM by banging set on bench in the prescribed manner.

13. Switch 625 on and off at least six times, ensure signal still present on both channels and then disconnect.

14. INSULATION AND FLASH TEST
 - (a). Connect 625 to Insulation Test Set SAFELOC and the earth clip (green wire) to earth terminal of 625.
 - (b). Press button 'A' for 3 seconds; reading on EARTH CIRCUIT meter (left hand side) should be less than 0.15 ohms.
 - (c). Press button 'B' and hold for 3 seconds; centre KV meter should read 2KV and right hand Megohm meter should read not less than 5 Megohms. If flash-over occurs the RED fault lamp will light and the Voltmeter and Megohm meters will return to zero.

15. Inspect 625 for finish, particularly case and front panel.

16. Clean 625 including back of set (especially the self-adhesive back plate) and underside of plinth, ensuring four feet and nameplates are firmly in position.

17. Put 625 in poly bag, put Instruction Book with Guarantee Card and Safety Addendum inside front cover, on top of case, thread safety label on mains lead. Put on trolley for packing.

QUALITY CONTROL - AM 626

1. Check AM aerial switch is on EXTERNAL, connect an aerial. Select AM and select TUNE.
2. Tune to 200kHz, and 1200kHz. Check calibration is correct that upper tuning meter is working freely and that tuning meter works.
3. Select each preset key in turn and tune in a station on each of the three knobs.
4. Disconnect AM aerial and switch to INTERNAL.
5. Repeat step 2 and re-check presets 1, 2 and 3.
6. Switch between presets several times ensuring that tuned stations remain on tune.
7. Check for intermittent connections on AM by banging set on bench in the prescribed manner.
8. Switch 626 on and off at least six times, ensure signal still present on both channels and then disconnect.
9. INSULATION AND FLASH TEST
 - (a). Connect 626 to Insulation Test Set SAFELOC and the earth clip (green wire) to earth terminal of 626.
 - (b). Press button 'A' for 3 seconds; reading on EARTH CIRCUIT meter (left hand side) should be less than 0.15 ohms.
 - (c). Press button 'B' and hold for 3 seconds; centre KV meter should read 2KV and right hand Megohm meter should read not less than 5 Megohms. If flash-over occurs the RED fault lamp will light and the Voltmeter and Megohm meters will return to zero.
10. Inspect 626 for finish, particularly case and front panel.
11. Clean 626, including back of set (especially the self-adhesive back plate and ferrite aerial) and underside of plinth, ensuring four feet and nameplate are firmly in position. •
12. Put 626 in poly bag, put Instruction Book, with Guarantee Card and Safety

The Series 600

Circuit Data

Power-supply and Amplifier sections 621 Amplifier, 625 and 626 Receivers (single voltage models)

see panel A for details of power supply for multi voltage sets

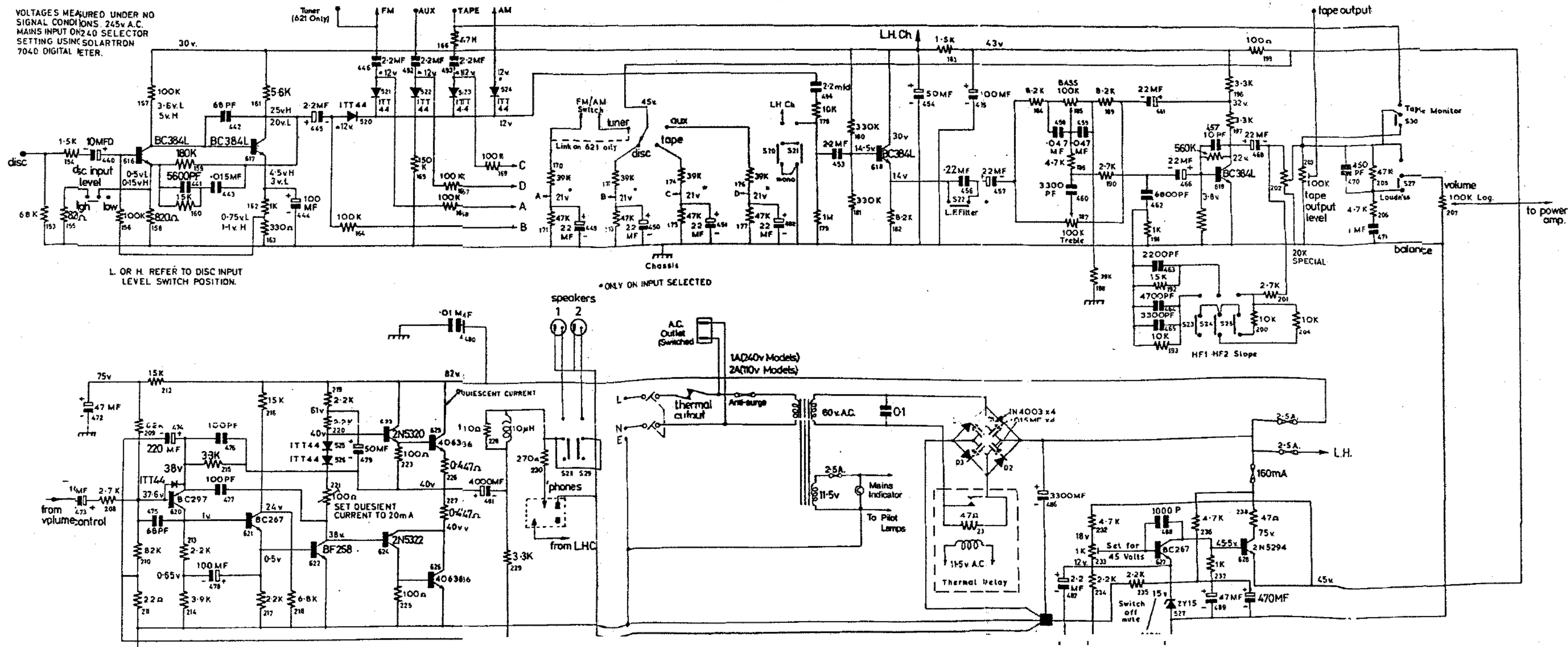

A

For Service Manuals Contact
MAURITRON TECHNICAL SERVICES
8 Cherry Tree Rd. Chinnor
Oxon OX9 4QY
Tel: 01844-351694 Fax: 01844-352554
Email: enquiries@mairitron.co.uk

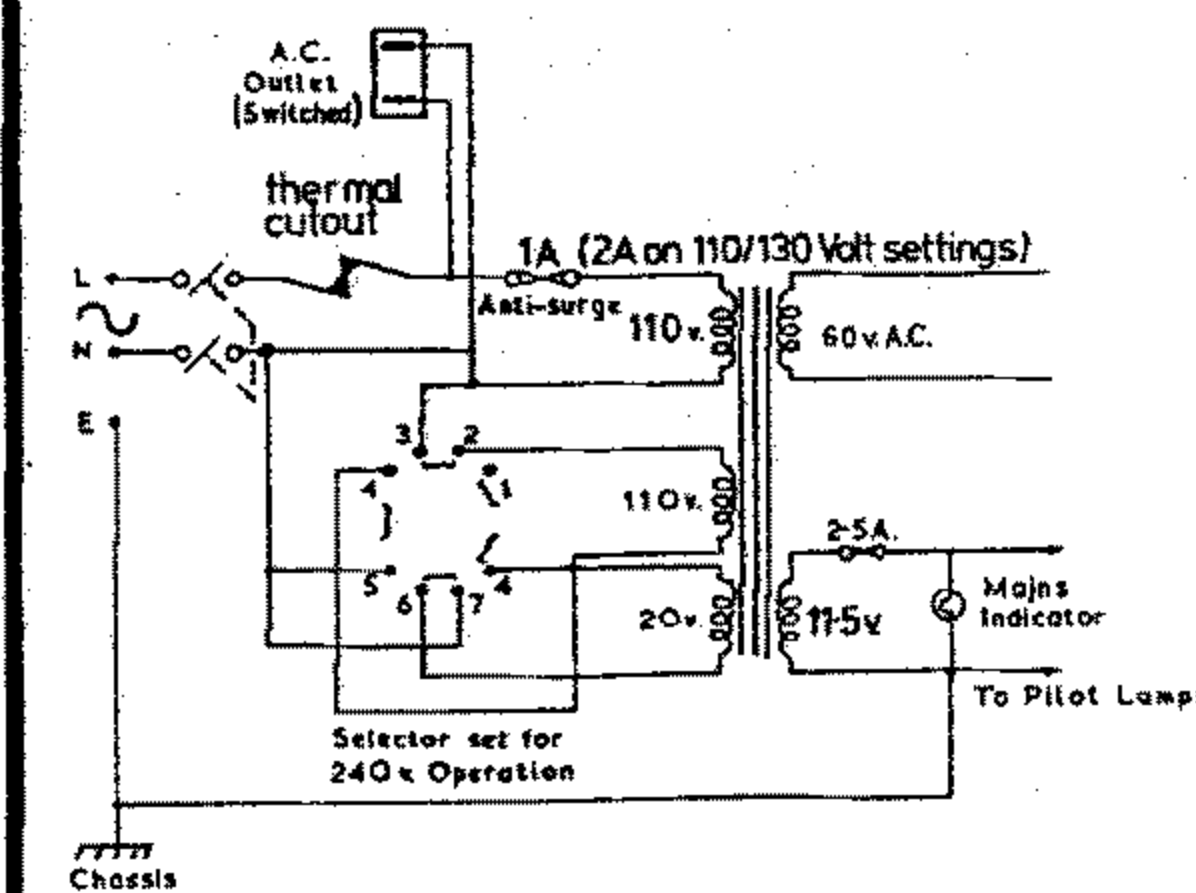

Tuner sections 623 and 624 Tuners 625 and 626 Receivers

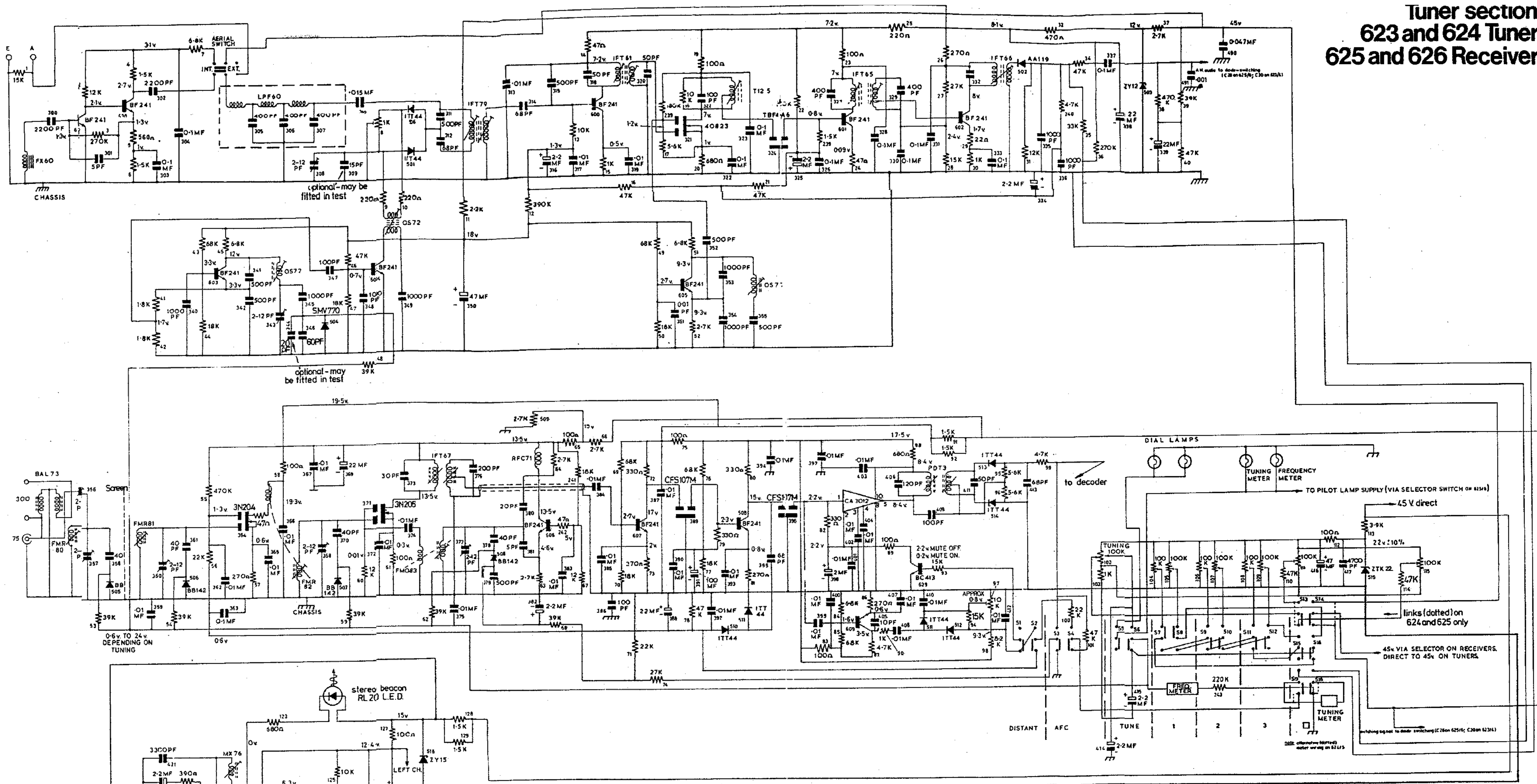

Power-supply and Output 623 and 624 Tuners

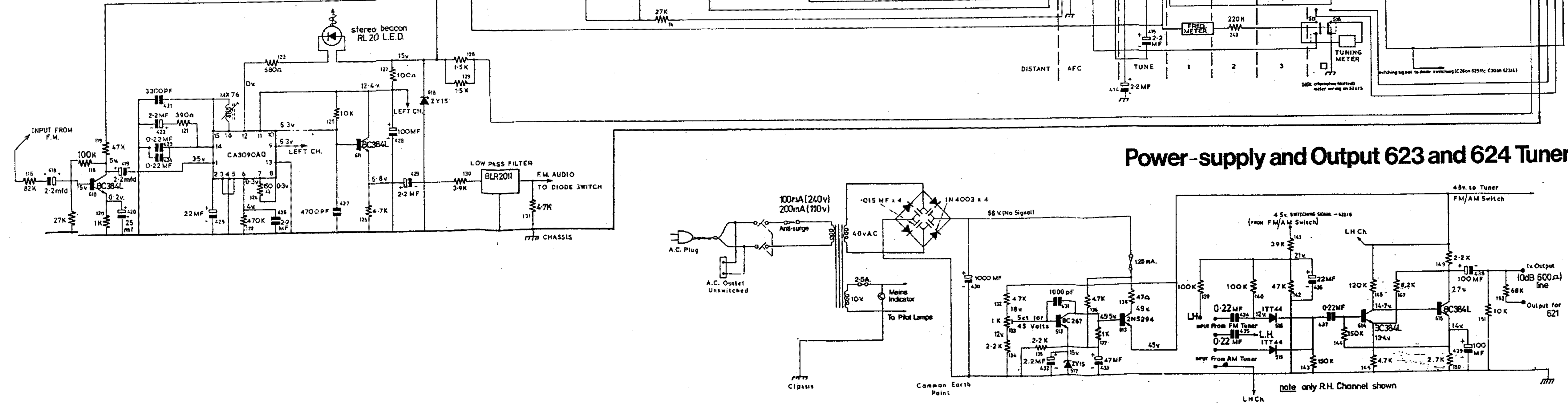

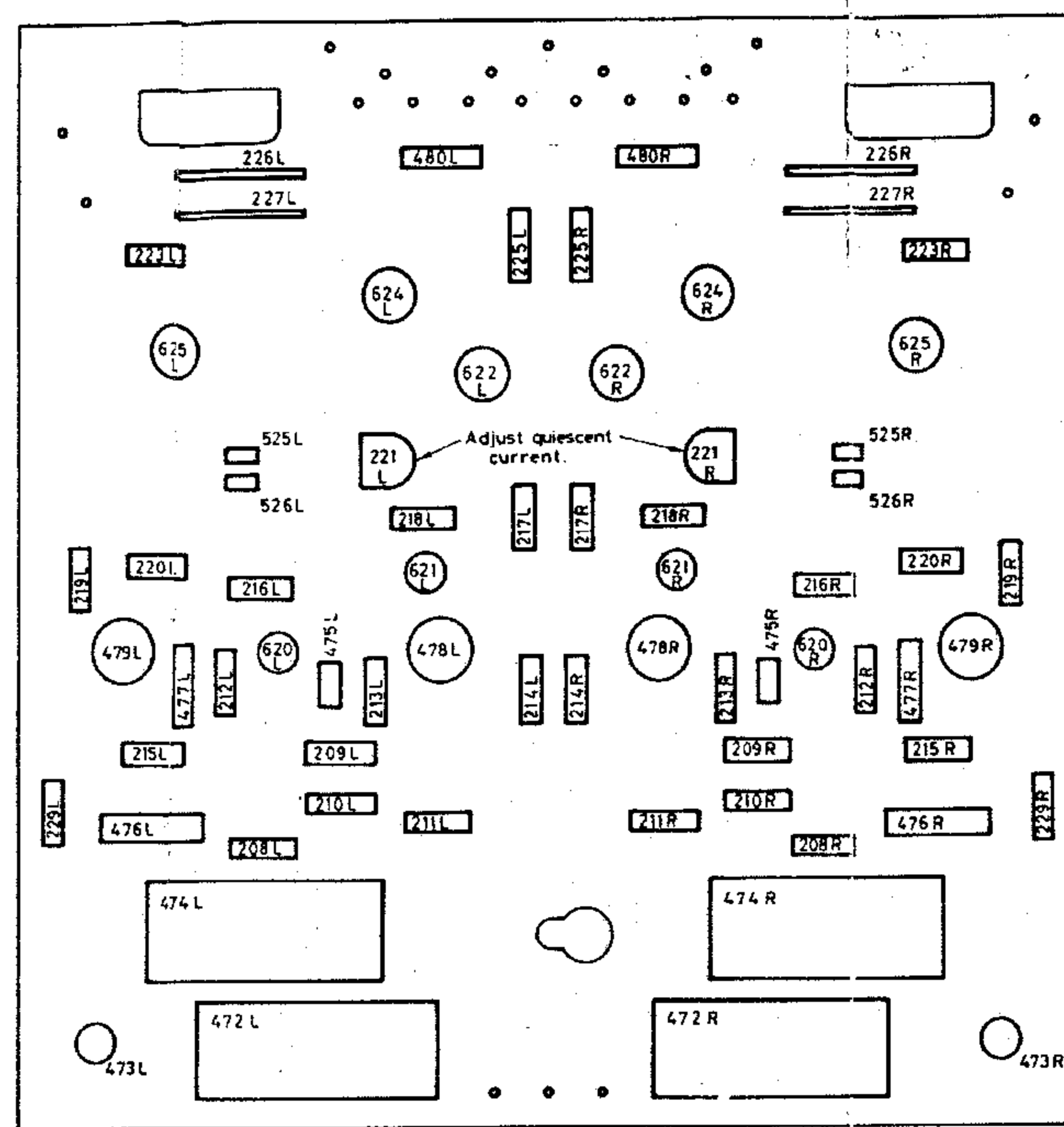

A17 Power amplifier

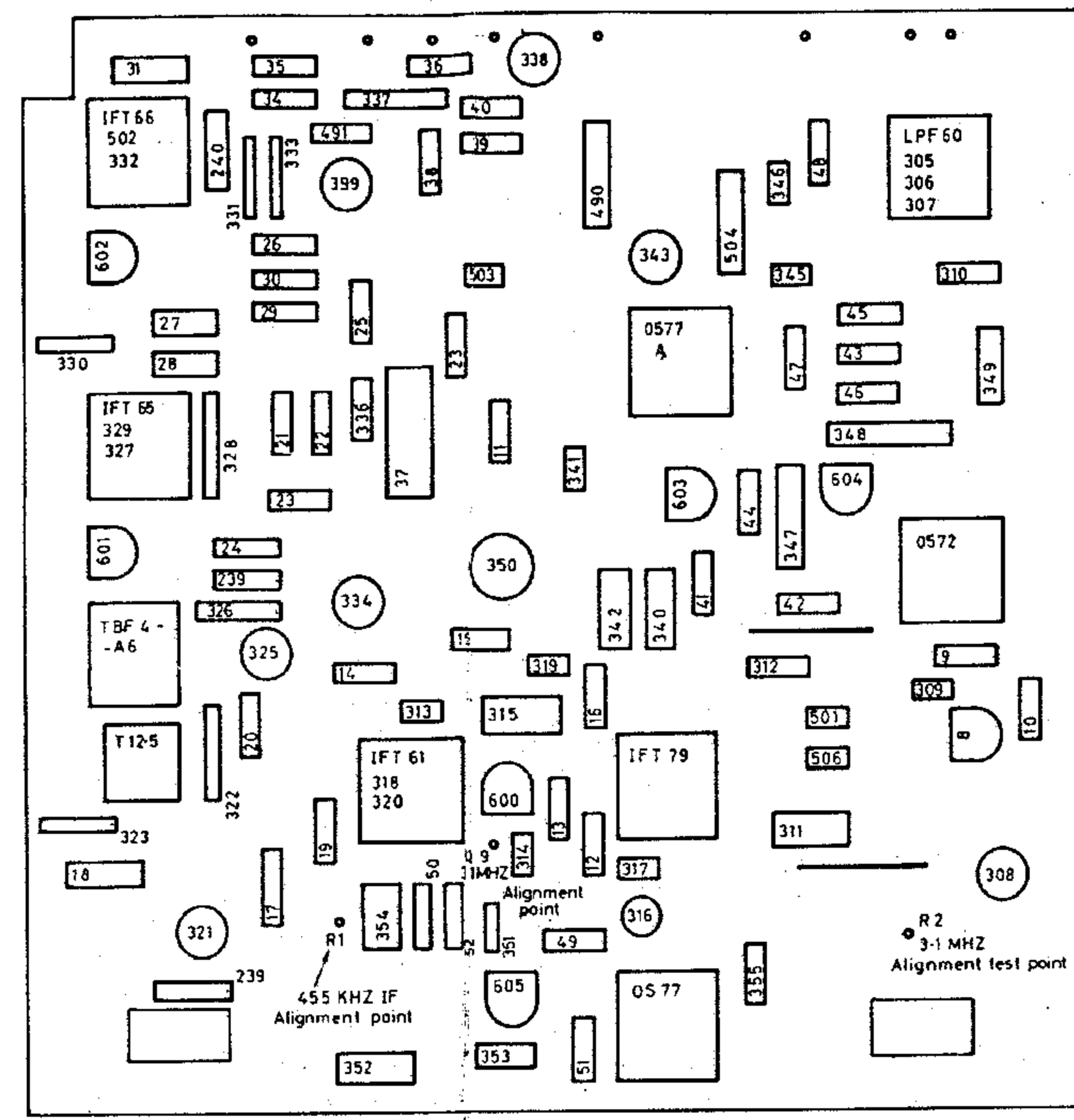

F13 A.M. tuner

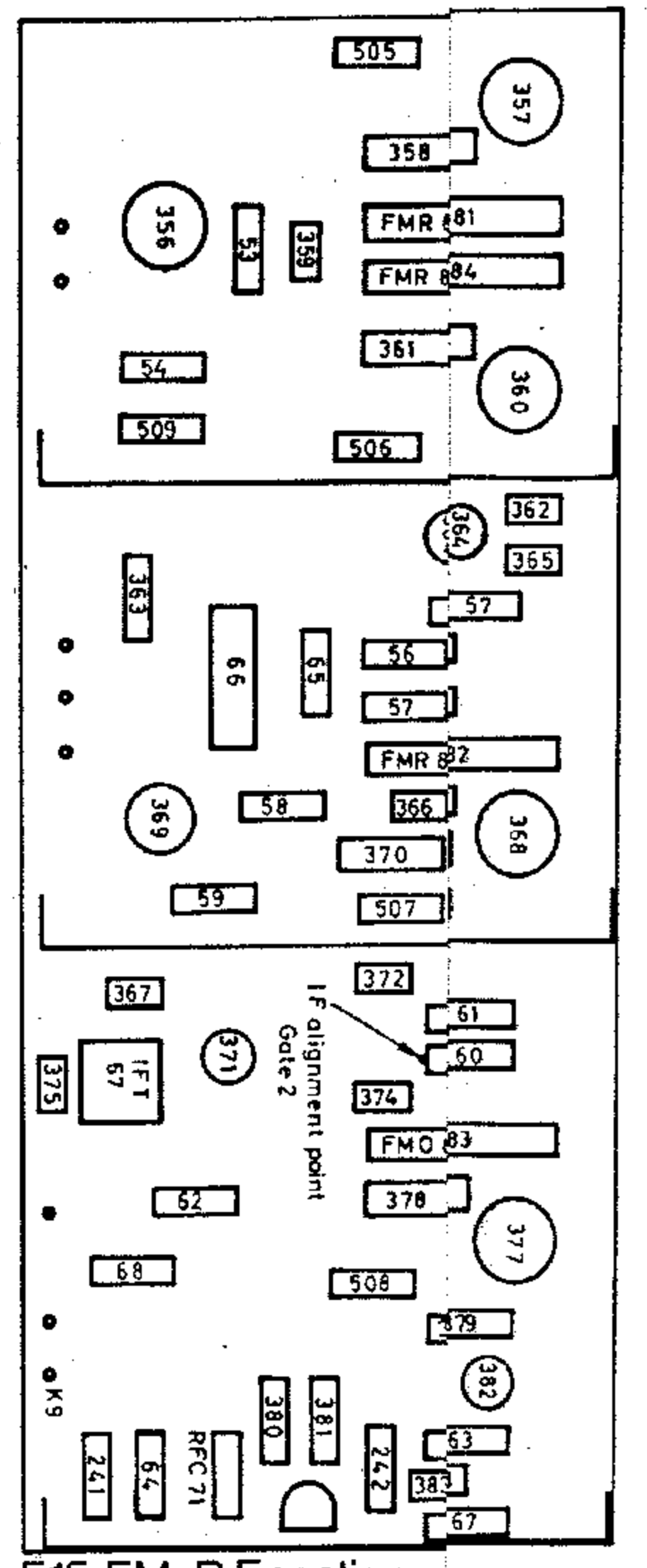

F15 F.M. R.F. section

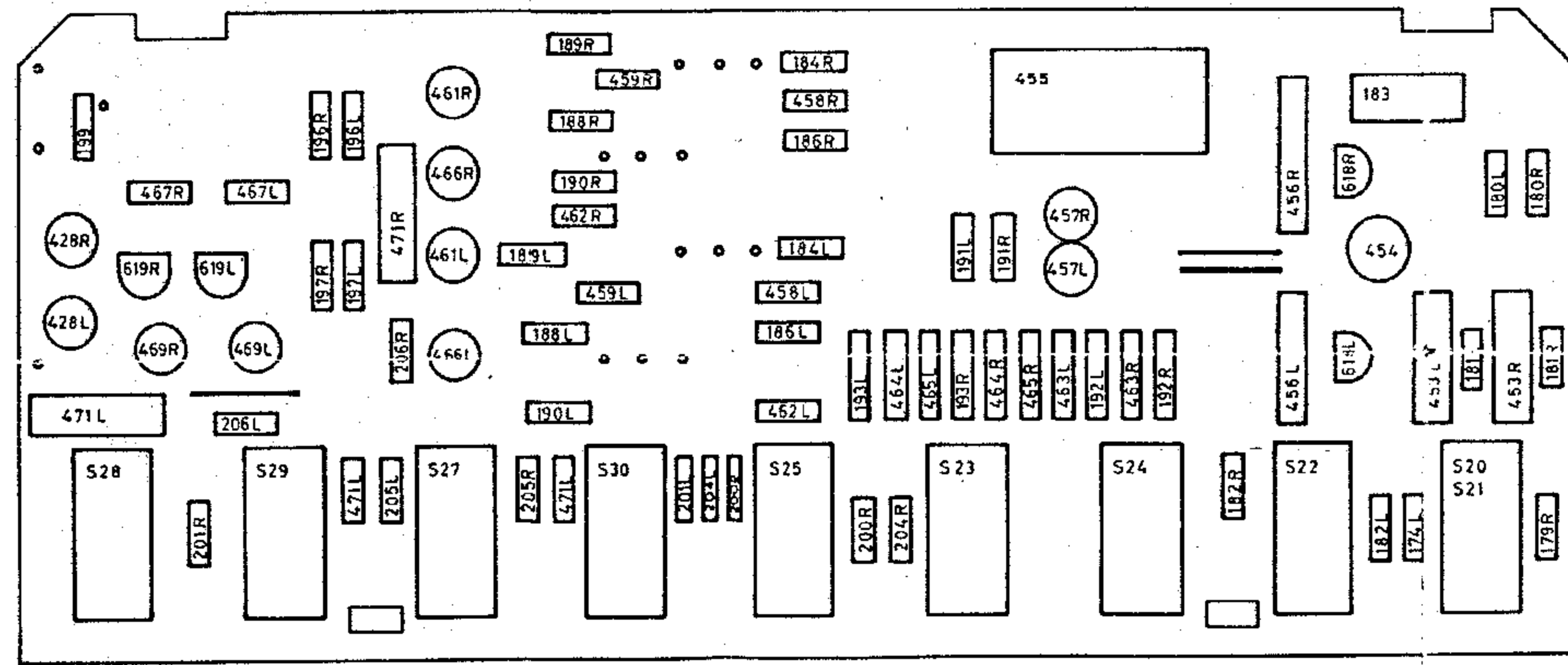

C29 Control unit

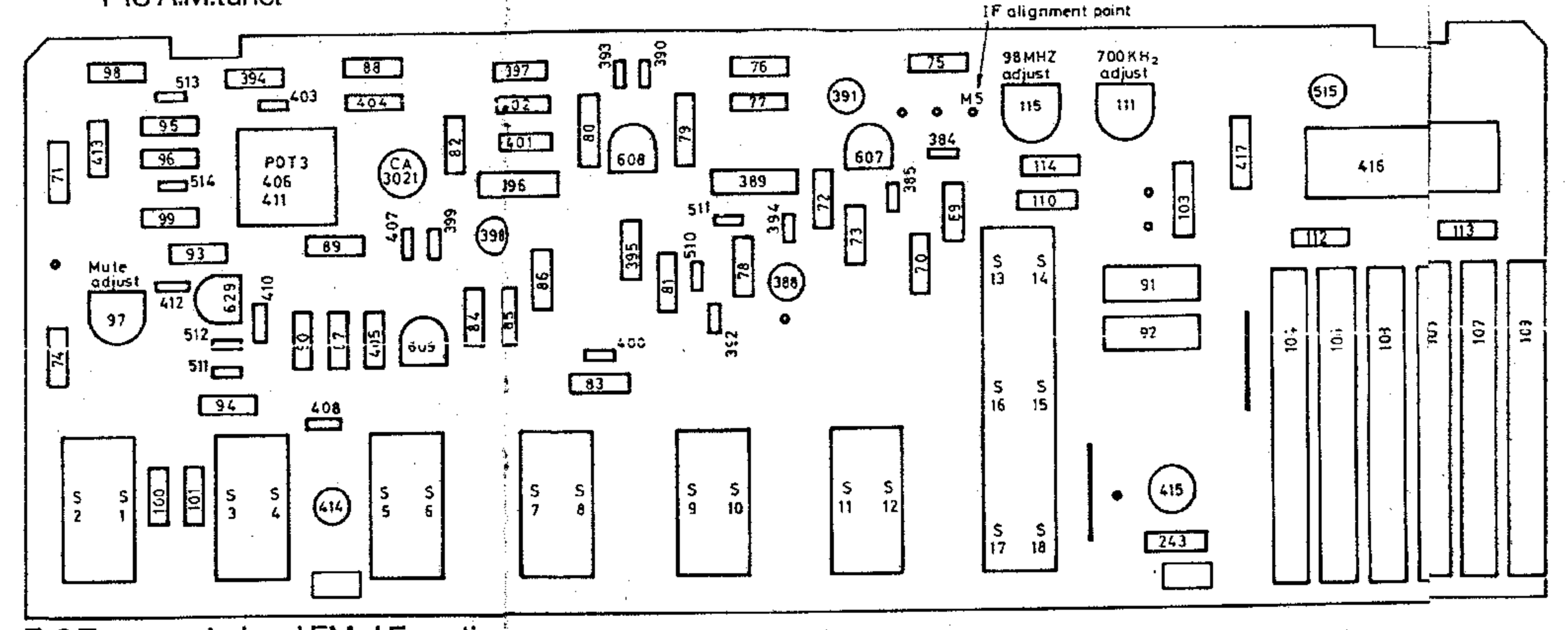

F16 Tuner control and F.M. I.F. section

Top View

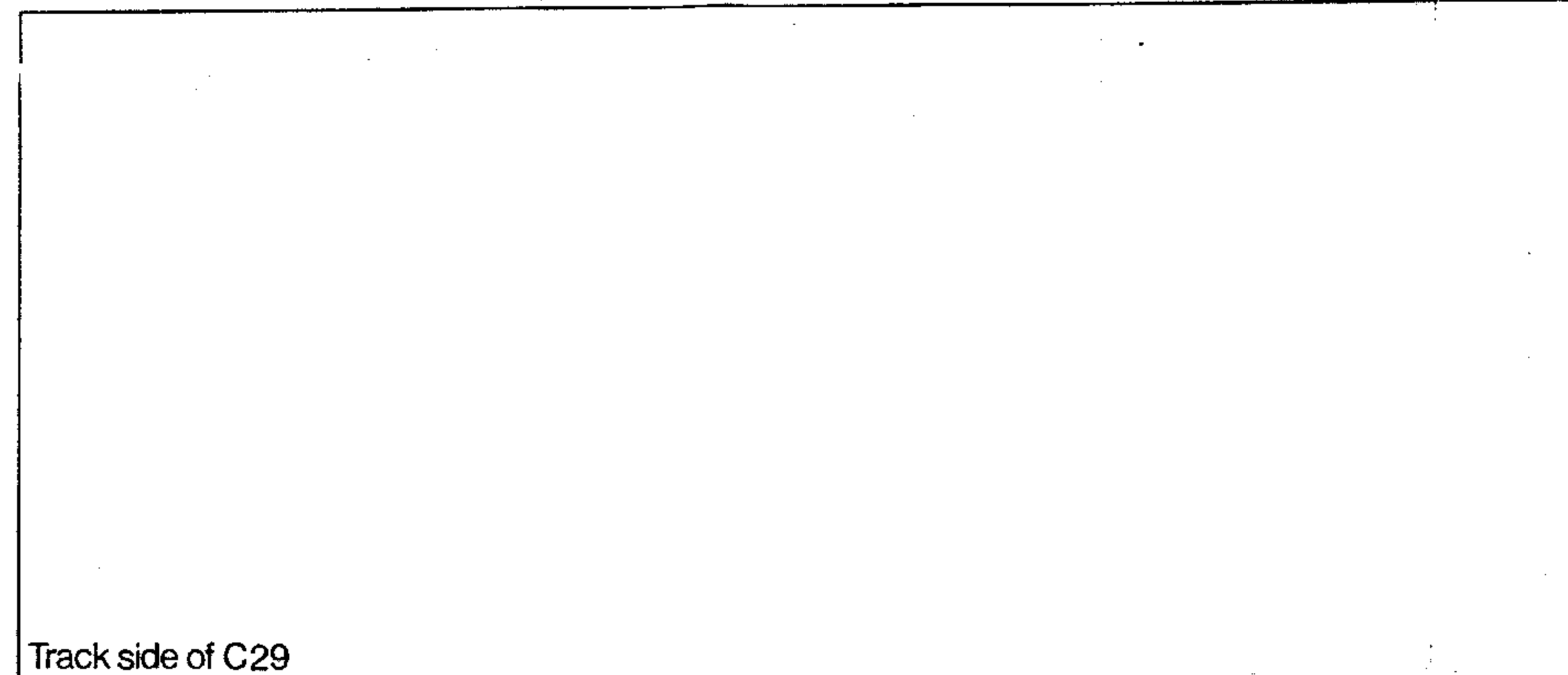

Track side of C29

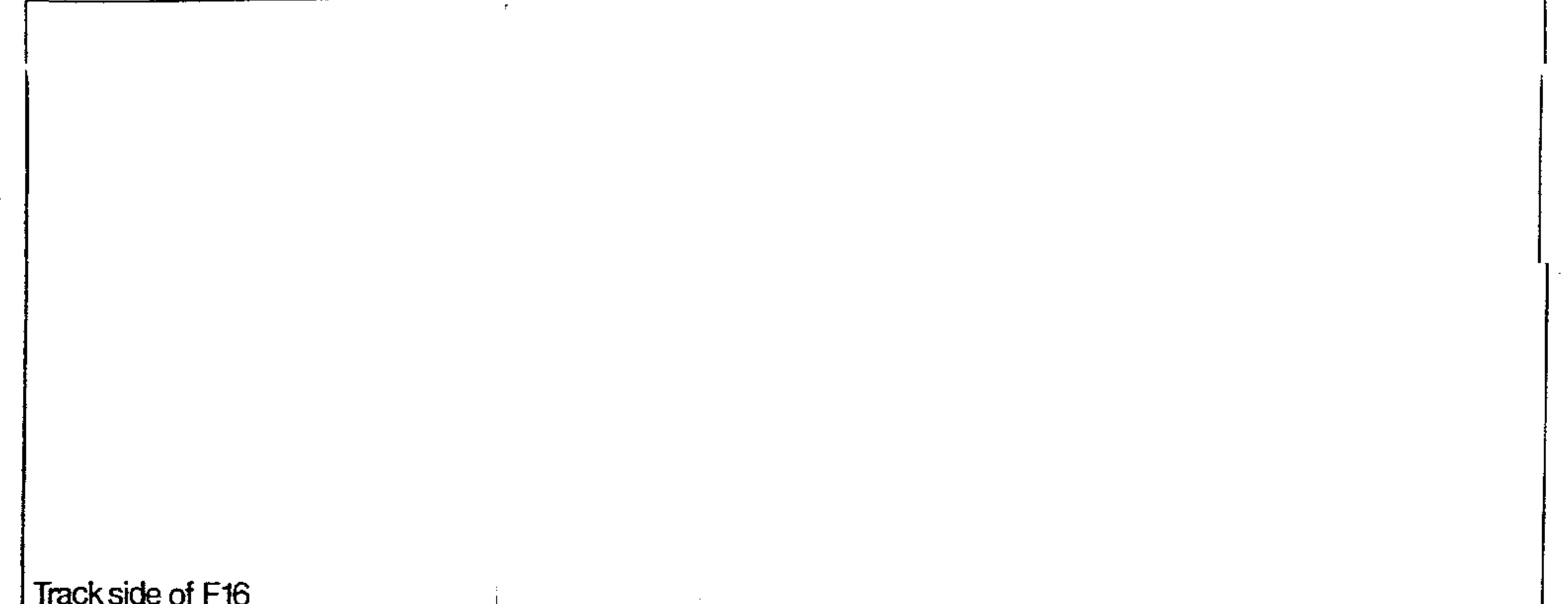

Track side of F16

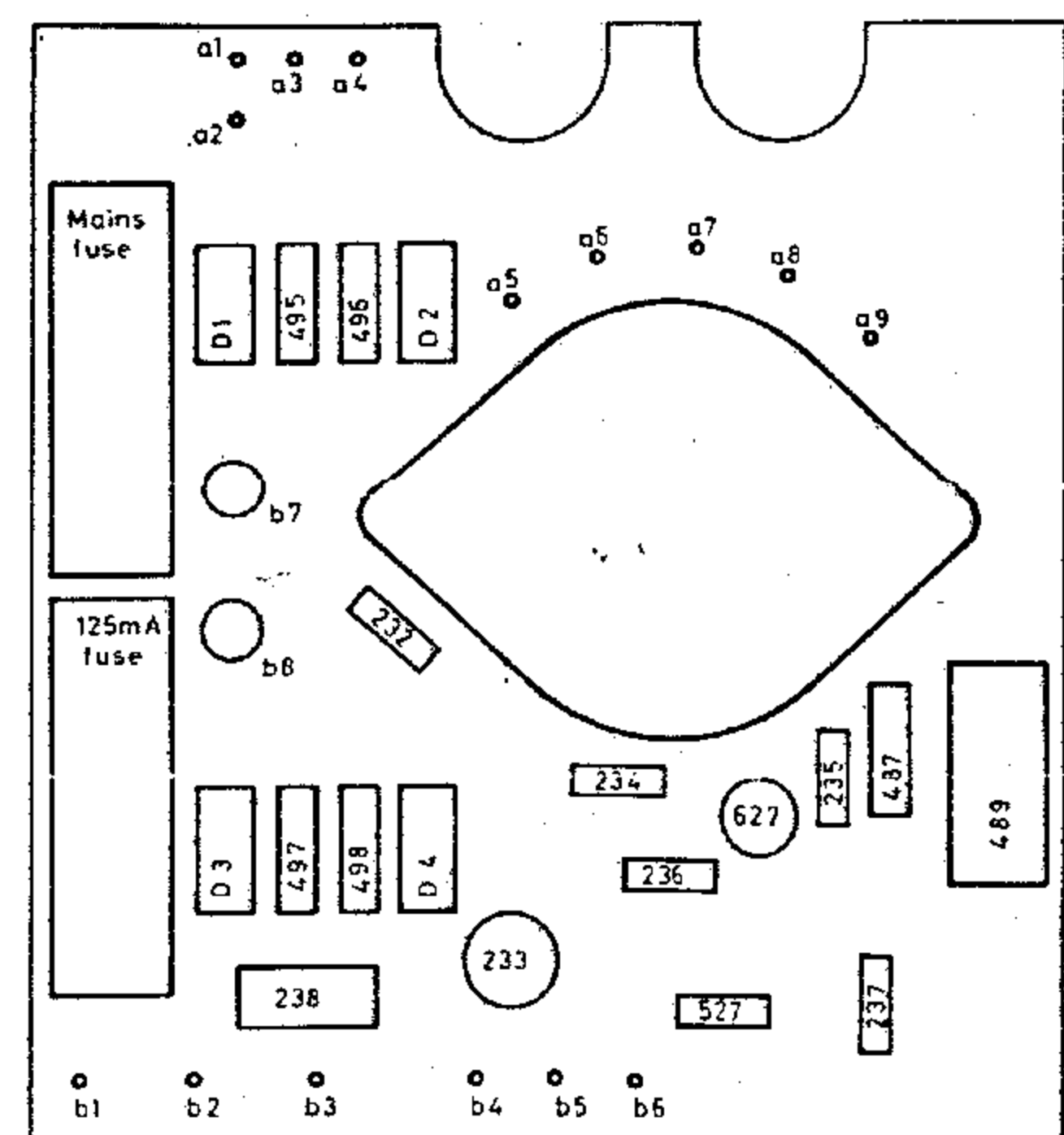

Z20 Power supply

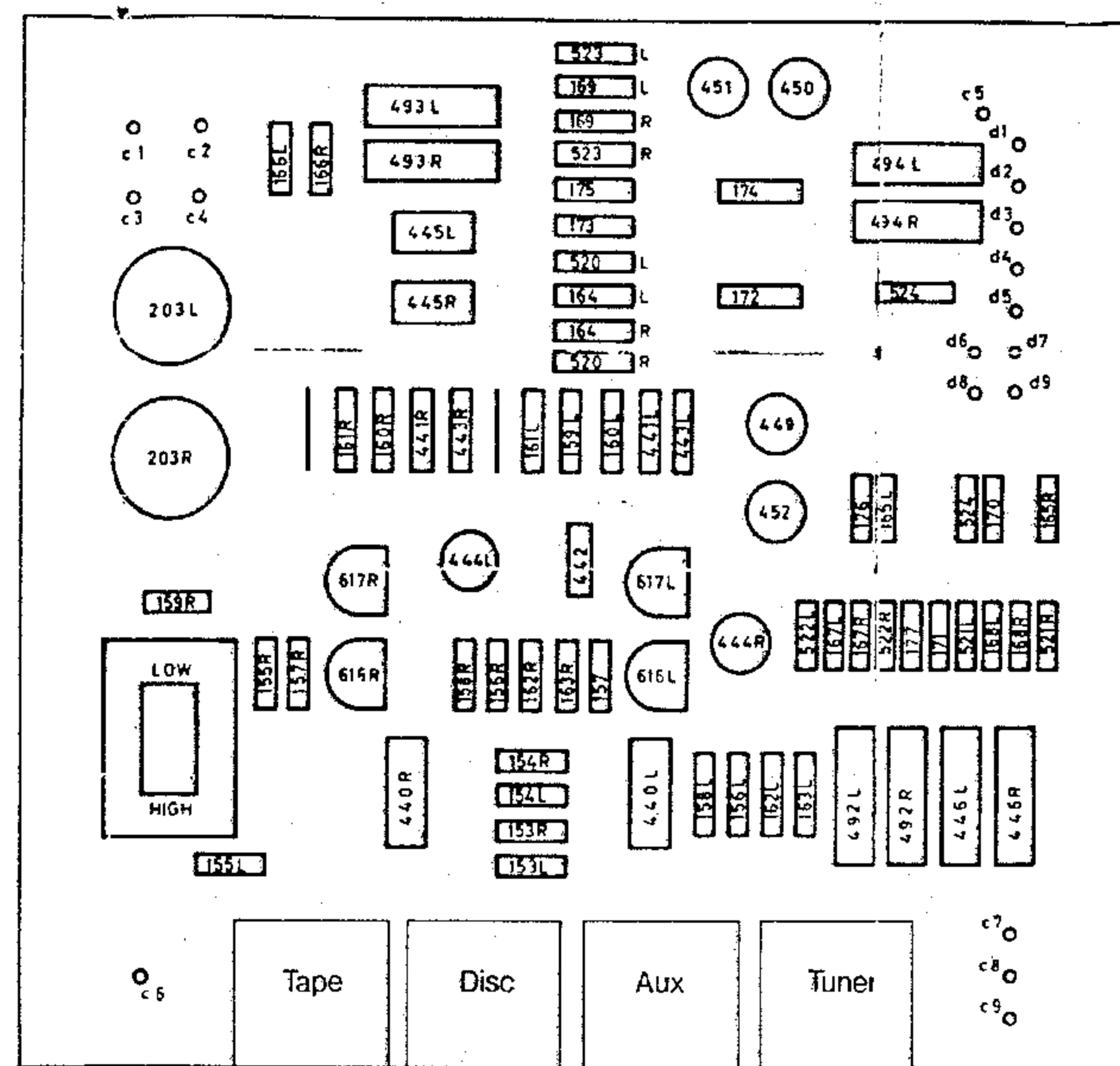

C28 Input switching and pre-amplifier

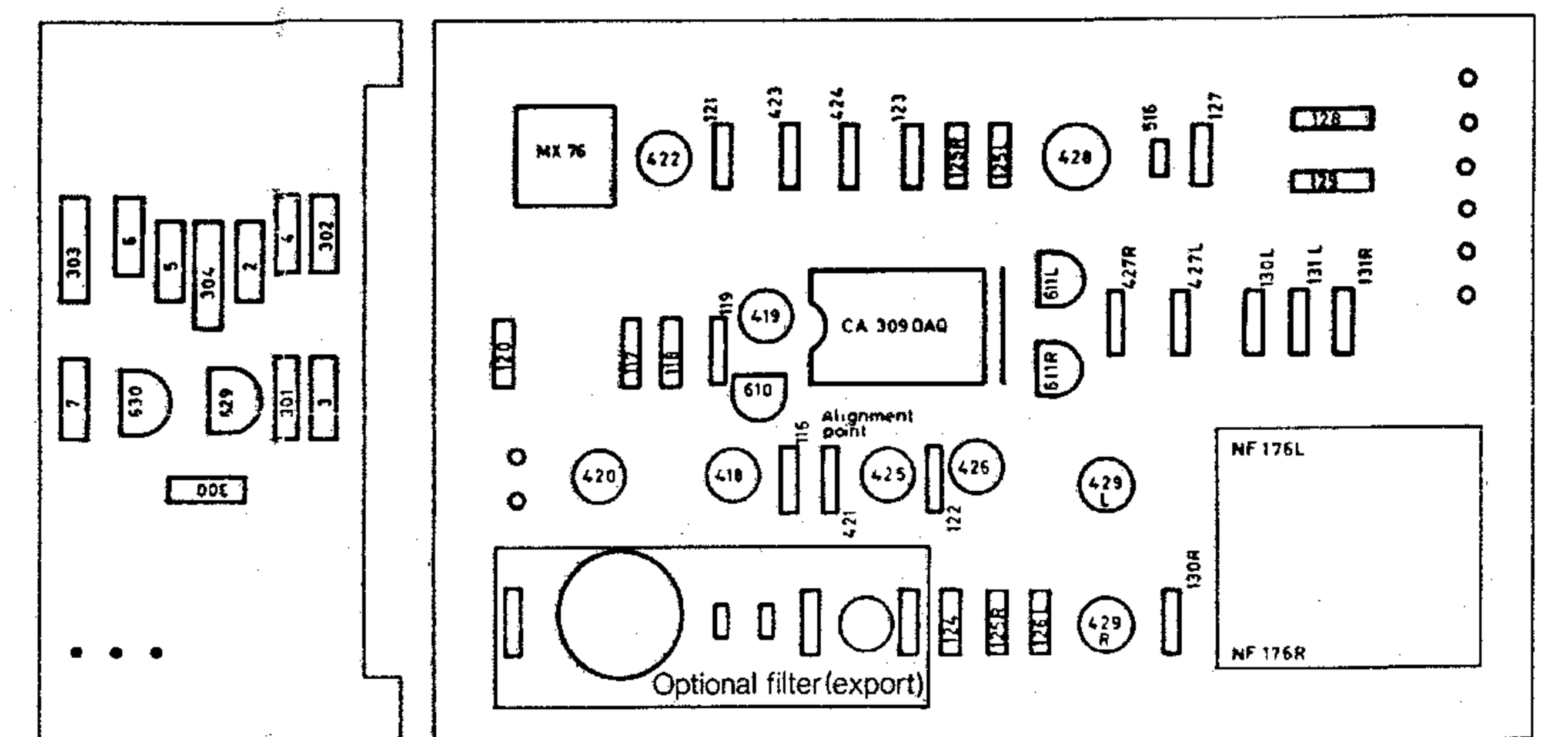

F14 A.M. aerial amplifier L14 Stereo decoder

Bottom View

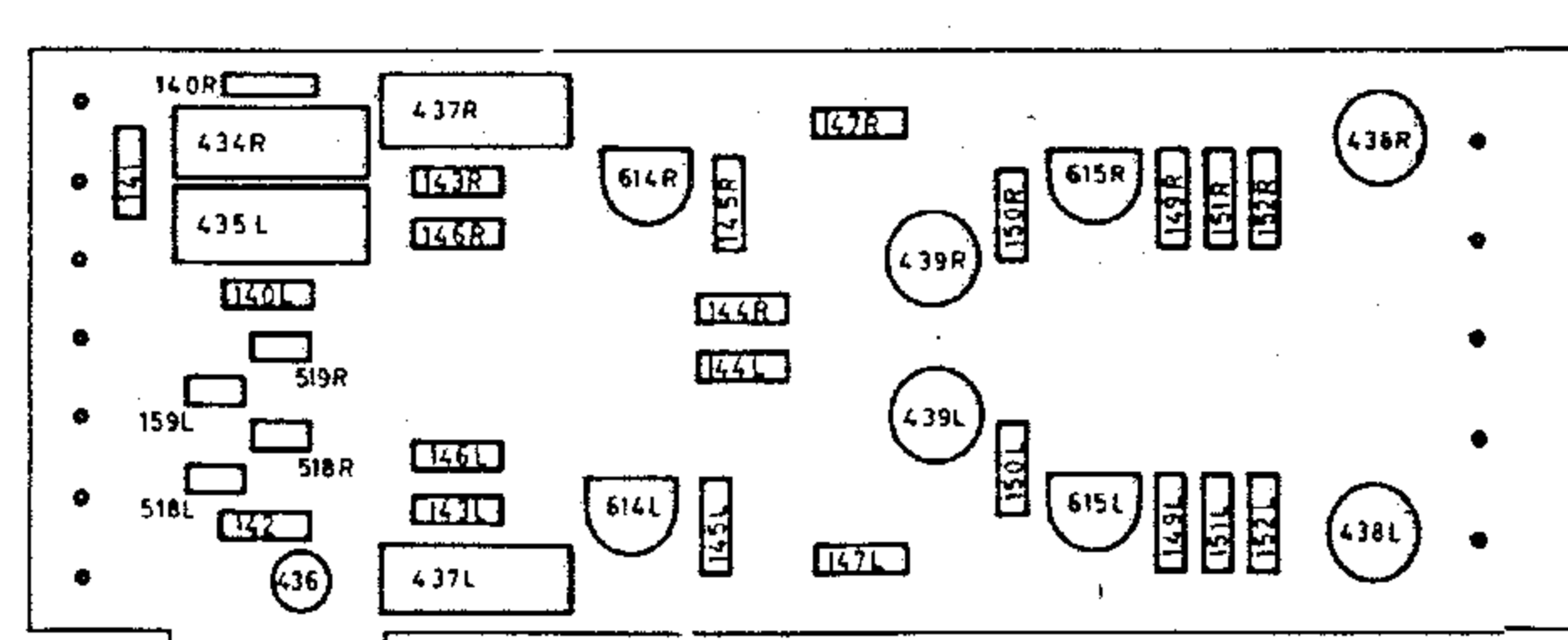

C30 Tuner power supply and audio output
Tuners Only

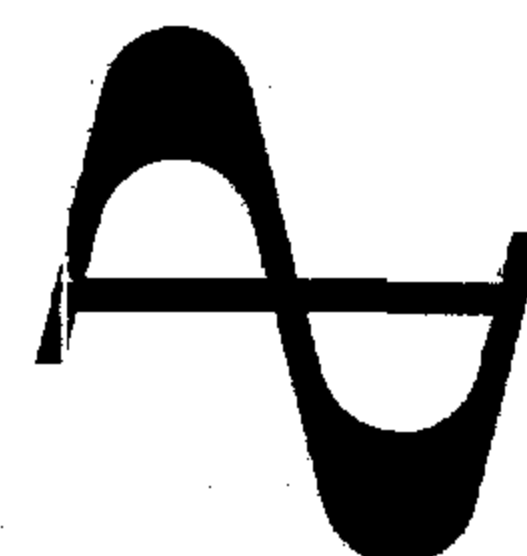

Armstrong Audio Ltd., Writers Rd., London N7 0RZ. Tel: 01-607 3213

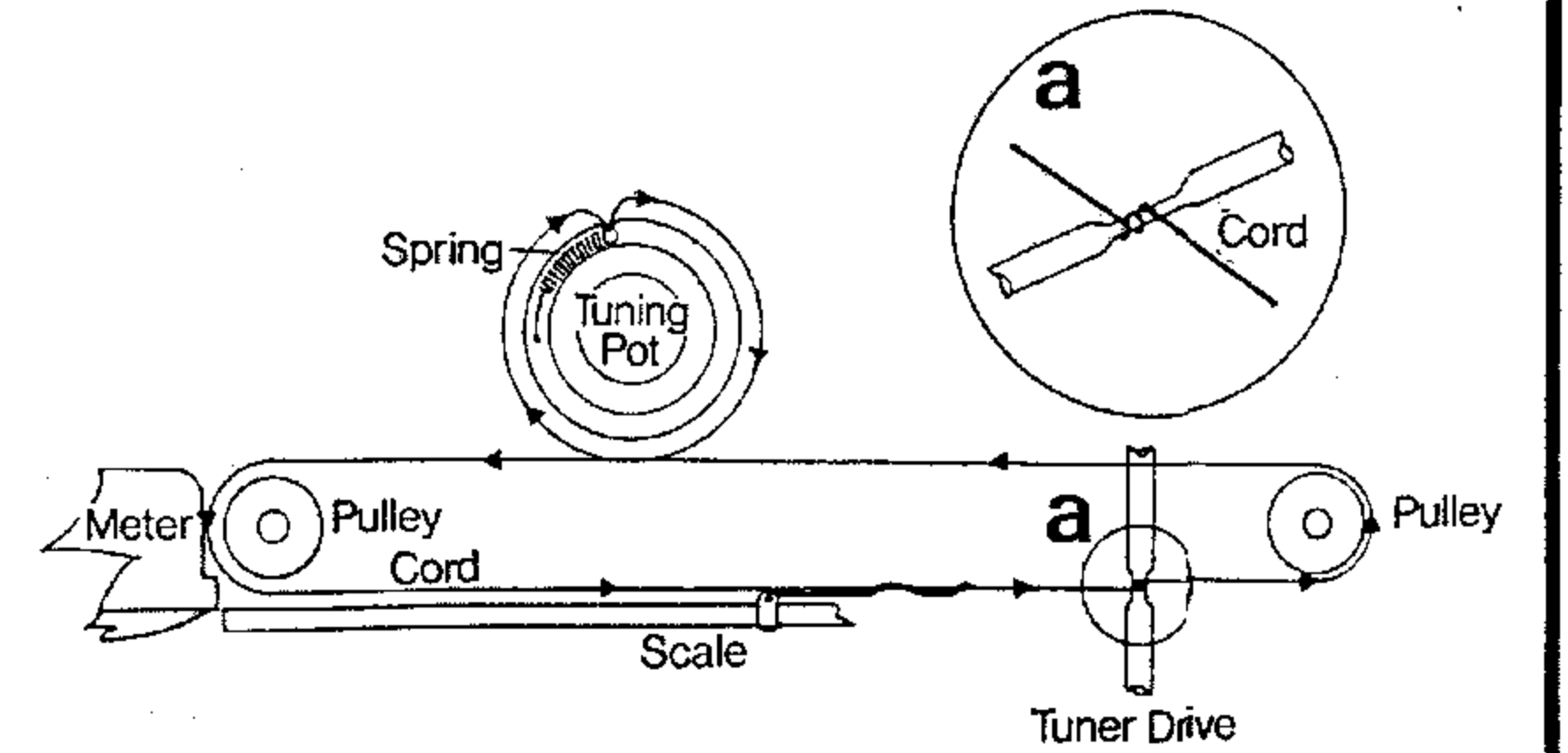

Drive Cord Replacement
Viewed from front of set (plan view)