

# Service Manual

SL-D3/K



Turntable System

## SL-D3

(XA), (XAL), (XGE), (E)

(XG), (XGF), (XGB)

## SL-D3K

(XAL), (E), (XG)

- \* The model SL-D3 (XA) is available in Asia, Latin America, Middle East and Africa only.
- \* The models SL-D3 (XAL) and SL-D3K (XAL) are available in Australia only.

- \* The model SL-D3 (XGE) is available in United Kingdom only.
- \* The models SL-D3 (E) and SL-D3K (E) are available in Scandinavia and European only.
- \* The models SL-D3 (XG) and SL-D3K (XG) are available in European only.
- \* The model SL-D3 (XGF) is available in France only.
- \* The model SL-D3 (XGB) is available in Belgium only.
- \* SL-D3 is of silver finish.
- \* SL-D3 is of black finish.

### SPECIFICATIONS

Specifications subject to change without notice.  
Weight and dimensions shown are approximate.

#### General

**Power supply:** ~110-120/220-240V, 50 or 60 Hz  
**Power consumption:** 4.5 W  
**Dimensions:** 43.0 x 13.0 x 37.5 cm  
 (W x H x D)  
 (16-59/64" x 5-7/64" x 14-49/64")  
**Weight:** 7.0 kg (15.4 lb.)

#### Turntable section

**Type:** Automatic turntable  
 Auto start  
 Auto return  
 Auto stop  
 Repeat play  
**Drive method:** Direct drive  
**Motor:** Brushless DC motor  
**Drive control method:** B·FG servo control  
**Turntable platter:** Aluminum die-cast, 31.2cm (12-9/32")

**Turntable speeds:** 33-1/3 rpm and 45 rpm  
**Pitch control:** 10% adjustment range  
**Wow and flutter:** 0.014% WRMS\*  
 0.03% WRMS (JIS C5521)  
 ±0.042% peak  
 (IEC 98A Weighted)

\*The rating refers to turntable assembly alone, excluding effects of record, cartridge or tonearm, but including platter. Measured by obtaining signal from frequency generator attached to motor assembly.

**Rumble:** -53dB(IEC 98A Unweighted)  
 -75dB(ICE 98A weighted)

#### Tonearm section

**Type:** Universal tonearm  
**Effective length:** 230 mm (9-1/16")

**Overhang:** 15 mm (19/32")  
**Friction:** Less than 7mg (lateral, vertical)  
**Effective mass:** 12g (without cartridge)  
**Tracking error angle:** Within 2°32' at the outer groove of 30cm (12") record  
 Within 0°32' at the inner groove of 30cm (12") record  
 22°

**Offset angle:**  
**Stylus pressure adjustment range:** 0-2.5 g  
**Applicable cartridge weight range:** 6-9.5 g  
 13.5-17 g (including headshell)  
**(with shellweight):** 3-6.5 g  
 10.5-14 g (including headshell)  
**Headshell weight:** 7.5 g

**Cartridge section**  
**Model No.** EPC-270C  
**Type:** Moving magnet  
**Frequency response:** 20 Hz to 25 kHz  
 20 Hz to 15 kHz ±2 dB  
**Output voltage:** 3.2 mV at 1 kHz  
 5 cm/s. zero to peak lateral velocity

**Output voltage:** [9 mV at 1 kHz 10 cm/s. zero to peak 45° velocity(DIN 45 500)]

**Channel separation:** 25 dB at 1 kHz  
**Channel balance:** Within 2 dB at 1 kHz  
**Compliance (dynamic):** 10x10<sup>-6</sup> cm/dyne at 100 Hz  
**Stylus pressure:** 1.75 ±0.25g (17.5 ±2.5mN)  
**Load impedance:** 47 kΩ to 100 kΩ  
**Weight:** 6.0 g (cartridge only)  
**Replacement stylus:** EPS-270SD

**TECHNISCHE DATEN**

Änderungen der technischen Daten vorbehalten.

Die angegebenen Gewichts- und Abmessungsdaten sind ungefähre Werte.

**Allgemeine Daten**

<b>Stromversorgung:</b>	~110-120/220-240 V, 50/60 Hz Wechselstrom
<b>Listungsaufnahme:</b>	4,5 W
<b>Abmessungen (B x H x T):</b>	43,0 x 13,0 x 37,5 cm
<b>Gewicht:</b>	7,0 kg

**Plattenspieler**

<b>Typ:</b>	Automatischer Plattenspieler Startautomatik Rückführautomatik Stopautomatik Wiederhol-Betrieb Direktantrieb
<b>Antrieb:</b>	Kollektorloser Gleichstrommotor
<b>Motor:</b>	Gegen-EMK-FG-Servo-Steuerung
<b>Antriebsregel-Methode:</b>	Aluminium-Spritzguß, 31,2cmφ
<b>Plattenteller:</b>	33-1/3 und 45 U/min
<b>Plattenteller-Drehzahlen:</b>	10% Einstellbereich
<b>Drehzahl-Feinregulierung:</b>	0,014% WRMS*
<b>Gleichlaufschwankungen:</b>	0,03% WRMS (JIS C5521) ±0,042% Spitze (IEC 98A bewertet)

\* Diese Auslegung bezieht sich auf das Laufwerk-Bauteil allein, ausschließlich Einflüsse von Schallplatte, Tonabnehmer oder Tonarm, aber einschließlich Plattenteller.  
Gemessen anhand von Signalen vom Frequenzgenerator, der an das Motorbauteil angebaut ist.

<b>Rumpel-Geräuschspannungsabstand:</b>	-53 dB (IEC 98A unbewertet)
<b>Rumpel-Fremdspannungsabstand:</b>	-75 dB (IEC 98A bewertet)

**Tonarm**

<b>Typ:</b>	Universal-Tonarm
<b>Effektive Länge:</b>	230 mm
<b>Überhang:</b>	15 mm

<b>Lagerreibung:</b>	Weniger als 7 mg (horizontal, vertikal)
<b>Effective Masse:</b>	12 g (ohne Tonabnehmer)
<b>Spurfehlwinkel:</b>	2°32' bei der Einlaufrille einer 30 cm-Platte 0°32' bei der Auslaufrille einer 30 cm-Platte
<b>Kröpfungswinkel:</b>	22°

<b>Auflagekraft-Einstellbereich:</b>	0-2,5 g
--------------------------------------	---------

<b>Zulässiger Tonabnehmer-Gewichtsbereich:</b>	6-9,5 g 13,5-17 g (einschließlich Tonarmkopf)
--	--

(mit Zusatzgewicht):

	3-6,5 g 10,5-14 g (einschließlich Tonarmkopf)
--	--

**Tonarmkopf-Gewicht:**

**Tonabnehmer**

<b>Modell-Nummer:</b>	EPC-270C
<b>Typ:</b>	Magnetischer Tonabnehmer
<b>Frequenzgang:</b>	20 Hz bis 25 kHz 20 Hz bis 15 kHz ±2 dB
<b>Ausgangsspannung:</b>	3,2 mV bei 1 kHz 5 cm/s. Null-zu-Spitze, lateral [9 mV bei 1 kHz 10 cm/s. Null-zu-Spitze, 45° (DIN 45 500)]
<b>Kanaltrennung:</b>	25 dB bei 1 kHz
<b>Kanalabweichung:</b>	Innerhalb 2 dB bei 1 kHz
<b>Nachgiebigkeit (dynamisch):</b>	10 x 10 <sup>-6</sup> cm/dyn bei 100 Hz
<b>Auflagekraft:</b>	1,75 ± 0,25 g (17,5 ± 2,5 mN)
<b>Impedanz:</b>	47 kΩ bis 100 kΩ
<b>Gewicht:</b>	6,0 g (ohne Tonarmkopf)
<b>Ersatznadel:</b>	EPS-270SD

**CAPACITRISTIQUES TECHNIQUES**

Les spécifications sont susceptibles d'être modifiées sans préavis.

**Généralités**

Les poids et les dimensions donnés sont approximatifs.

<b>Alimentation:</b>	Alternatif 110-120/220-240V, 50 ou 60 Hz
<b>Consommation:</b>	4,5 W
<b>Dimensions: (L x H x P):</b>	43,0 x 13,0 x 37,5 cm
<b>Poids:</b>	7,0 kg

**Platine de lecture**

<b>Type:</b>	Platine automatique Démarrage automatique Retour automatique Arrêt automatique Audition répétée
--------------	---

<b>Système d'entraînement:</b>	Entrainement direct
<b>Moteur:</b>	Moteur C.C. sans balai
<b>Groupe de réglage:</b>	Servocommande du générateur de fréquence de force contre-électromotrice

<b>Plateau de lecture:</b>	Aluminium moulé sous pression, 31,2 cm
----------------------------	--

<b>Vitesses de rotation:</b>	33-1/3 et 45 t/p.m
<b>Réglage d'écart:</b>	Plage de réglage de 10%
<b>Pleurage et scintillement:</b>	0,014% WRMS* 0,03% de valeur efficace (JIS C5521) ±0,042% de crête (IEC 98A Pondéré)

\* Ce régime nominal se rapporte à l'ensemble du tournedisque seul, excluant les effets du disque, de la cellule pick-up ou du bras de lecture, mais comprenant le plateau. Mesuré par l'obtention d'un signal provenant du générateur de fréquences fixé à l'assemblage du moteur.

<b>Ronflement:</b>	-53 dB (IEC 98A Non pondéré) -75 dB (IEC 98A Pondéré)
--------------------	--

**Bras de lecture**

<b>Type:</b>	Bras de lecture universel
<b>Longueur effective:</b>	230 mm
<b>Porte-à-faux:</b>	15 mm
<b>Frottement:</b>	Moins de 7 mg (latéral et vertical)

<b>Masse réelle:</b>	12 g (sans la cellule pick-up)
<b>Angle d'erreur de piste:</b>	En deçà de 2°32' au sillon extérieur d'un disque de 30 cm En deçà de 0°32' au sillon intérieur d'un disque de 30 cm
<b>Angle de décalage:</b>	22°

<b>Plage de réglage de la pression d'appui:</b>	0-2,5 g
---	---------

<b>Gamme du poids de la cellule pick-up utilisable:</b>	6-9,5 g 13,5-17 g (y compris la coque porte-cellule)
---	---

(avec contrepoids de la cellule):

	3-6,5 g 10,5-14 g (y compris la coque porte-cellule)
--	---

**Poids de la cellule:**

**Cellule pick-up**

<b>No. du modèle:</b>	EPC-270C
<b>Type:</b>	Aliment mobile
<b>Réponse en fréquence:</b>	20 Hz à 25 kHz 20 Hz à 15 kHz ±2 dB 3,2 mV à 1 kHz; 5 cm/s., zéro à vitesse latérale de crête (9 mV à 1 kHz 10 cm/s., zéro à vitesse 45° de crête [DIN 45 500])
<b>Tension de sortie:</b>	25 dB à 1 kHz En deçà de 2 dB à 1 kHz
<b>Séparation de canal:</b>	10 x 10 <sup>-6</sup> cm/dyne à 100 Hz
<b>Equilibrage des canaux:</b>	
<b>Elasticité (dynamique):</b>	
<b>Pression de la pointe de lecture:</b>	1,75 ± 0,25 gramme (17,5 ± 2,5 mN)

<b>Impédance de charge:</b>	47 kΩ to 100 kΩ
<b>Poids:</b>	6,0 grammes (cellule seule)

<b>Pointe de lecture de remplacement:</b>	EPS-270SD
---	-----------

■ **CONTENTS**

PARTS IDENTIFICATIONS.....	3	TERMINAL GUIDE OF TRANSISTOR & IC.....	11
FEATURES .....	3	SCHEMATIC DIAGRAM .....	11 ~ 12
HOW TO OPERATE .....	4	PRINTED CIRCUIT BOARD .....	13 ~ 14
DISASSEMBLY PROCEDURE.....	5	EXPLODED VIEWS .....	15 ~ 17
ADJUSTMENTS .....	6 ~ 8	PARTS ARRANGEMENT DIAGRAM .....	18
DIAL DRIVE MECHANISM DIAGRAM.....	9	REPLACEMENT PARTS LIST .....	19 ~ 20
BLOCK DIAGRAM .....	10		

■ **PARTS IDENTIFICATIONS**

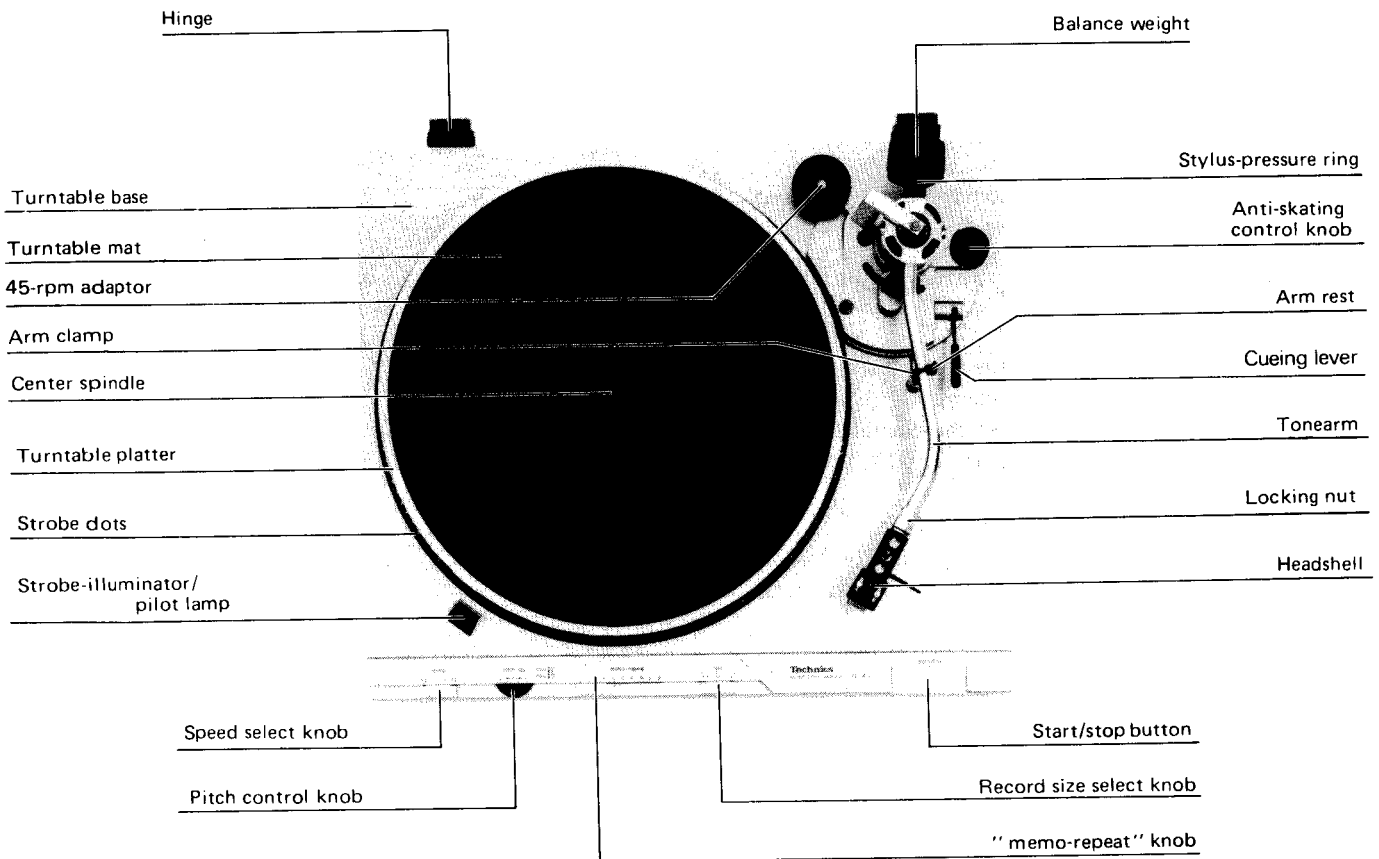

■ **FEATURES**

- Front panel controls provide exceptional convenience
- Integral rotor/platter structure for stable rotation
- "TNRC"\* base material provides an acoustic shield  
"TNRC" . . . . Technics Non-Resonance Compound
- Low-mass, low-friction gimbal suspension tonearm
- Pitch control with illuminated stroboscope
- Viscous-damped cueing
- Anti-skating control
- Hinged, detachable dust cover
- Automatic tonearm return
- Auto-start, auto-stop, auto-return and programmable repeat play make the SL-D3 a pleasure to use.

## ■ HOW TO OPERATE

### Manual play of a record

1. Place a record on the turntable mat.
2. Set the speed select knob to the desired record speed. (See Fig. 1.)
3. Remove the stylus protector, if your cartridge has a detachable one.
4. Release the arm clamp.
5. Set the cueing lever to the up position. (See Fig. 2.)
6. Move the tonearm over the desired groove. The strobe-illuminator/pilot lamp will light up and the turntable platter will start rotating.

7. Set the cueing lever to the down position. (See Fig. 3.) The tonearm will descend slowly onto the record and play will begin.

8. When play is finished, the tonearm will automatically return to the arm rest (auto-return), and the turntable platter will stop rotation.

If the unit is not to be used for some time, set the speed select knob to the neutral "•" position.

Attach the stylus protector again, if you have one, to guard the stylus tip from damage.

### Automatic play

1. Set the speed select knob in the same manner as in manual play and release the arm clamp.
2. Set the record size select knob to the diameter of the record (7" [17 cm], 10" [25 cm], or 12" [30 cm]) you wish to play. (See Fig. 4.)
3. Push the start/stop button. (See Fig. 5.) The tonearm will move automatically over the lead-in groove and descend slowly onto the record (auto-start). Play will begin.
4. When play has finished, the tonearm will automatically return to the arm rest (auto-return).

### Repeat play of a record

1. Set the "memo-repeat" knob to the desired number of times you wish to play. (See Fig. 6.) "R" position enables you to repeat play continuously.

#### Note:

The "memo-repeat" knob may be turned either clockwise or counterclockwise, except during automatic start or automatic return cycle.

2. Start play in the same way as for automatic play.

### How to stop play

Push the start/stop button.

The tonearm automatically returns to the arm rest, and the turntable stops rotating.

### How to suspend play

Set the cueing lever to the up position.

The stylus tip of the cartridge will be lifted from the record.

### When you play a 45-rpm record with a large center hole

Place the 45-rpm adaptor on the center spindle. Set the speed select knob to the "45" position.

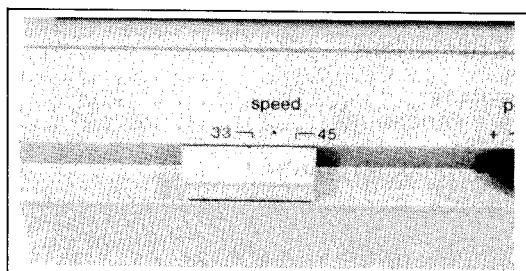

Fig. 1

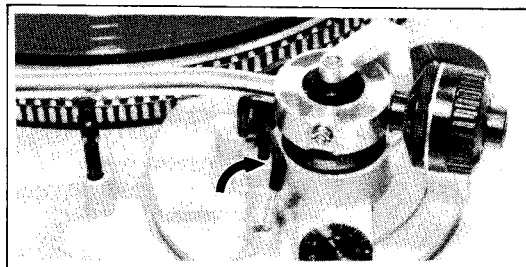

Fig. 2

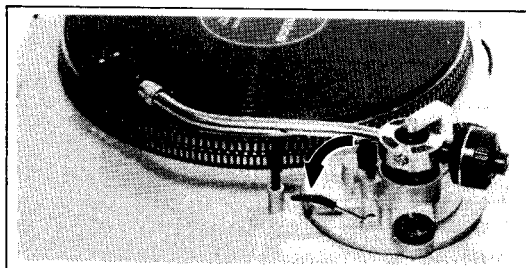

Fig. 3

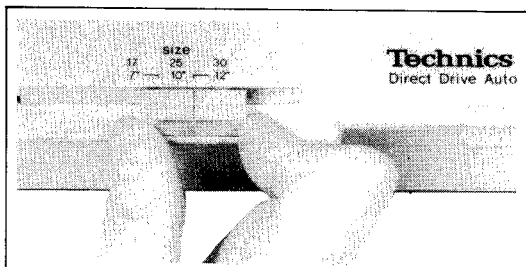

Fig. 4

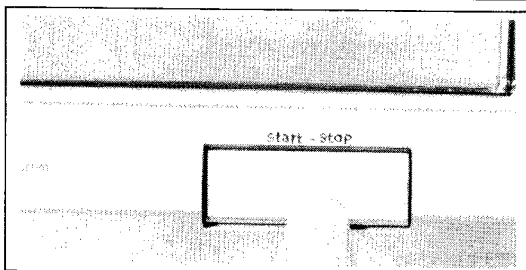

Fig. 5

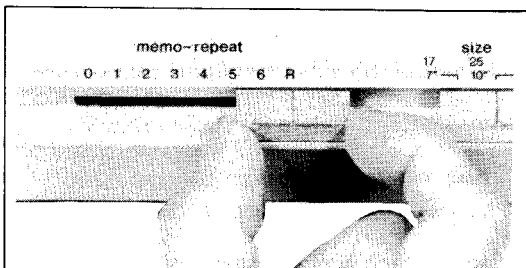

Fig. 6

## ■ DISASSEMBLY PROCEDURE

### How to remove the bottom plate (See Fig. 7.)

- 1) Remove the head shell and turntable.
- 2) Secure the tone arm with the arm clasper.
- 3) Turn over the set taking care not to damage the dust cover.
- 4) Remove the 7 bottom plate setscrews **A**.

**Note)** Be careful not to lose the boss cap attached to the insulator on the cabinet side.

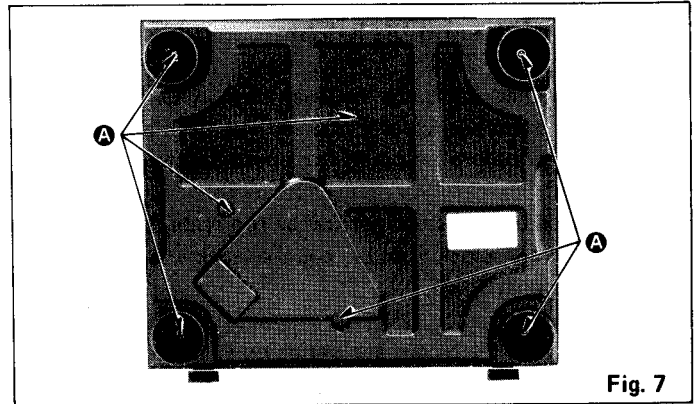

Fig. 7

### How to remove the radiating fin (See Fig. 8.)

- 1) Remove the bottom board as explained above.
- 2) Remove the 4 setscrews **B** of the radiating fin.
- 3) Remove the 2 setscrews **C** of the top radiating fin.

### Removal of drive P.C.B. and automatic mechanism ass'y (See Fig. 8.)

- 1) Remove the bottom board.
- 2) Remove the speed change knob.
- 3) Remove the 4 setscrews **D** of the automatic mechanism ass'y.
- 4) Remove the 4 setscrews **E** of the drive P.C.B..
- 5) Pull out the boards in the direction of the arrow **1** as illustrated.

**Note)** 1. Pull the start plate in the direction of the arrow **2** because it may otherwise come in touch with the tone arm fixing plate ass'y.  
 2. Since the neon cover is fixed being in contact with the drive P.C.B. take care not to lose the neon cover when removing the base plate.

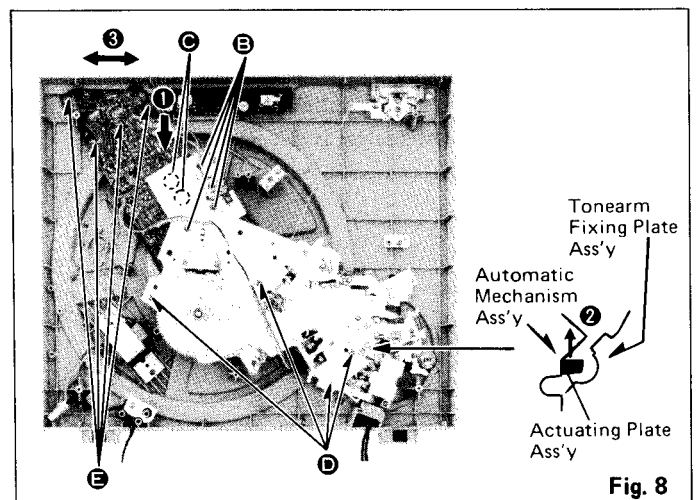

Fig. 8

### Removal of stator coil (See Fig. 9.)

- 1) Remove the 3 setscrews of the stator cover of the removed drive P.C.B..
- 2) Disconnect the 18 soldered parts of the stator coil.
- 3) Remove the 3 setscrews **F** of the stator coil and P.C.B. board.

Then, the stator coil can be removed. When installing, position the stator coil as shown by the arrow **4**.

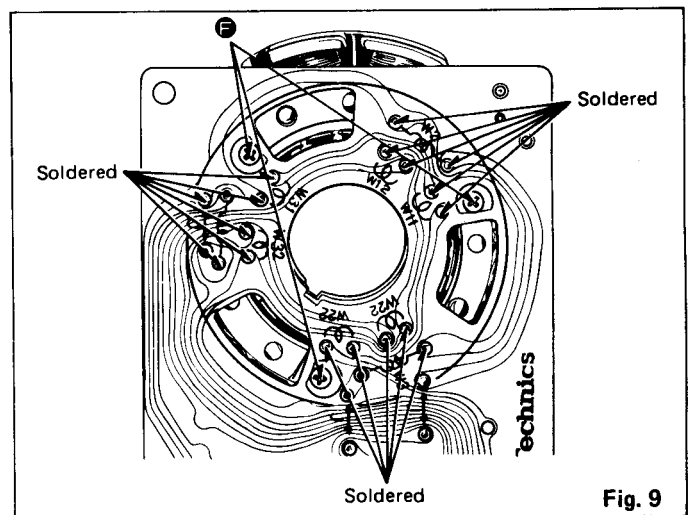

Fig. 9

### Precautions for assembly

**Note)** When assembling the mechanical and drive P.C.B., follow the procedure below. (See Fig. 13.)

- 1) Temporarily secure the 3 setscrews of the stator coil.
- 2) Secure the automatic mechanism ass'y with 4 setscrews. (Pull the actuating plate ass'y in the direction of the arrow 2 or otherwise it may touch the tone arm fixing plate ass'y.)
- 3) There is some clearance between the drive P.C.B. and automatic mechanism ass'y in the direction of the arrow 3. Find a position where the pitch control knob doesn't touch the cabinet, and then install the drive base plate with 4 setscrews.

## ■ ADJUSTMENTS

### Adjustment of the arm-lift height (See Figs. 10 and 11.)

The arm-lift height (distance between the stylus tip and record surface when cueing lever is raised) has been adjusted at the factory before shipping to approximately 5 to 10 mm.

If the clearance becomes too narrow or too wide, turn the adjustment screw clockwise or counterclockwise, while pushing the arm lift down.

#### Clockwise rotation

—distance between the record and stylus tip is decreased.

#### Counterclockwise rotation

—distance between the record and stylus tip is increased.

#### Note:

As the adjusting screw has a hexagonal head, be sure to make the adjustment while depressing the arm lift, or the screw will not move freely.

Also be sure that the hexagonal head retracts correctly into the arm lift when the latter is released.

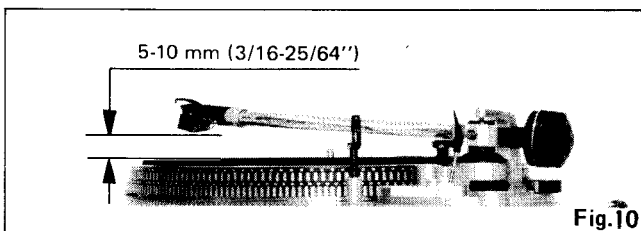

Fig. 10

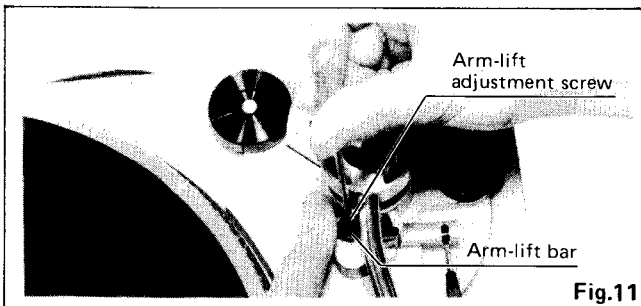

Fig. 11

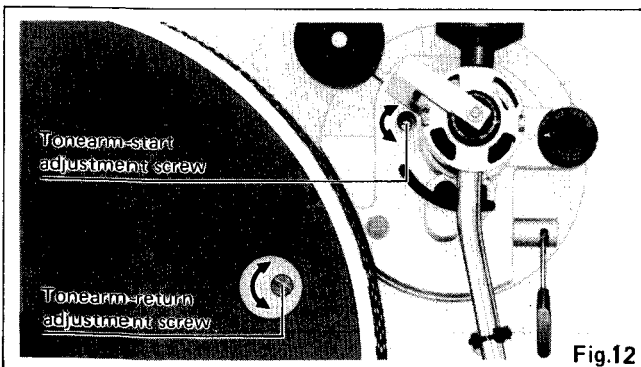

Fig. 12

### Adjustment for automatic start position (See Fig. 12.) (Remove the rubber cap.)

In cases where the stylus tip sets down outside of the record.

—rotate clockwise.

In cases where the stylus tip sets down too far in the recorded groove

—rotate counterclockwise.

### Adjustment for automatic return position (See Fig. 12.)

(Remove the turntable mat.)

In cases where the tonearm tends to return before the playing has finished.

—rotate clockwise

In cases where the tonearm fails to return after the last groove of the record has been played.

—rotate counterclockwise

### Speed adjustment (with pitch-control knob) (See Fig. 13.)

Strobe dots are set on the rim of the turntable platter according to the power-line frequency and the speed of the records. Make adjustment, referring to the strobe-dot indication.

1. Set the speed select knob to the speed to be adjusted.
2. Release the arm clamp and move the tonearm toward the record.

The strobe-illuminator/pilot lamp will light up and the turntable platter will rotate.

3. While turning the pitch-control knob either to the "+" side or "-" side, adjust so that the strobe dots of the turntable platter look as if they were stationary. This represents the correct speed.

#### "+" direction

The speed of the turntable platter will increase. Turn the knob in this direction if the strobe dots seem to be "falling back", i.e. seem to be moving counterclockwise. When the dots appear to be stationary, turntable speed is accurate.

#### "-" direction

The speed of the turntable platter will decrease. Turn the knob in this direction if the dots seem to be "running ahead", i.e. seem to be moving clockwise, until they appear stationary.

Moreover, the speed fine control knob can be used for both 33-1/3 rpm and 45 rpm.

Adjustment is to be made according to the selected speed (33-1/3 rpm or 45 rpm).

#### Note:

##### Strobe dot pattern

The strobe-illuminator/pilot lamp of this unit employs the standard commercial power source. The frequency of such power source, when actually measured, has a fluctuation of about 0.2%.

As such a fluctuation of the power source affects the strobe illuminator, the strobe dot pattern also seems to fluctuate to a certain extent. But the unit is not affected by these fluctuations of the power source, since a DC motor is employed.

In other words, rotation of the platter will be constant, and slight shifts in the movement of the dots simply reflect normal drift in the power-source frequency.

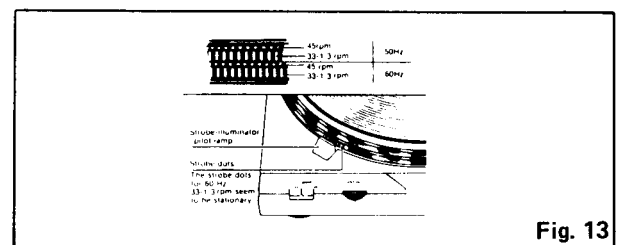

Fig. 13

## ■ JUSTIERUNGEN

### Justierung der Tonarmlifthöhe (Vgl. Abb. 10 und 11.)

Die Tonarmlifthöhe, d.h. der Abstand zwischen Nadelspitze und Schallplattenoberfläche, wenn der Lift-Hebel angehoben ist, ist werkseitig auf ungefähr 10 mm eingestellt worden.

Falls der Abstand zu groß oder zu klein wird, drehen Sie die Justierschraube im Uhrzeigersinn oder Gegenuhrzeigersinn während Sie die Tonarmliffführung nach unten drücken.

#### Drehung im Uhrzeigersinn

–Der Abstand wird kleiner.

#### Drehung im Gegenuhrzeigersinn

–Der Abstand wird größer.

#### Anmerkung:

Da die Justierschraube einen Sechskantkopf hat, muß die Tonarmliffführung während des Justierens unbedingt gedrückt gehalten werden, damit sich die Schraube leicht drehen läßt.

Vergewissern Sie sich, daß der Sechskantkopf in die Tonarmliffführung zurückkehrt, wenn diese losgelassen wird.

### Justierung des Tonarmaufsetzpunktes der Automatik (Vgl. Abb. 12.)

(Die Gummikappe abnehmen)

Falls der Aufsetzpunkt außerhalb der Platte liegt.

–Im Uhrzeigersinn drehen.

Falls der Aufsetzpunkt im Wiedergabeteil der Schallplatte liegt.

–Im Gegenuhrzeigersinn drehen.

### Justierung des Abschaltpunktes der Automatik (Vgl. Abb. 12.)

(Die Plattentellerauflage abnehmen.)

Falls der Tonarm zu früh zurückkehrt.

–Im Uhrzeigersinn drehen.

Falls der Tonarm nach Erreichen der Auslaufrille nicht zurückkehrt.

–Im Gegenuhrzeigersinn drehen.

### Drehzahl-Feineinstellung (mit dem Drehzahl-Feineinsteller) (Vgl. Abb. 13.)

Die Stroboskoppunkte sind auf dem Plattentellerrand entsprechend der Stromfrequenz und der Drehzahl der Schallplatten angebracht.

Richten Sie sich bei der Drehzahl-Feineinstellung nach dem Stroboskopbild.

1. Stellen Sie den Drehzahl-Wahlschieber auf die zu regulierende Drehzahl ein.
2. Lösen Sie die Tonarm-Arretierklammer, und schwenken Sie den Tonarm zur Schallplatte.  
Die Stroboskoplampe/Einschaltkontrolle leuchtet auf, und der Plattenteller dreht sich.
3. Regulieren Sie durch Drehen des Einstellknopfes in "+" oder "-" Richtung solange, bis die Stroboskoppunkte den Anschein vermitteln, daß sie stillstehen. Dieser Zustand stellt die korrekte Drehzahl dar.

#### "+" Richtung

Die Drehzahl des Plattentellers erhöht sich. Drehen Sie den Knopf in diese Richtung, wenn die Stroboskoppunkte "zurückzufallen", d.h. im Gegenuhrzeigersinn zu fließen scheinen. Wenn die Punkte stillzustehen scheinen, ist die Geschwindigkeit korrekt.

#### "-" Richtung

Die Drehzahl des Plattentellers verringert sich. Drehen Sie den Knopf in diese Richtung, wenn die Stroboskoppunkte "vorauszufließen", d.h. im Uhrzeigersinn zu fließen scheinen. Regulieren Sie, bis sie stillzustehen scheinen.

#### Anmerkung:

#### Stroboskoppunktemuster

Die Stroboskoplampe/Kontrolllampe dieses Gerätes arbeitet mit normalem Netzstrom. Die Netzfrequenzschwankungen liegen in einem Bereich von ungefähr  $\pm 0.2\%$ .

Da eine solche Netzschwankung die Stroboskoplampe beeinflusst, scheint das Punktemuster auch zu einem gewissen Grad zu fließen. Die Drehzahl des Plattentellers wird jedoch durch diese Schwankung nicht beeinflusst, da ein Gleichstrommotor den Plattenteller antreibt. Anders ausgedrückt, die Umdrehungsgeschwindigkeit des Plattentellers bleibt konstant, und die geringfügige Bewegung der Stroboskoppunkte entspricht lediglich der normalen Schwankung der Netzfrequenz.

### Einstellung der Drehzahl (vgl. Eig. 14)

Falls die Drehzahl durch Auswechseln von IC oder anderen Teilen sowie durch Drehen des Knopfes für Drehzahlfeinverstellung (VR3) sich nicht richtig einstellen läßt, die Nacheinstellung gemäß dem folgenden Verfahren vornehmen.

1. Den Knopf für Drehzahlfeinverstellung auf die Mitte stellen.
2. In Betriebsart 33-1/3 U/min VR1 (33) so drehen, daß die Drehzahl an Hand des Stroboskops auf den vorgeschriebenen Punkt eingestellt wird.
3. Anschließend in Betriebsart 45 U/min VR2 (45) so drehen, daß die Drehzahl an Hand des Stroboskops auf den vorgeschriebenen Punkt eingestellt wird.
4. Nach der Einstellung den Drehzahlwechschalter umstellen und sich vertewissern, daß die Drehzahlen in den Betriebsarten von 33-1/3 und 45 U/min mit der jeweils vorgeschriebenen übereinstimmt.

#### Anmerkung:

Für die o.g. Einstellung erfolgt das Demontageverfahren. Die Bodenplatte entfernen und das Gerät zur Reparatur auf einen Tisch setzen, um Zugang von unten her zu gewinnen.

Es ist auch möglich, nur durch Entfernen der Drehscheibe das Gerät einzustellen.

Die Drehscheibe wie unten dargestellt entfernen, und durch das dann erscheinende Loch läßt sich ein Schraubenzieher einstecken, um VR1 und VR2 zu drehen.

## ■ REGLAGES

### Mise au point de la hauteur de l'élevateur du bras (Voir Figs. 10 et 11.)

La hauteur de l'élevateur du bras (distance entre l'extrémité de la pointe de lecture et la surface du disque lorsque le levier de relevage du bras est soulevé) a été réglée en usine avant son départ sur une valeur approximative de 10 mm. Si l'écartement devient trop étroit ou trop large, tourner la vis de réglage dans le sens des aiguilles d'une montre ou en sens inverse, tout en abaissant l'élevateur du bras.

#### Rotation dans le sens des aiguilles d'une montre.

—La distance entre la surface du disque et l'extrémité de la pointe de lecture diminue.

#### Rotation dans le sens contraire des aiguilles d'une montre.

—La distance entre la surface du disque et l'extrémité de la pointe de lecture augmente.

#### Nota:

Comme la vis de réglage possède une tête hexagonale, s'assurer d'effectuer la mise au point tout en abaissant l'élevateur du bras, sinon la vis ne bougera pas librement. Vérifier aussi que la tête hexagonale se retire correctement dans l'élevateur du bras quand ce dernier est libéré.

### Mise au point pour une position de marche automatique. (Voir Fig. 12.)

(Retirer le capuchon en caoutchouc.)

Dans le cas où la tête de la pointe de lecture s'abaisse en dehors du disque.

#### —Déplacer dans le sens des aiguilles d'une montre.

Dans le cas où la tête de la pointe de lecture s'abaisse trop loin du sillon enregistré.

#### —Déplacer dans le sens contraire des aiguilles d'une montre.

### Mise au point pour une position de retour automatique (Voir Fig. 12.)

(Retirer le tapis du plateau de lecture.)

Dans le cas où le bras de lecture tend à revenir avant que l'audition ne soit terminée.

#### —Déplacer dans le sens des aiguilles d'une montre.

Dans le cas où le bras de lecture ne peut revenir en arrière après que le dernier sillon du disque ait été joué.

#### —Déplacer dans le sens contraire des aiguilles d'une montre.

### Réglage de la vitesse (avec la manette de réglage de précision) (Voir Fig. 13.)

Les points du stroboscope sont réglés sur le bord du plateau du tourne-disque en fonction de la fréquence de réseau et de la vitesse des disques.

Il faut effectuer le réglage de la vitesse en se référant aux indications des points du stroboscope.

1. Régler la manette sélectrice de vitesse sur la vitesse devant être mise au point.
2. Libérer le clip de retenue du bras et déplacer le bras de lecture vers le disque.

La lampe-témoin/illuminomètre stroboscopique s'éclairera et le plateau commencera à tourner.

3. Tout en tournant la manette de réglage de précision

suffisamment, soit dans le sens "+" soit dans le sens "-", ajuster de façon à ce que les points du stroboscope du plateau paraissent stationnaires.

Cet état représente la vitesse correcte.

#### Sens "+"

La vitesse du plateau augmentera. Tourner la manette dans cette direction si les points stroboscopiques semblent "reculer", c.-à-d. se déplacer dans le sens inverse des aiguilles d'une montre. Lorsque les points paraissent immobiles, la vitesse du plateau est exacte.

#### Sens "-"

La vitesse du plateau diminuera. Tourner la manette dans cette direction si les points stroboscopiques semblent "s'écouler vers l'avant", c.-à-d. se déplacer dans le sens des aiguilles d'une montre, jusqu'à ce qu'ils paraissent stationnaires.

#### Nota:

#### Image des points stroboscopiques.

La lampe-témoin/illuminomètre stroboscopique de cet appareil utilise une alimentation commerciale standard. La fréquence d'une pareille source d'énergie, lorsqu'elle est effectivement mesurée, montre une variation d'à peu près 0.2%.

Comme une telle variation de la source d'énergie affecte l'illuminomètre stroboscopique, l'image des points stroboscopiques semble varier aussi sur une certaine étendue. Mais l'appareil n'est pas affecté par ces variations de la source d'énergie, étant donné qu'un moteur à courant continu est utilisé.

En d'autres mots, la rotation du plateau restera constante et les légers déplacements dans le mouvement des points ne reflètent simplement qu'une déviation normale dans la fréquence de la source d'énergie.

### Réglage de la vitesse (Voir la Fig. 14.)

Si la vitesse de rotation ne peut pas être correctement réglée par le remplacement du C.I. ou d'autres éléments et en tournant le bouton (VR3) de réglage fin de la vitesse, refaire le réglage en suivant le procédé suivant.

1. Placer le bouton de réglage fin de la vitesse, sur la position centrale.
2. Dans le mode 33-1/3 t/pm, tourner le VR1 (33) de telle sorte que la vitesse soit réglée sur le point spécifié par l'utilisation du stroboscope.
3. Puis, dans le mode 45 tours, tourner le VR2 (45) de telle sorte que la vitesse soit réglée sur la point spécifié, par l'utilisation du stroboscope.
4. Après ce réglage, déplacer le commutateur de changement de vitesse et s'assurer que les vitesses sont celles qui ont été spécifiées dans les modes 33-1/3 et 45 tours.

#### Note:

Pour les réglages suivants, suivre les procédés de dépose. Pour les travaux de réparation, enlever la plaque de base et placer l'appareil sur une table et accéder à l'appareil par dessous.

Il est aussi possible de régler l'appareil après avoir seulement enlevé son tourne-disques.

Enlever le tourne-disques comme le montre l'illustration ci-dessous, puis un orifice apparaîtra par lequel un tournevis peut être introduit pour tourner les VR1 et VR2.



## ADJUSTMENT PROCEDURE

### Adjustment of Speed (See Fig. 14.)

If the number of revolutions cannot be correctly adjusted by replacing IC or other parts and turning the fine speed adjusting knob (VR3), make the re-adjustment according to the following procedure.

Set the fine speed adjusting knob to the central position. In 33-1/3 r.p.m. mode, turn VR1 (33) so that the speed is adjusted to the specified point by using a stroboscope. Next, in 45 r.p.m. mode, turn VR2 (45) so that the speed is adjusted to the specified point by using a stroboscope.

After the adjustment, shift the speed change switch and make sure that the speeds in 33-1/3 r.p.m. and 45 r.p.m. modes are as specified.

**Note:**

For the above adjustments, follow the disassembly procedure. Remove the bottom plate and put the set on a table for repair work and gain access to it from underneath.

It is also possible to adjust the set only with its turntable removed.

Remove the turntable as illustrated below, then a hole will be revealed from which a screwdriver can be inserted to turn VR1 and VR2.

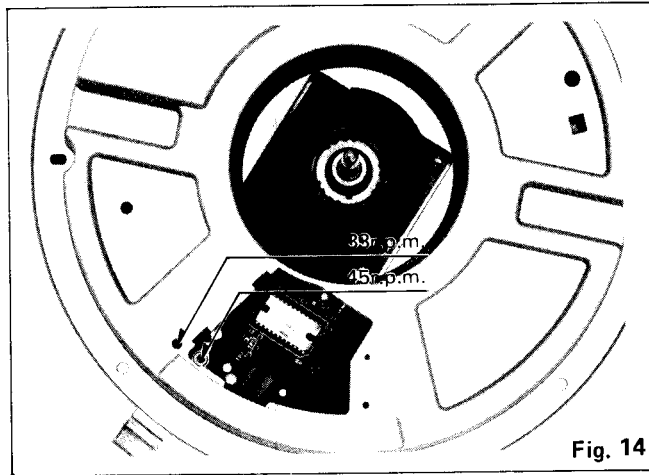
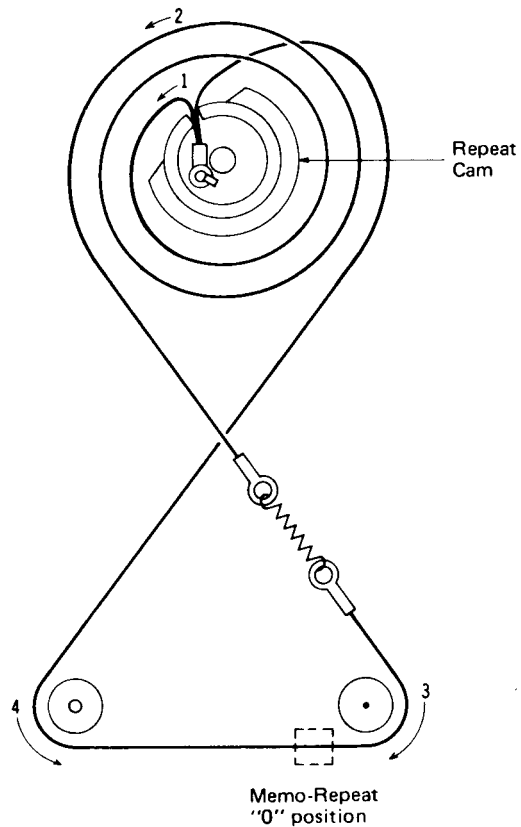
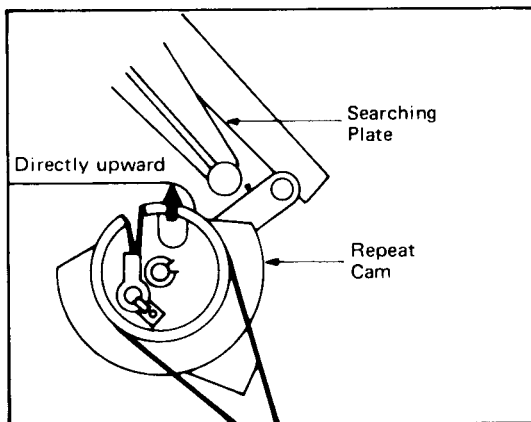

Fig. 14

## DIAL DRIVE MECHANISM DIAGRAM



Adjust the cord according to following procedure.

Link the hook of the cord onto the projection of the cam.

Hold the spring-attached side of the cord with the right hand, and wind it around the repeat cam twice, and then set the cord in accordance with steps 1 – 4.

Adjust so that the repeat cam and searching plate are positioned as illustrated. Set the memo-repeat knob to the "0" position and secure it there.

10 ■ BLOCK DIAGRAM

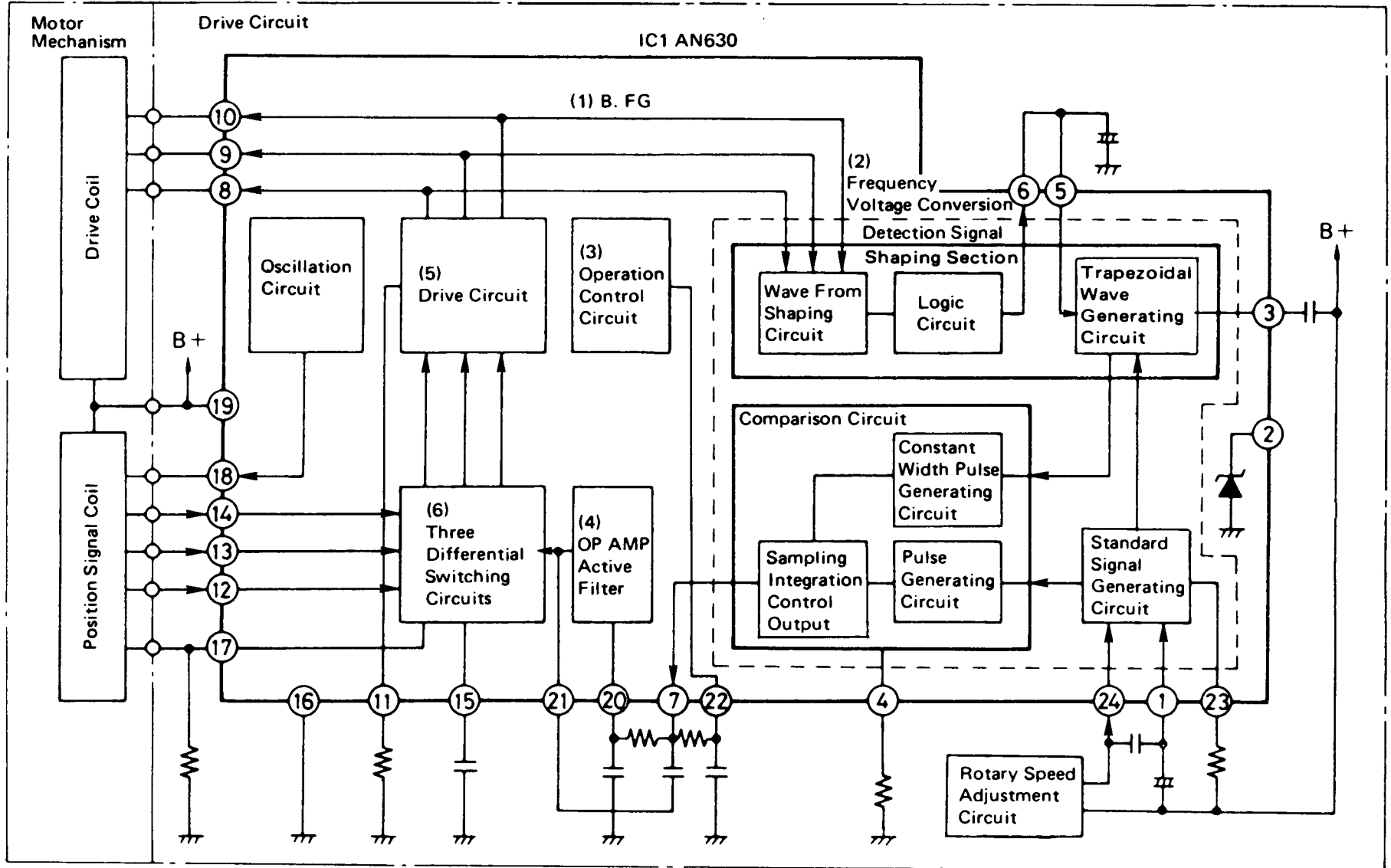

# Schematic Diagram (This schematic diagram may be modified at any time with the development of new technology.)

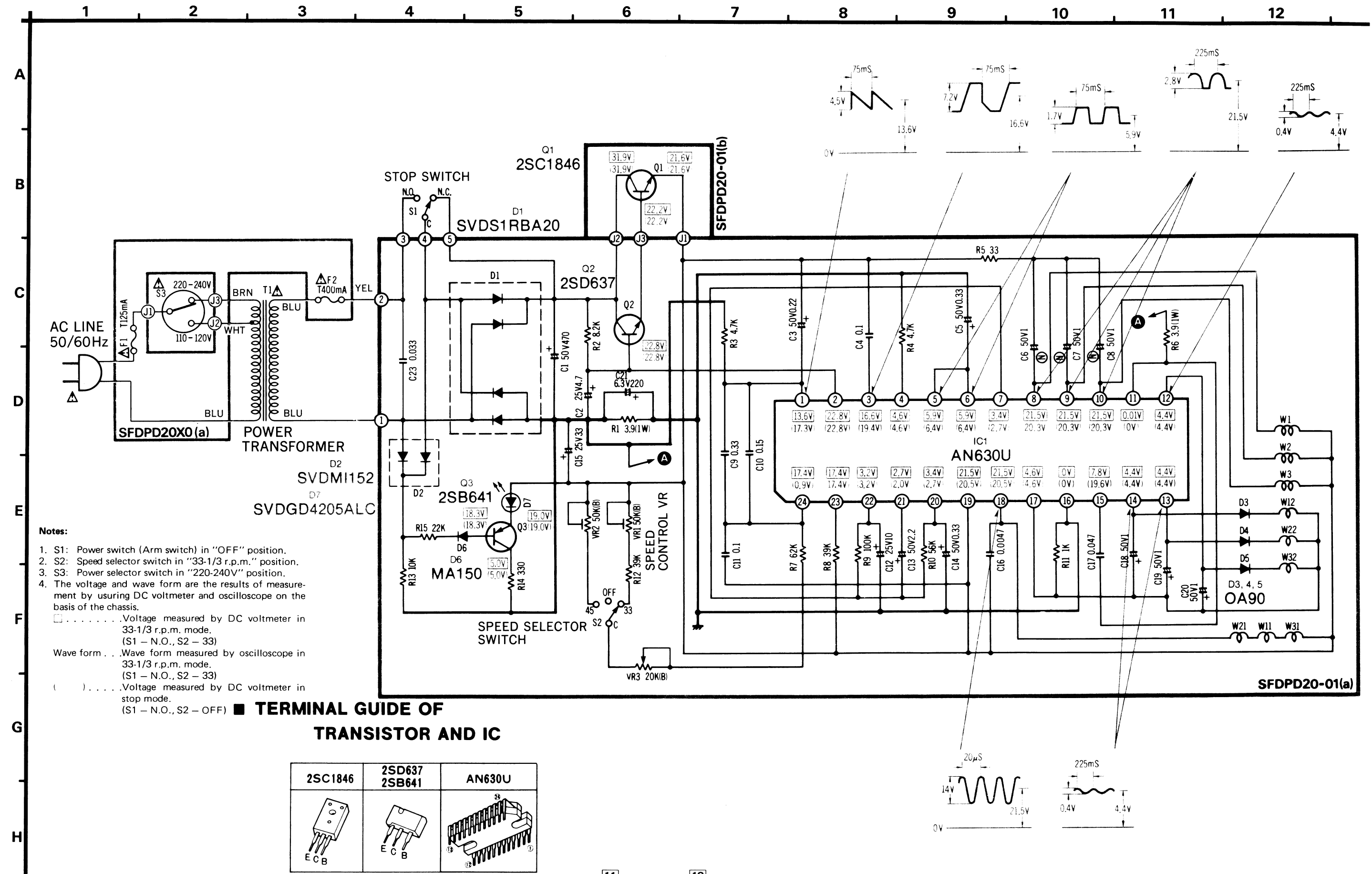

# Printed Circuit Board

Earth (Ground) lines  
 B lines

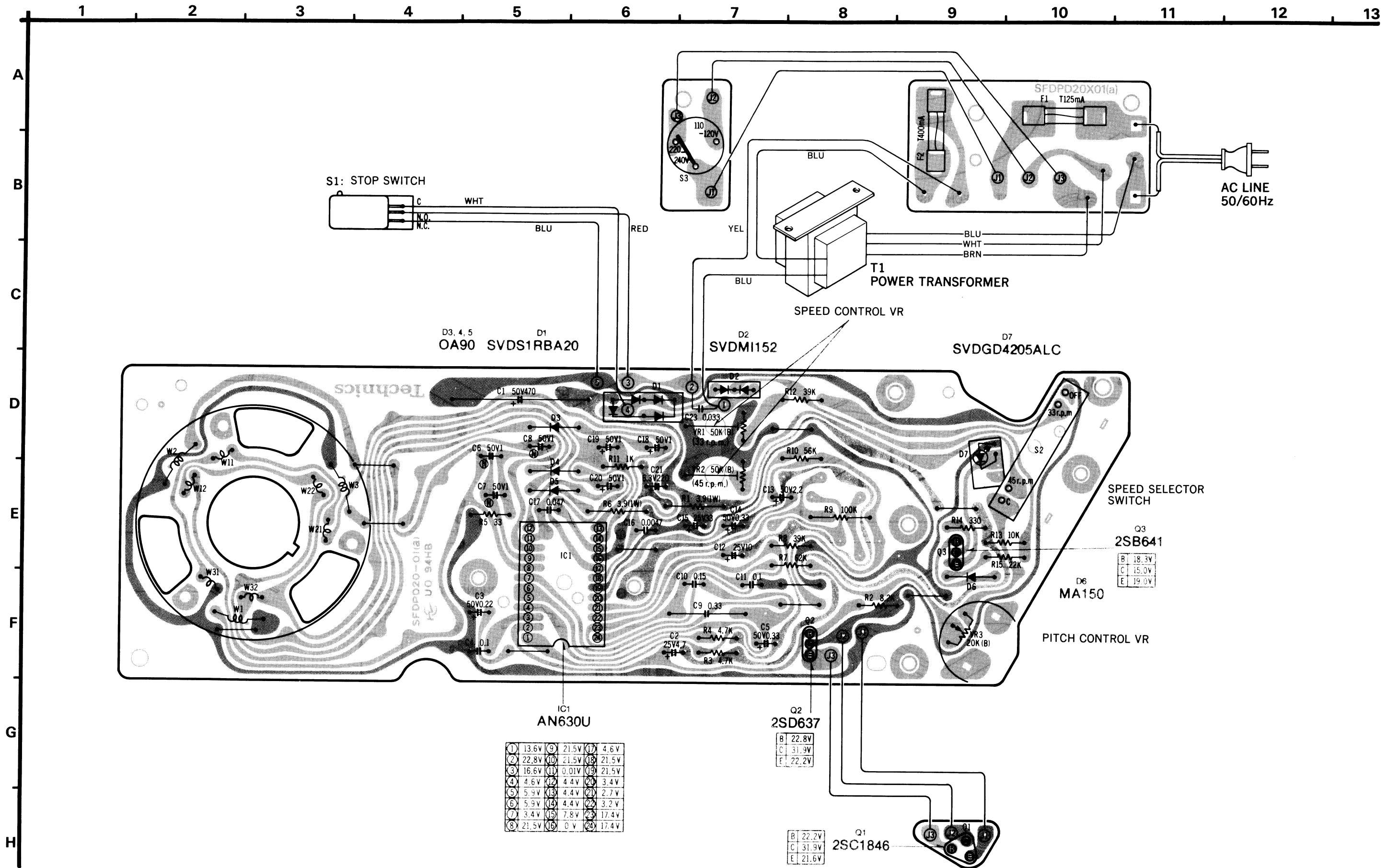

EXPLODED VIEWS

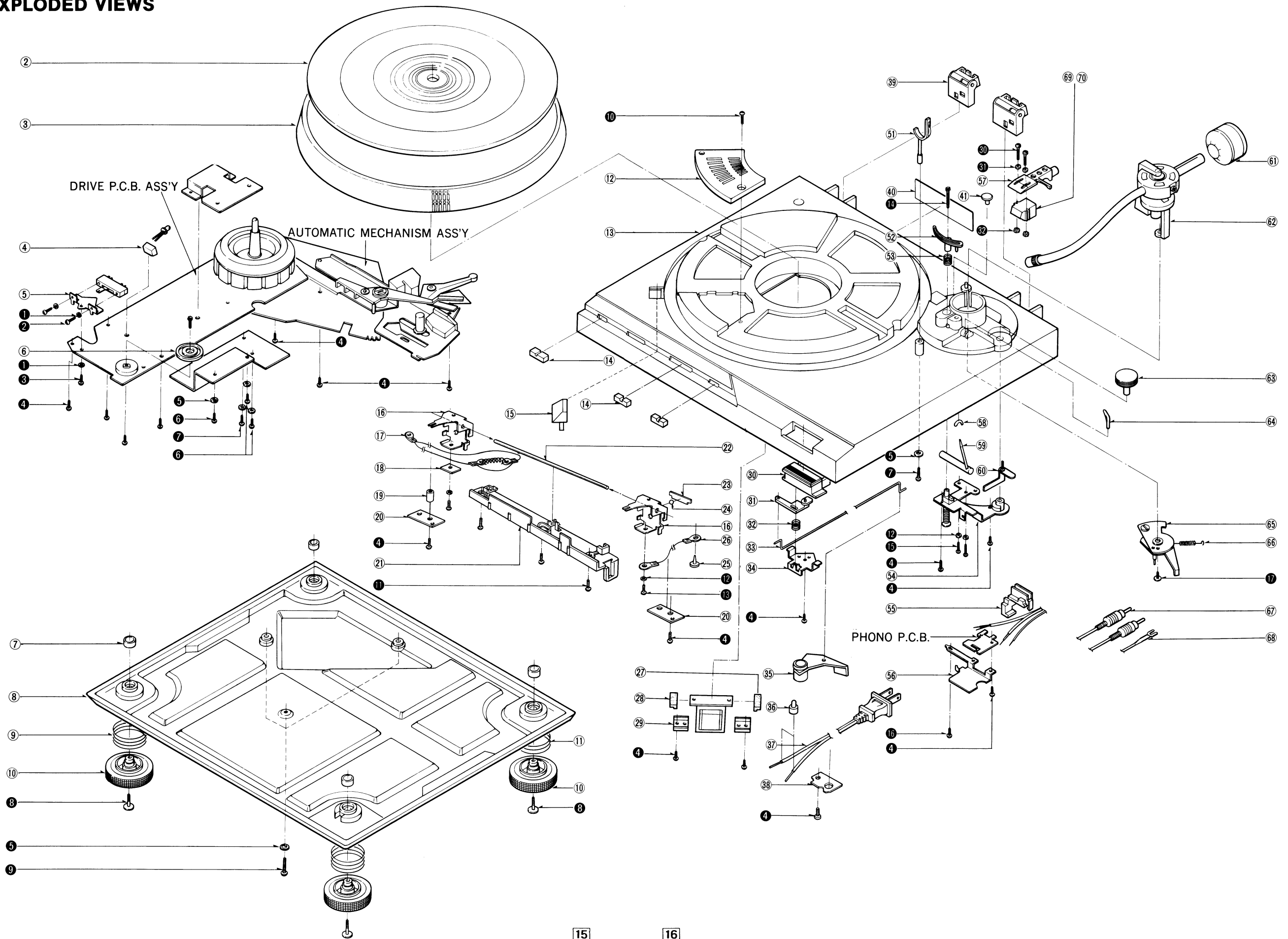

# ■ EXPLODED VIEWS

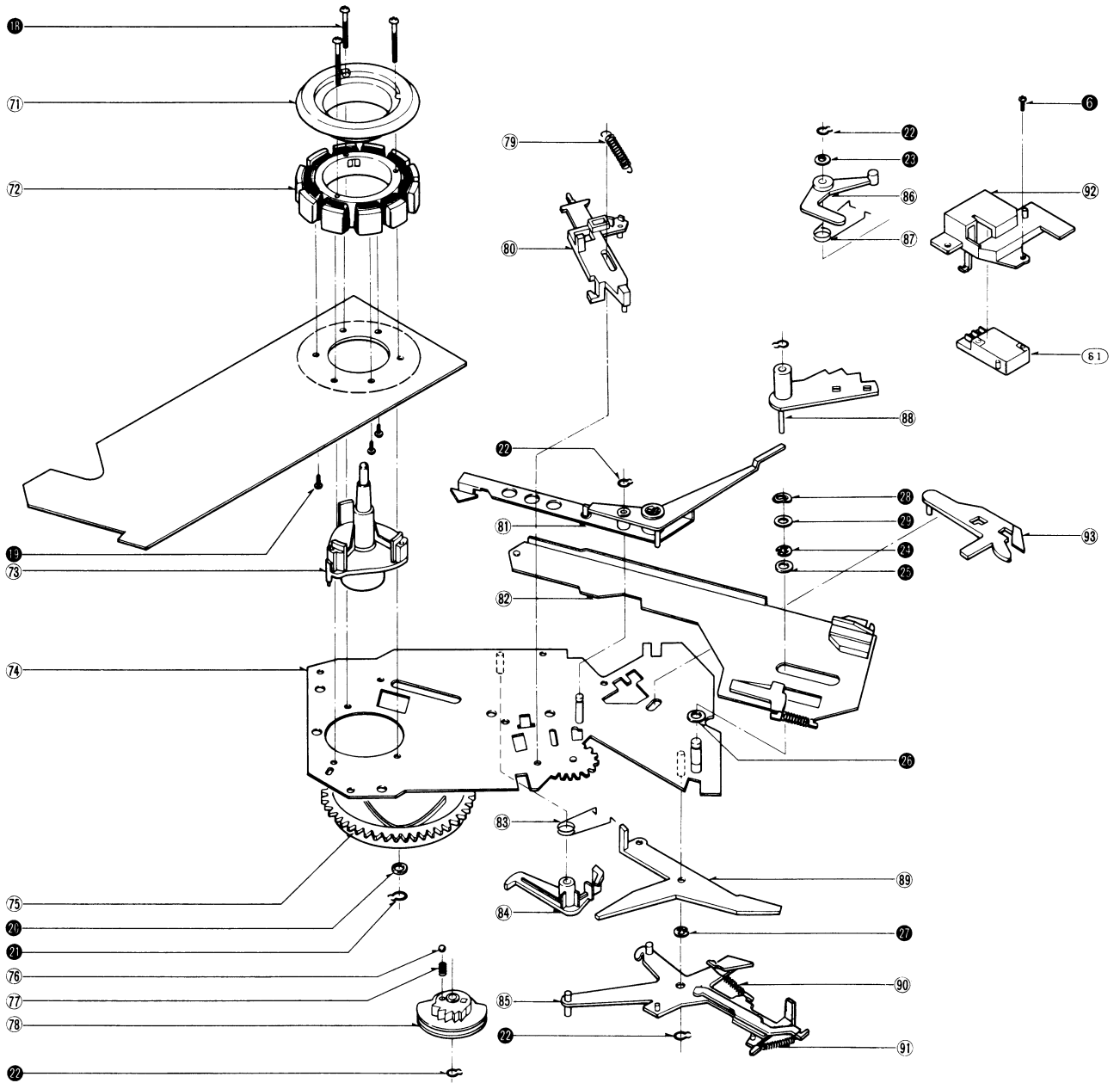

**81 ■ PARTS ARRANGEMENT DIAGRAM**

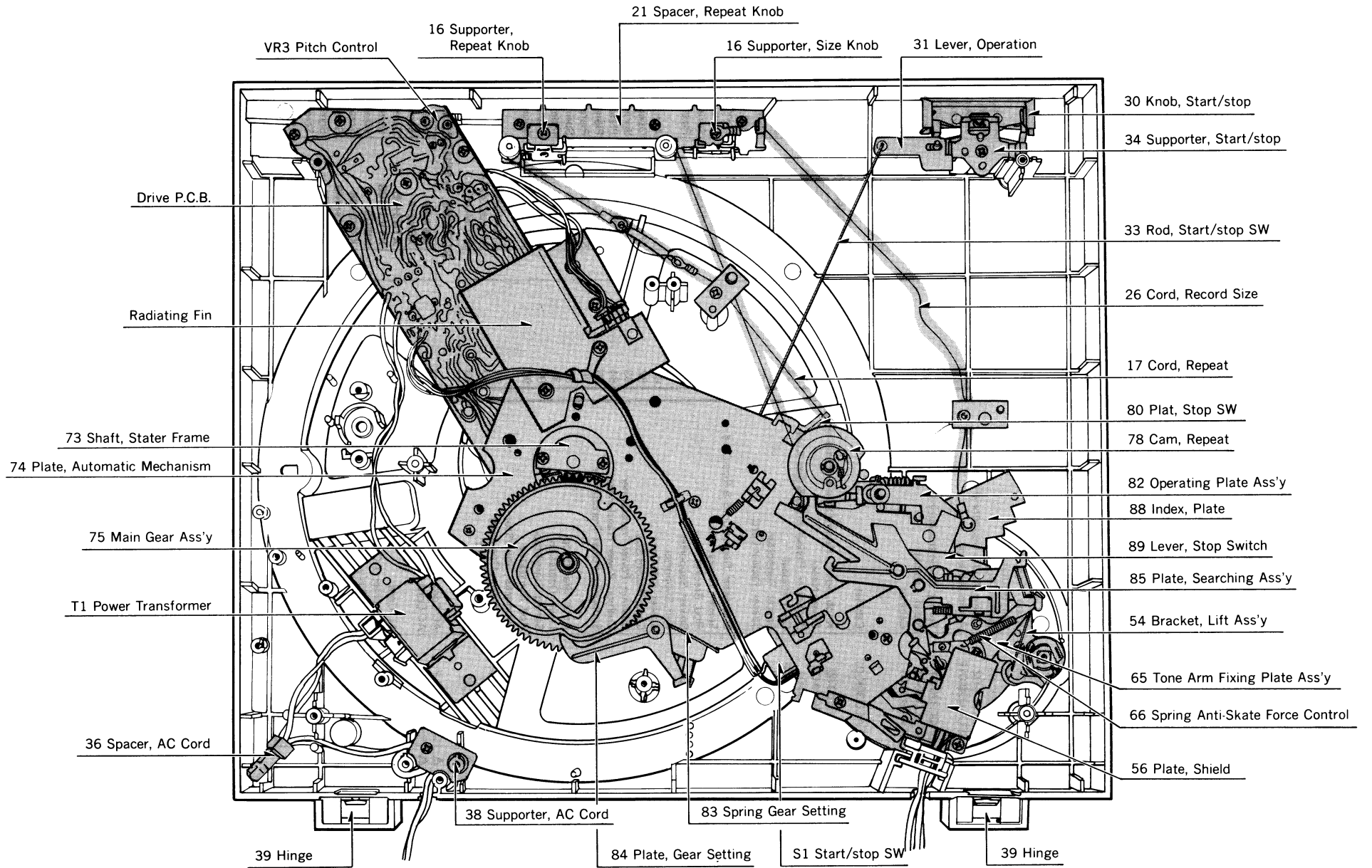

**REPLACEMENT PARTS LIST**



- Notes: 1. Part numbers are indicated on most mechanical parts.  
Please use this part number for parts orders.
2. **△** indicates that only parts specified by the manufacturer be used for safety.
3. SL-D3 (XA) → [XA], SL-D3 (XAL) → [XAL], SL-D3 (XGE) → [XGE],  
SL-D3 (E) → [E], SL-D3 (XG) → [XG], SL-D3 (XGF) → [XGF], SL-D3 (XGB) → [XGB]  
SL-D3K (XAL) → [KXAL], SL-D3K (E) → [KE], SL-D3K (XG) → [KXG]

Ref. No.	Part No.	Part Name & Description	Ref. No.	Part No.	Part Name & Description
<b>CABINET and CHASSIS PARTS</b>					
1	SFADD20-01E	Dust Cover	60	SFXJQ20-03E	Plate, Anti-skate Force Control
2	SFTG320-01	Turntable Mat	61	SFPWG31101K	Balance Weight
3	SFTED20-01A	Turntable	62 [XA, XAL, XGE, E, XG, XGF, XGB]	SFPAM31101K	Tone Arm
4	SFUMD20-02	Spacer, LED	62 [KXAL, KE, KXG]	SFPAM31102K	Tone Arm
5	SFUPD20-04	Plat, Speed Select Switch	63	SFPJK13101	Knob, Anti-skate Force Control
6	SFKTD20-03	Knob, Pitch Control	64	SFPAB13202	Knob, Cueing Lever
7	SFXWD20-01	Cap, Bottom Board	65	SFUPQ20-03A	Tone Arm Fixing Plate Ass'y
8	SFAUQ20-01	Bottom Board	66	SFPP00101	Spring, Anti-skate Force Control
9	SFQC200-02	Spring, Audio Insulator (Front)	67	SFDH212-01	Phono Cord
10	SFGAQ20-01E	Audio Insulator	68	SFKU212-01E	Ground Wire
11	SFQC320-01	Spring, Audio Insulator (Rear)	69	EPC270CK2K-X	Cartridge
12	SFKCD20-01	Panel, Cabinet	70	EPS270ED	Stylus
13 [XA, XAL, XGE, E, XG, XGF, XGB]	SFACD30-01	Cabinet	<b>AUTOMATIC MECHANISM ASS'Y</b>		
13 [KXAL, KE, KXG]	SFACD30K-01	Cabinet	71	SFMGQ20-01	Cover, Stater Frame Ass'y
14	SFKTD20-02	Knob, Speed, Record Size & Memo-repeat	72	SFMG170-01A	Stater Frame
15	SFUMQ20-05	Cover, Neon	73	SFMZQ20-01A	Shaft, Stater Frame Ass'y
16	SFUPD30-01	Supporter, Repeat Knob & Size Knob	74	SFUKD30-11E	Plate, Automatic Mechanism
17	SFUZD30-02E	Cord, Repeat	75	SFUG190-22E	Main Gear Ass'y
18	SFUPD30-02	Spacer, Supporter	76	SFYB-5-32	Ball, Repeat Cam
19	SFXOD30-01	Spacer, Repeat Cord	77	SFQAQ30-01	Spring, Repeat Cam
20	SFUPD30-03	Supporter, Repeat Cord & Size Cord	78	SFUMQ30-13	Cam, Repeat
21	SFUMD30-01E	Spacer, Repeat Knob	79	SFQHD30-01	Spring, Stop SW Plate
22	SFXJD30-01	Rod, Bracket	80	SFUMQ30-14E	Plate, Stop SW
23	SFQPD30-01	Spacer, Supporter	81	SFUCQ20-11E	Actuating Plate Ass'y
24	SFYB-5-32	Ball, Supporter	82	SFUBQ30-11A	Operating Plate Ass'y
25	SFUZQ30-04	Spacer, Size Cord	83	SFQS222-11	Spring, Gear Setting
26	SFUZD30-01E	Cord, Record Size	84	SFUM222-11	Plate, Gear Setting
27	SFGCD20X02	Cushion, Power Transformer	85	SFUMQ30-11E	Plate, Searching Ass'y
28	SFGCD20X01	Cushion, Power Transformer	86	SFUMQ20-19	Plate, Brake
29	SFUPD20-02	Supporter, Power Transformer	87	SFQSQ20-13	Spring, Brake Plate
30	SFKTD20-01	Knob, Start/Stop	88	SFUMQ30-12	Index, Plate
31	SFUMD20-01	Lever, Operation	89	SFUMQ20-17	Lever, Stop Switch
32	SFQAD20-01	Spring, Start/Stop	90	SFQHQ30-14	Spring, Searching Plate
33	SFUZD30-01	Rod, Start/Stop	91	SFQHQ30-13	Spring, Searching Plate
34	SFUPD20-03	Supporter, Start/Stop	92	SFUMQ30-18	Cover, Stop Switch
35	SFUMD30-02	Supporter, Operating	93	SFUMQ20-16	Supporter, Stop Switch
36	SJE41	Spacer, AC Cord	<b>SCREWS, WASHERS and CIRCLIPS</b>		
37 [XA, XG, KXG, XGF, XGB]	△ RJA23ZC-K	AC Cord	①	XWA2B	Washer
37 [XAL, KXAL]	△ QFC1208M-P	AC Cord	②	XSN2+4	Screw
37 [XGE] only	△ RJA45ZC-K	AC Cord	③	XTN3+6B	Screw
38	△ RJA23C-K	AC Cord	④	XTV3+10B	Screw
39	SFUP202-03	Supporter, AC Cord	⑤	XWG3	Washer
40 [XA, XG, XGF, XGB]	SFAT301-01A	Hinge Ass'y	⑥	XTV3+8B	Screw
40 [XAL, KXAL, XGE]	SFNN30X01	Name Plate	⑦	XTV3+14B	Screw
40 [E, KE]	SFNN30G01	Name Plate	⑧	SFXGD20-01	Screw
40 [KXG] only	SFNN30S01	Name Plate	⑨	XTV3+20B	Screw
41 [XA, XAL, XGE, E, XG, XGF, XGB]	SFNN30K03	Name Plate	⑩	XTV3+10BFZ	Screw
41 [KXAL, KE, KXG]	SFGK170-01	Cap, Rubber	⑪	XTV3+14BFN	Screw
	SFGK171F01	Cap, Rubber	⑫	XWA3B	Washer
			⑬	XSN3+8S	Screw
			⑭	SFXG829-1	Screw
			⑮	XSN3+12S	Screw
			⑯	XTN3+8B	Screw
			⑰	SFPEV13204	Screw
			⑱	SFXGQ20-02	Screw
			⑳	XTN26+6B	Screw
			㉑	SFXW890B01	Washer
			㉒	XUB6FT	Circlip
			㉓	XUB4FT	Circlip
			㉔	XWA4A10BW	Washer
			㉕	XUC5FT	Circlip
			㉖	SFXW623-2	Washer
			㉗	SFXW130-13	Washer
			㉘	XUC3FT	Circlip
<b>AXIS and ARM BASE</b>					
51	SFKU212-01E	Arm Rest			
52	SFPRT13004K	Lift Ass'y			
53	SFQA829-03	Spring, Lift Ass'y			
54	SFUPD20-01A	Bracket, Lift Ass'y			
55	SFUM212-08	Clamper, Cord			
56	SFUP683R04	Plate, Shield			
57	SFPCC31001K	Headshell			
58	SFGZD20-02	Supporter, Cueing			
59	SFPJL00101K	Lever, Cueing			



**REPLACEMENT PARTS LIST**

- Notes:** 1. Part numbers are indicated on most mechanical parts.  
Please use this part number for parts orders.  
2.  $\Delta$  indicates that only parts specified by the manufacture be used safety.  
3. SL-D3 (XA)  $\rightarrow$  [XA], SL-D3 (XAL)  $\rightarrow$  [XAL], SL-D3 (XGE)  $\rightarrow$  [XGE],  
SL-D3 (E)  $\rightarrow$  [E], SL-D3 (XG)  $\rightarrow$  [XG], SL-D3 (XGF)  $\rightarrow$  [XGF], SL-D3 (XGB)  $\rightarrow$  [XGB]  
SL-D3K (XAL)  $\rightarrow$  [KXAL], SL-D3K (E)  $\rightarrow$  [KE], SL-D3K (XG)  $\rightarrow$  [KXG]

Ref. No.	Part No.	Part Name & Description
	SFPEW13005	Washer
	SFXW230-11	Washer
	SFPEV9801	Screw
	SFPEV9801	Screw
	SFPEN3302	Nut
	SFPEW9601	Washer
<b>ACCESSORIES</b>		
A1 [XA, XAL, KXAL, XG, KXG, XGF, XGB]	SFNUD30X01	Instruction Book
A1 [XGE] only	SFNUD30G01	Instruction Book
A1 [E, KE]	SFNUD30S01	Instruction Book
A2	SFWE212-01	Adaptor, 45 r.p.m.
A3	SFYF05A06	Polyethylene Bag
A4	SFPZB3501	Shell Weight

Ref. No.	Part No.	Part Name & Description
<b>PACKING PARTS</b>		
P1 [XA, XAL, XGE, E, XG, XGB]	SFHDP30M01	Carton
P1 [KXAL, KE, KXG]	SFHDP30K01	Carton
P1 [XGF] only	SFHDP30C01	Carton
P2	SFHHD20-01	Pad, Front
P3	SFHHD20-02	Pad, Rear
P4	SFHD230-01	Pad, Top
P5	SFHDD20-02	Pad, Turntable
P6	SFYH60X60	Polyethylene Cover, Player Unit
P7	SFYH60X60	Polyethylene Cover, Dust Cover
P8	SFYH40X45	Polyethylene Cover, Turntable

Ref. No.	Part No.	Part Name & Description
<b>INTEGRATED CIRCUIT</b>		
IC1	AN630U	Integrated Circuit
<b>TRANSISTORS</b>		
Q1	2SC1846-R	Transistor
Q2	2SD637	Transistor
Q3	2SB641	Transistor
<b>DIODES</b>		
D1	$\Delta$ SVDSIRBA40	Rectifier
D2	$\Delta$ SVDMI152	Rectifier
D3, 4, 5	20A90	Diode
D6	MA161	Diode
D7, 9	SVDGD4205ALC	Light Emitting Diode
<b>TRANSFORMER</b>		
T1	$\Delta$ SLT5352B	Power Transformer
<b>FUSE</b>		
F1	$\Delta$ XBA2C012TRO	125mA, Fuse
F2	$\Delta$ XBA2C04TRO	400mA, Fuse
<b>SWITCHES</b>		
S1	$\Delta$ SFDSA74403	Switch, Power
S2	$\Delta$ EVAH27SBAAAY	Switch, Speed Selector
S3	$\Delta$ SFDSHXW13312	Switch, Power Selector
<b>VARIABLE RESISTORS</b>		
VR1, 2	EVLS6AA00B54	50k $\Omega$ (B), Speed Control (33 r.p.m. & 45 r.p.m.)
VR3	EVJ61AT12B24	20k $\Omega$ (B), Pitch Control

Ref. No.	Part No.	Part Name & Description
<b>RESISTORS</b>		
R1	ERX1ANJ3R9	Metallic, 3.9 $\Omega$ , 1W, $\pm$ 5%
R2	ERD25FJ822	Carbon, 8.2k $\Omega$ , 1/4W, $\pm$ 5%
R3, 4	ERD25FJ472	Carbon, 4.7k $\Omega$ , 1/4W, $\pm$ 5%
R5	ERD25FJ330	Carbon, 33 $\Omega$ , 1/4W, $\pm$ 5%
R6	ERX1ANJ3R9	Metallic, 3.9k $\Omega$ , 1W, $\pm$ 5%
R7	ERO25CKF6202	Metal Film, 62k $\Omega$ , 1/4W, $\pm$ 1%
R8	ERD25TJ393	Carbon, 39k $\Omega$ , 1/4W, $\pm$ 5%
R9	ERD25TJ104	Carbon, 100k $\Omega$ , 1/4W, $\pm$ 5%
R10	ERD25TJ563	Carbon, 56k $\Omega$ , 1/4W, $\pm$ 5%
R11	ERD25FJ102	Carbon, 1k $\Omega$ , 1/4W, $\pm$ 5%
R12	ERO25CKF3902	Metal Film, 39k $\Omega$ , 1/4W, $\pm$ 2%
R13	ERD25FJ103	Carbon, 10k $\Omega$ , 1/4W, $\pm$ 5%
R14	ERD25FJ331	Carbon, 330 $\Omega$ , 1/4W, $\pm$ 5%
R15	ERD25TJ223	Carbon, 22k $\Omega$ , 1/4W, $\pm$ 5%
<b>CAPACITORS</b>		
C1	ECEB1HS471	Electrolytic, 470 $\mu$ F, 50V
C2	ECEA25Z4R7	Electrolytic, 4.7 $\mu$ F, 25V
C3	ECEA50ZR22	Electrolytic, 0.22 $\mu$ F, 50V
C4	ECQM1H104KS	Polyester, 0.1 $\mu$ F, 50V, $\pm$ 10%
C5	ECEA50ZR33	Electrolytic, 0.33 $\mu$ F, 50V
C6, 7	ECEA50N1	Non-polar Electrolytic, 1 $\mu$ F, 50V
C8	ECEA50N1	Non-polar Electrolytic, 1 $\mu$ F, 50V
C9	ECQF2334KZ	Polypropylene, 0.33 $\mu$ F, 200V, $\pm$ 10%
C10	ECQM1H154KZ	Polyester, 0.15 $\mu$ F, 50V, $\pm$ 10%
C11	ECQM1H104KS	Polyester, 0.1 $\mu$ F, 50V, $\pm$ 10%
C12	ECEA25M10R	Electrolytic, 10 $\mu$ F, 25V
C13	ECEA50M2R2R	Electrolytic, 2.2 $\mu$ F, 50V
C14	ECEA50MR33R	Electrolytic, 0.33 $\mu$ F, 50V
C15	ECEA1VS330	Electrolytic, 33 $\mu$ F, 25V
C16	ECQM1H472KZ	Polyester, 0.0047 $\mu$ F, 50V, $\pm$ 10%
C17	ECQM1H473KZ	Polyester, 0.0047 $\mu$ F, 50V, $\pm$ 10%
C18, 19	ECEA50Z1	Electrolytic, 1 $\mu$ F, 50V
C20	ECEA50Z1	Electrolytic, 1 $\mu$ F, 50V
C21	ECEA1AS221	Electrolytic, 220 $\mu$ F, 10V
C23	ECQM1H333KZ	Polyester, 0.0033 $\mu$ F, 50V, $\pm$ 10%

# Service Manual

Turntable System

## SL-D3

(XFE), (ES)

SL-D3

- \* The model SL-D3 (XFE) is available in East PX only.
- \* The model SL-D3 (ES) is available in European Military only.

For additional information, please refer to the service manual for Model No. SL-D3/K (ORDER NO. SD7906-1581)

- Notes:**
- \* This service manual includes only the changes of the **SL-D3/K** service manual (ORDER NO. SD7906-1581)
  - \* When servicing models **SL-D3 (XFE, ES)** this service manual and **SL-D3/K (ORDER NO. SD7906-1581)** service manual should be used together.

## MODIFICATIONS-1

### ■ SPECIFICATIONS (Page 1)

#### Cartridge section

**Model No.** EPC-270C  
**Type:** Moving magnet  
**Frequency response:** 20 Hz to 25 kHz  
 20 Hz to 15 kHz  $\pm 2$  dB  
**Output voltage:** 3.2 mV at 1 kHz  
 5 cm/s. zero to peak lateral velocity  
**Output voltage:** [9 mV at 1 kHz 10 cm/s. zero to peak 45° velocity (DIN 45 500)]  
**Channel separation:** 25 dB at 1 kHz  
**Channel balance:** Within 2 dB at 1 kHz  
**Compliance (dynamic):**  $10 \times 10^{-6}$  cm/dyne at 100 Hz  
**Stylus pressure:**  $1.75 \pm 0.25$  g ( $17.5 \pm 2.5$  mN)  
**Load impedance:** 47 k $\Omega$  to 100 k $\Omega$   
**Weight:** 6.0 g (cartridge only)  
**Replacement stylus:** EPS-270SD



#### Cartridge section

**Type:** Moving magnetic stereo cartridge  
**Frequency response:** 20 Hz to 25 kHz  
**Output voltage:** 2.5 mV 1 kHz, 5 cm/s.  
 zero to peak lateral velocity  
 (7 mV 1 kHz, 10 cm/s.  
 zero to peak 45° velocity)  
**Channel separation:** 22 dB at 1 kHz  
**Channel balance:** Within 2 dB at 1 kHz  
**Load impedance:** 47 k $\Omega$  to 100 k $\Omega$   
**Stylus pressure:**  $1.75 \pm 0.25$  g  
**Replacement stylus:** EPS-74STSD (ATN71)

# Technics

Panasonic Tokyo

Matsushita Electric Industrial Co., Ltd.  
 17-15, 6-chome, Shinbashi, Minato-ku, Tokyo 105 Japan

Matsushita Electric Trading Co., Ltd.  
 P.O. Box 288, Central Osaka Japan

# MODIFICATIONS-2

## ■ REPLACEMENT PARTS LIST (Page 19, 20)

Ref. No.	Change of Part No.		Part Name & Description
	SD7906-1581	SL-D3 (XFE, ES)	
<b>POWER TRANSFORMER</b>			
T1	SLTF5352B	SLTF5352A	Power Transformer
<b>CABINET and CHASSIS PARTS</b>			
13	SFACD30-01 SFACD30K01	SFACD30-01	Cabinet
36	SJE41	Deletion	-----
37	RJA23ZC QFC1208M RJA45ZC	SJA89	AC Cord
40	SFNND30X01 SFNND30G01 SNFFD30S01 SFNND30K03	SFNND30E01	Name Plate
41	SFGK170-01 SFGK171F01	SFGK171-01	Cap, Rubber
<b>STONE ARM and ARM BASE</b>			
62	SFPAM31101K SFPAM31102K	SFPAM31101K	Tone Arm
69	EPC270CK	EPC74SMAD	Cartridge
70	EPS270ED	EPS74STSD	Stylus
<b>SCREWS, WASHERS and CIRCLIPS</b>			
⑩	SFPEV9801	SFPEV7803	Screw
<b>ACCESSORIES</b>			
A1	SFNUD30X01 SFNUD30G01 SFNUD30S01	SFNUD30P01	Instruction Book
A5	Addition	QJP0603S	Adaptor, Gimens
<b>PACKING PARTS</b>			
P1	SFHPD30M01 SFHPD30K01 SFHPD30C01	SFHPD30M01	Carton