

Service  
Service  
Service



45 281 A11

# Service Manual

COMPACT  
disc  
DIGITAL AUDIO

## CONTENTS

Connections and controls	2
Specification	2
Service program	3-4
Dismantling of the set	5-6
Exploded view (tray)	7
Mechanical partslist (tray)	7
Circuit diagram <b>CD-PART</b>	8-10
Alignment instructions	11
Printed circuit board (componentside)	11-12
Circuit diagram <b>CONTROL-PART</b>	13-14
Wiring diagram (copperside)	15-16
Mechanical partslist (set)	17
Exploded view (set)	17-18
Electrical partslist	19

### (S) Varning!

Osynlig laserstrålning när denna del är öppnad och spärren är urkopplad. Betrakta ej strålen.

### (DK) Advarsel!

Usynlig laserstrålning ved åbning når sikkerhedsafbrydere er ude af funktion. Undgå udsættelse for stråling.

### (SF) Varoitus!

Laitte sisältää laserdiodin, joka lähettää näkymätöntä silmille vaarallista lasersäteilyä.

**CLASS 1  
LASER PRODUCT**

3122 110 03420

## GB Service Testprogramme

To get into service mode hold the keys "SELECT+" and "SELECT-" depressed during switching power on.(µP reset)

The programme goes back to Service pos."1" by pressing "STOP" in any Service position.

Pressing "SELECT-" the tray moves outside. Pressing "SELECT+" the tray moves inside.

### Service pos. "1"

Test of radial servo

The arm is moved towards inner position and on the display the vertical segments are activated (see fig.1). Pressing the key "PREV" the arm is moved outside and on the display the horizontal segments are activated (see fig.2).

### Service pos. "2"

Test of focus servo and disc motor.

The service pos. "2" is activated by pressing "PLAY". The display shows "00 00:00". The laser is switched on and the lens makes an up and down movement according to the applied triangle voltage for focus-search. Pressing "PREV" the turntable motor turns counter clockwise. Pressing "NEXT" the motor turns clockwise. If a disc has been inserted and a focus can be found the display shows "11 11:11".

### Service pos. "3"

The service pos. "3" is activated by pressing "PLAY". The radial control is switched on and if the radial control works correctly, the arm follows the track. The display shows "22 22:22". Pressing "PREV" the arm makes leaps backwards. Pressing "NEXT" the µP reads the subcode. If the subcode reading works, the arm makes leaps forward as long as pressing the "NEXT" key.

To leave the service testprogramme switch off the set.

FIG 1

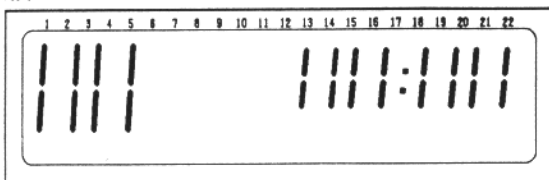

## F Programme de test de service

Pour parvenir en mode de service, maintenez enfoncées les touches "SELECT+" et "SELECT-" tandis que vous mettez l'appareil en circuit (microprocesseur remis à zéro).

Le programme revient en Position de Service "1" si vous appuyez sur "STOP" à partir de n'importe quelle position de service.

Si vous appuyez sur "SELECT-", le plateau se déplace vers l'extérieur. Par pression sur la touche "PRESET+", il se déplace vers l'intérieur.

### Position de Service "1"

Test du servomécanisme radial

Le bras est déplacé vers la position intérieure et des segments verticaux sont activés sur l'afficheur (fig.1). En appuyant sur la touche "PREV" le bras est déplacé vers l'extérieur et des segments horizontaux sont activés sur l'afficheur (fig.2).

### Position de Service "2"

Test du servomécanisme de mise au point et du moteur du plateau

La position de service "2" est activée après pression sur la touche "PLAY". L'afficheur indique "00 00:00". Le laser est mis en circuit et la lentille effectue un mouvement de haut en bas conformément à la tension triangulaire appliquée pour la recherche de mise au point. Si vous appuyez sur "PREV", le moteur du plateau rotatif tourne dans le sens inverse d'horloge. Si vous appuyez sur "NEXT" il tourne dans le sens d'horloge. Si un disque a été introduit et la mise au point trouvée, l'afficheur indiquera "11 11:11".

### Position de Service "3"

La position de service "3" est activée par pression sur la touche "PLAY". La commande radiale est mise en circuit et si elle fonctionne correctement, le bras suit la piste. L'afficheur indique "22 22:22". Si vous appuyez sur "PREV", le bras fait des sauts en arrière. Si vous appuyez sur "NEXT", le microprocesseur lit le sous-code. Si la lecture du sous-code fonctionne bien, le bras fait des sauts en avant tant que vous maintenez enfoncée la touche "NEXT".

Pour quitter le programme de test de service, mettez l'unité hors circuit.

FIG 2

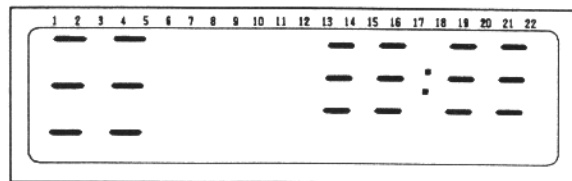

## NL Service

Om in de te schak "SELECT

U kunt herterugkeretoets "ST

Als u "SE Drukt u "

### Service

Controle

De arm b

de vertica

"PREV" in

op het di

figuur 2).

### Service

Controle

U kunt se

drukken.

wordt ing

neergaan

driehoeks

indrukt, d

"NEXT" in

een plaat

focus gev

11:11".

### Service

U kunt se

drukken.

deze goe

display ve

Als u "PR

Als u "NE

toets is in

Om het s

apparaat

## I Pro

Per entra

"SELECT-

accesso (m

Il program

premedo

di servizio

Premendo

l'esterno

sposterà

### Posizione

Test del s

Il braccio

attivati de

"PREV", il

display ve

### Posizione

Test del s

motorino

La posizio

1

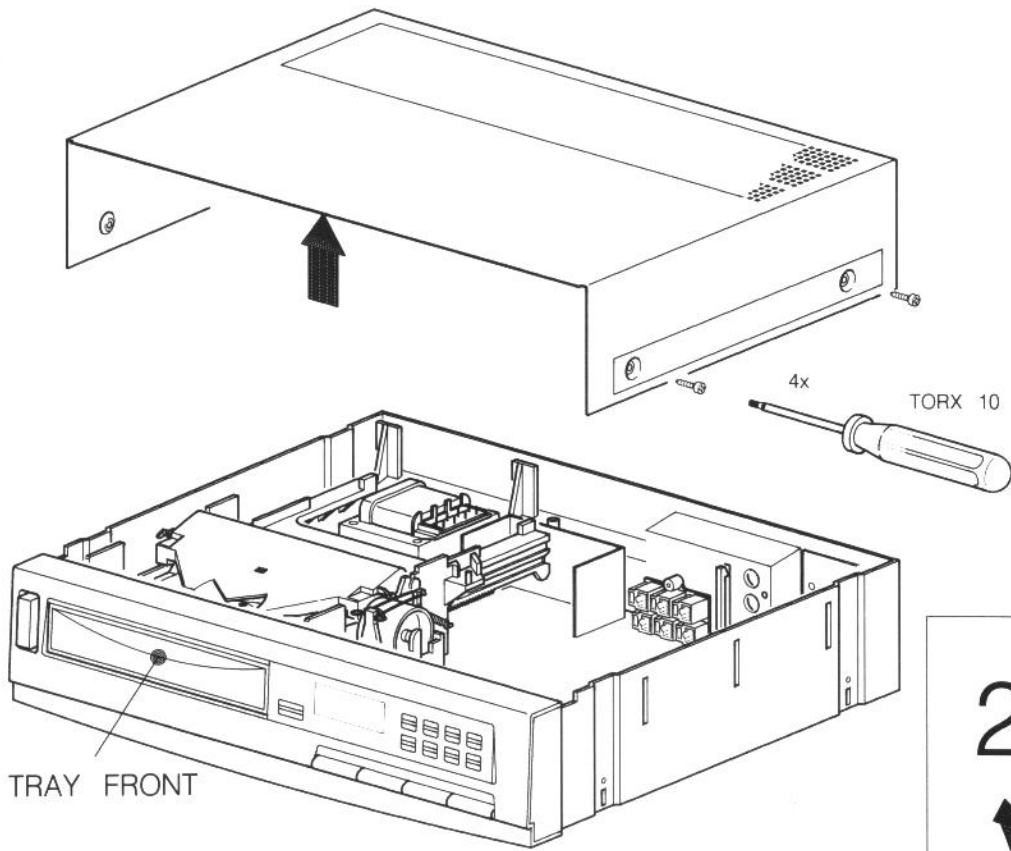

3

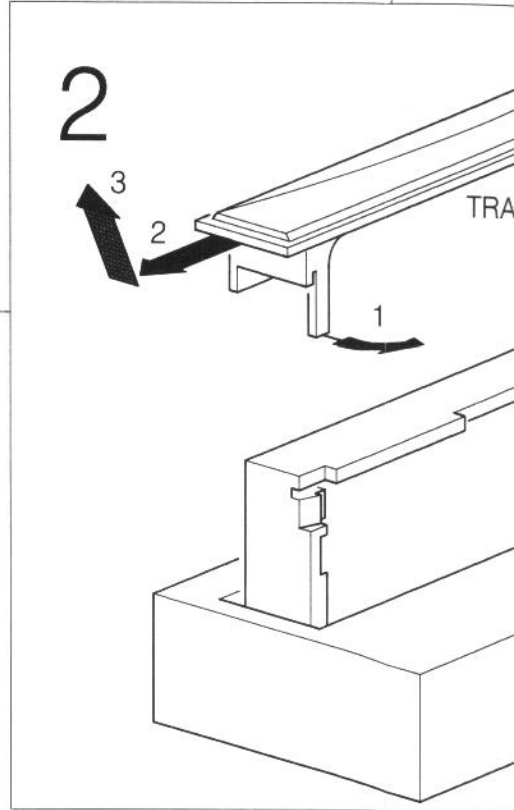

4

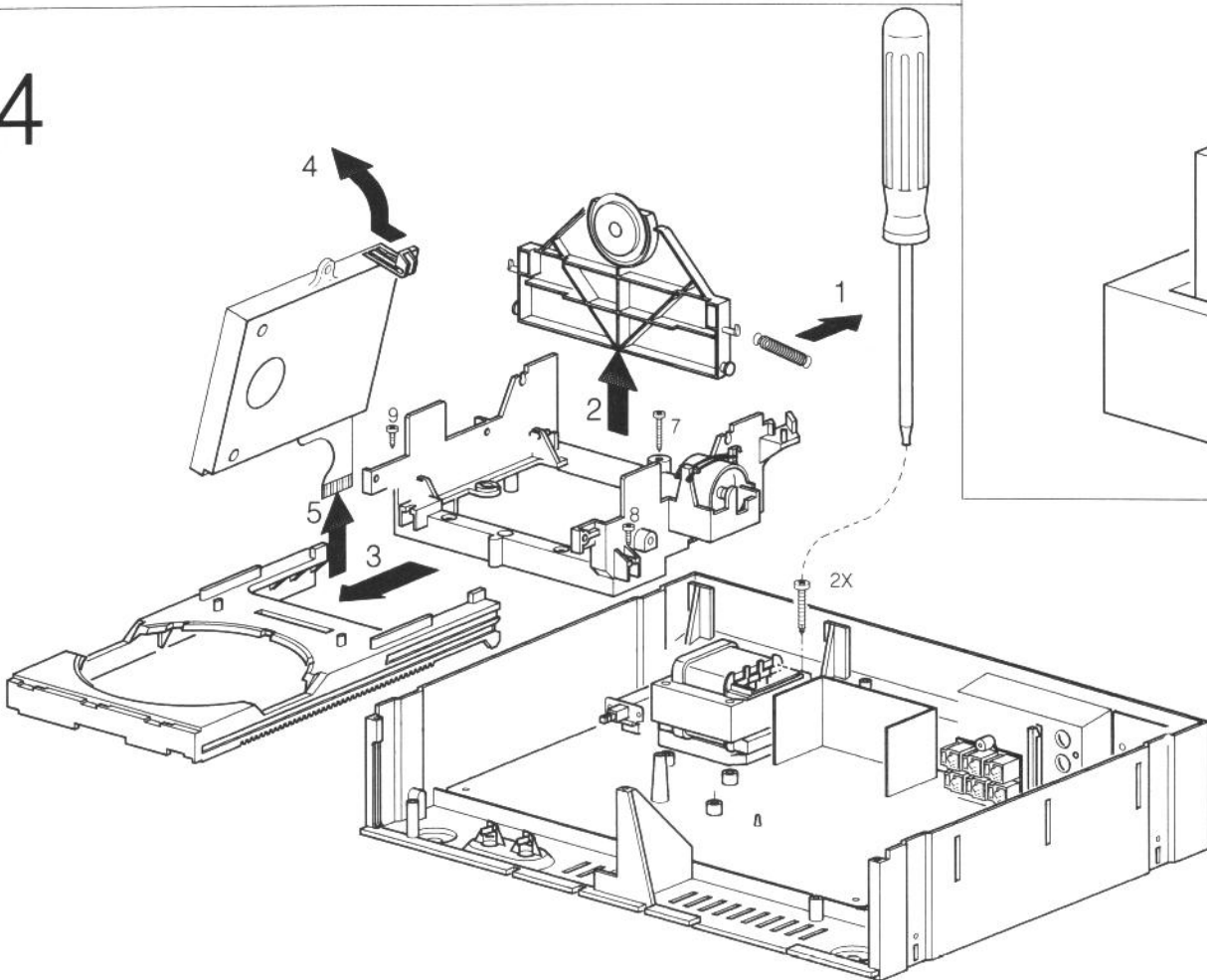

3

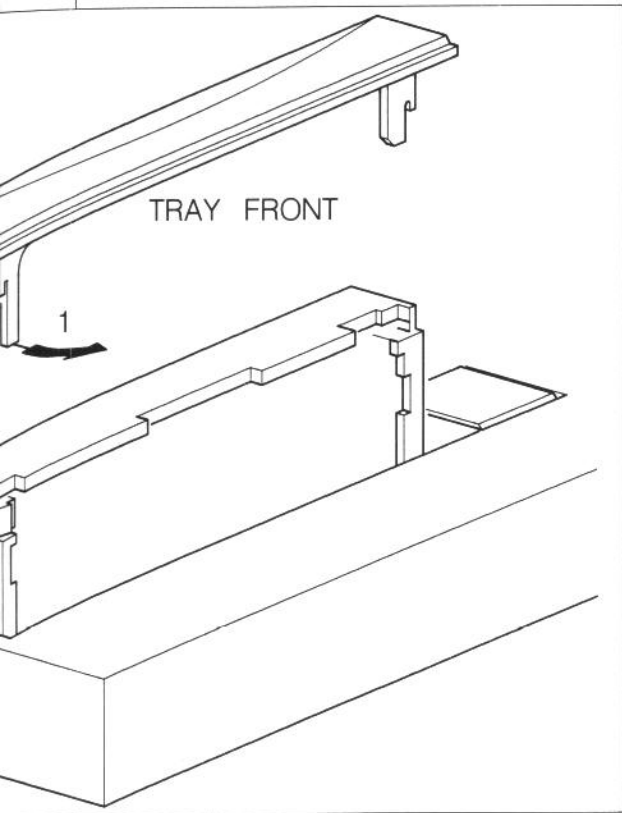
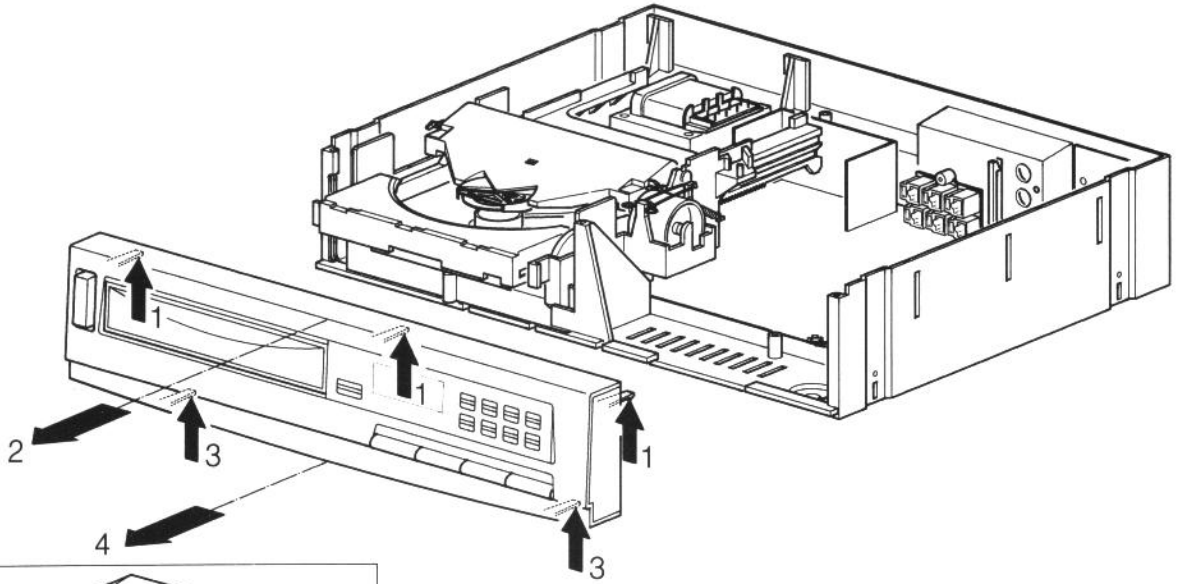

101

102

103

104

5

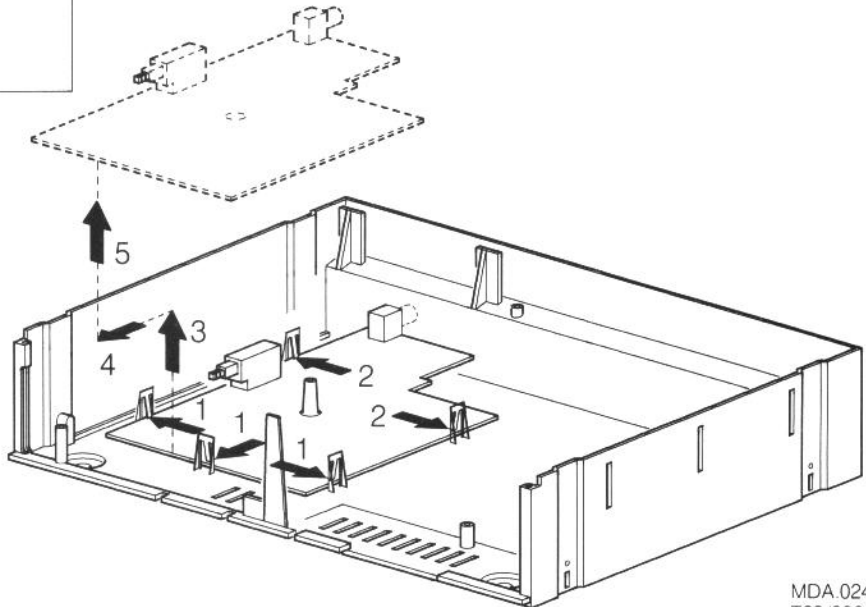

106

107

Loading

101

102

103

104

106

107

108

109

111

112

113

114

116

117

118

LOADING

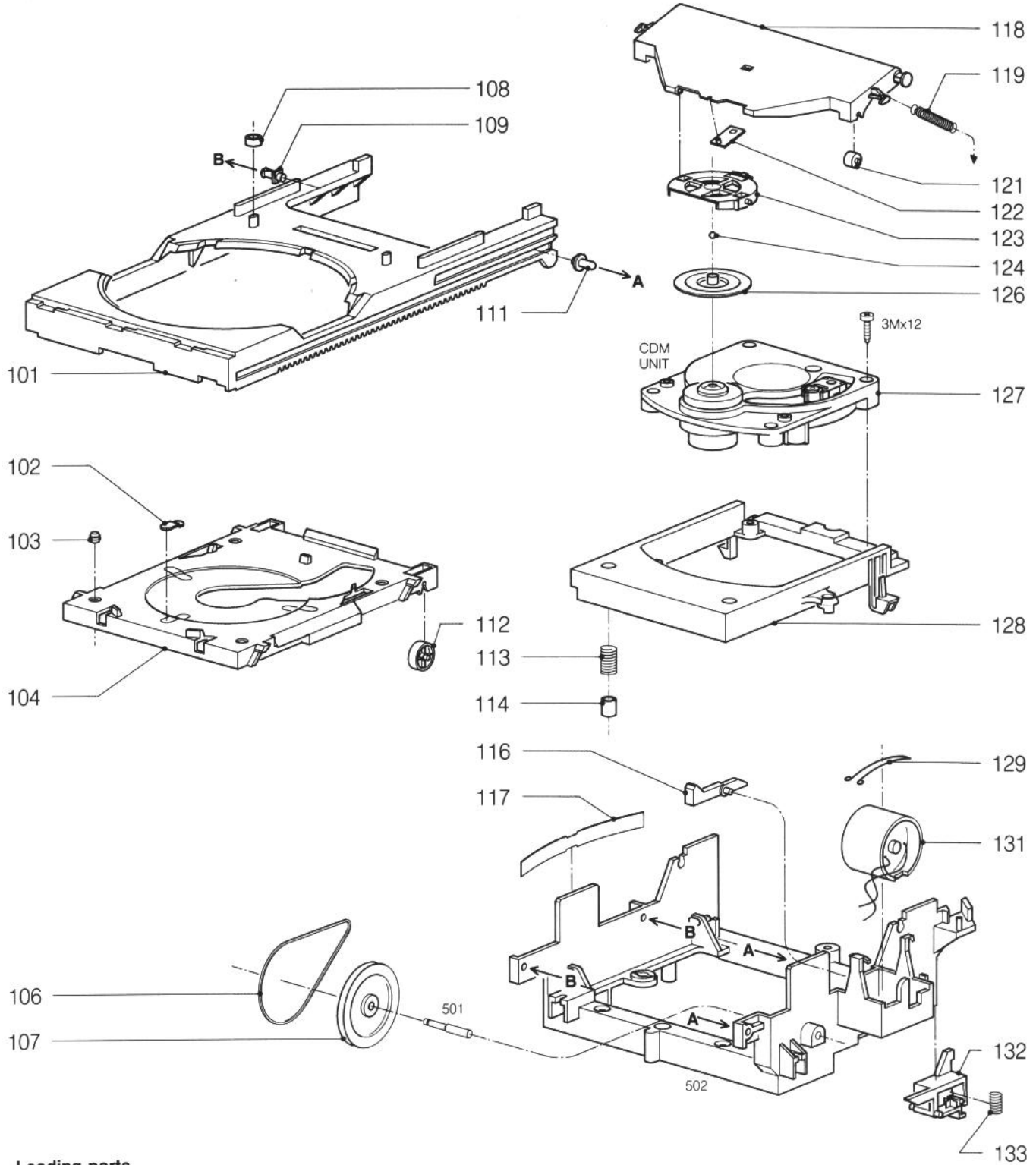

Loading parts

101	4822 444 50626	119	4822 492 32883
102	4822 325 50176	121	4822 528 90639
103	4822 325 50177	122	4822 466 92257
104	4822 466 92251	123	4822 402 61207
106	4822 358 10115	124	4822 520 40177
107	4822 522 32359	126	4822 530 80503
108	4822 532 51756	127	4822 691 30209
109	4822 402 61081	128	4822 402 61196
111	4822 402 61132	129	4822 492 63746
112	4822 528 90638	131	4822 361 21327
113	4822 492 51902	132	4822 402 50281
114	4822 532 61168	133	4822 492 51935
116	4822 402 61107		
117	4822 492 63659		
118	4822 444 60568		

EVA 00594  
907/T19

CD PART

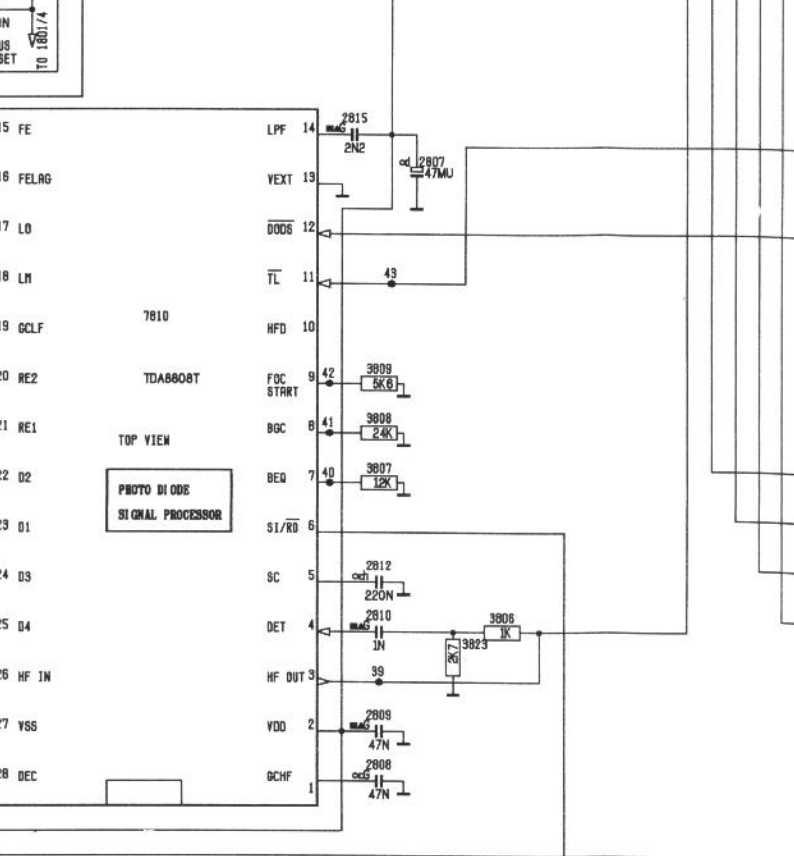
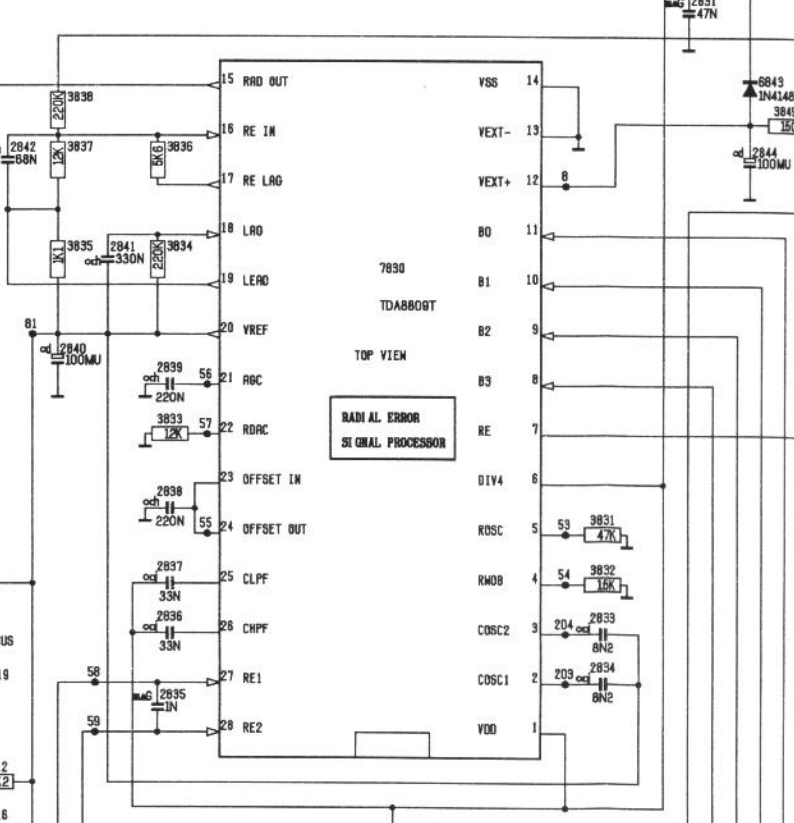
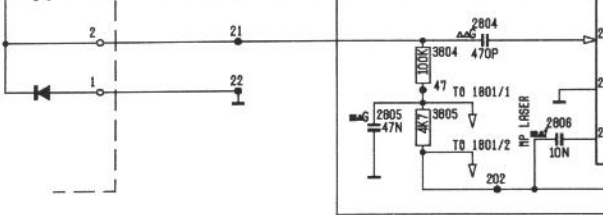
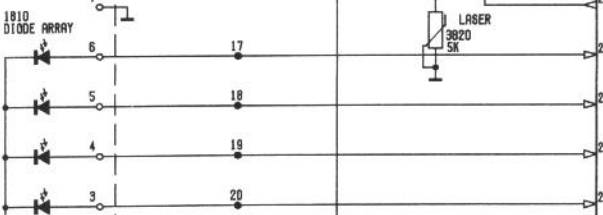
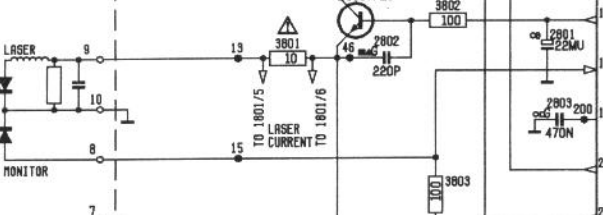
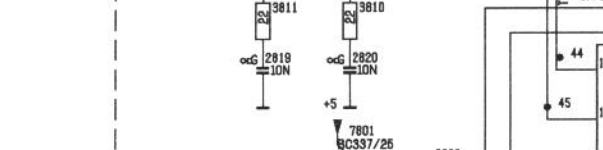
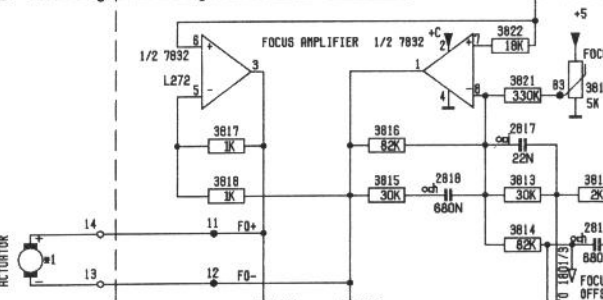
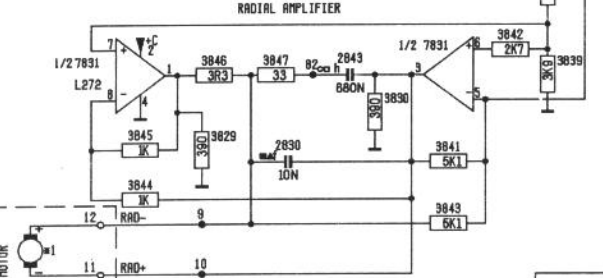
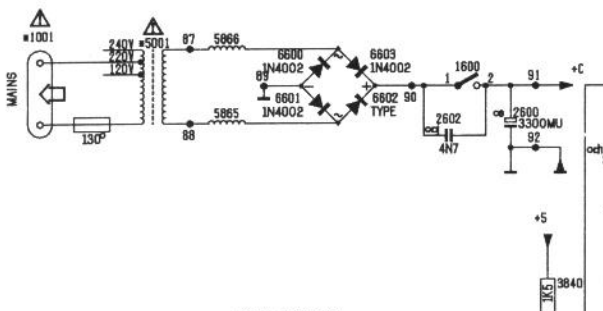

A B C D E F G H I J K L M N O



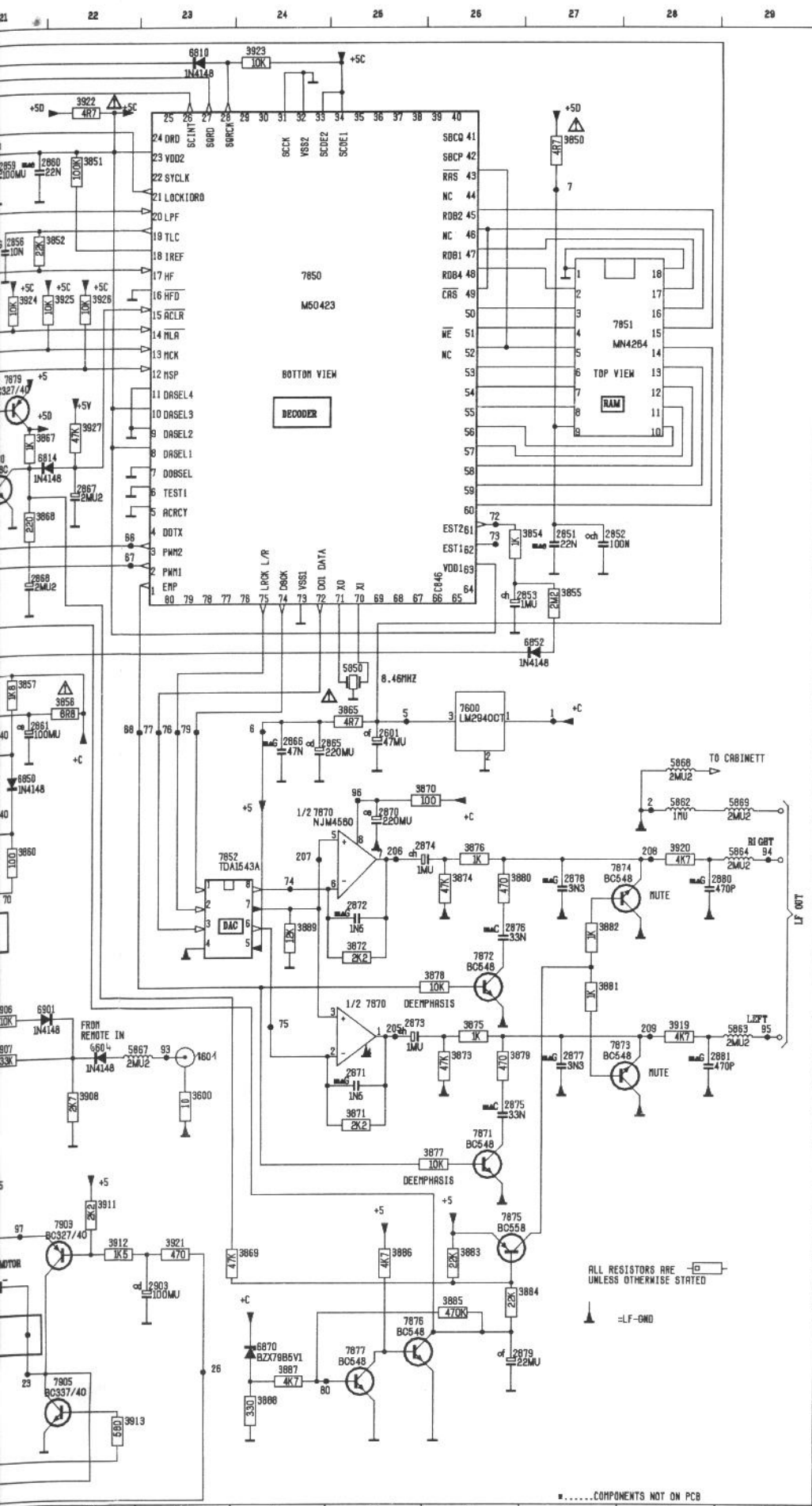

A	#1	F 1	3843	E 4	7856	H21
	#1	J21	3844	E 2	7870	H24
	#1	H 1	3845	E 2	7871	L26
	#1	M21	3846	D 3	7872	J28
	#1001	B 1	3847	D 3	7873	K28
	#5001	B 2	3848	R11	7874	I2E
	1800	B 5	3849	B12	7875	M26
	1801	K22	3850	B27	7876	N25
	1801	D 3	3851	B22	7877	N25
	1810	K 1	3852	C21	7878	E20
	1811	I20	3853	B21	7879	D21
	1812	M21	3854	F26	7880	E21
	1813	J17	3855	F27	7901	K20
	1815	K18	3856	G22	7902	M20
	2600	B 5	3857	G21	7903	M22
	2601	H25	3858	G19	7904	M20
	2602	B 4	3859	I19	7905	M22
	2801	J 5	3860	I21		
	2802	J 4	3863	I18		
	2803	J 5	3864	C20		
	2804	M 5	3865	Q25		
	2805	N 4	3866	E21		
	2806	N 5	3867	E21		
	2807	I 9	3868	E21		
	2808	N 9	3869	M23		
	2809	N 9	3870	H26		
	2810	M 9	3871	L25		
	2812	L 9	3872	J25		
	2815	I 9	3873	K26		
	2816	H 6	3874	I26		
	2817	G 5	3875	K26		
	2818	G 4	3876	I28		
	2819	I 3	3877	L28		
	2820	I 4	3878	J28		
	2830	E 3	3879	K28		
	2831	R11	3880	I28		
	2833	F11	3881	J27		
	2834	G11	3882	J27		
	2835	Q 7	3883	M26		
	2836	F 7	3884	M26		
	2837	F 7	3885	M26		
	2838	E 7	3886	M25		
	2839	D 7	3887	N24		
	2840	D 6	3888	N24		
	2841	C 6	3889	J24		
	2842	B 6	3901	J17		
	2843	D 4	3902	J19		
	2844	B12	3903	J20		
	2845	G17	3904	K20		
	2851	F27	3905	K20		
	2852	F27	3906	J21		
	2853	F28	3907	K21		
	2855	C21	3908	K22		
	2856	C21	3911	L22		
	2857	B20	3912	H22		
	2858	C19	3913	O22		
	2859	B21	3914	O19		
	2860	B21	3915	M20		
	2861	H21	3916	L20		
	2862	C20	3917	I17		
	2865	H24	3919	K28		
	2866	H24	3920	I28		
	2867	E22	3921	M23		
	2868	F21	3922	A22		
	2870	H25	3923	A24		
	2871	K25	3924	C21		
	2872	I25	3925	C21		
	2873	K25	3926	C22		
	2874	I26	3927	E22		
	2875	K26	3928	O25		
	2876	J28	5851	G13		
	2877	K27	5852	J20		
	2878	I27	5853	J21		
	2879	N26	5854	L17		
	2880	I28	5855	L18		
	2881	K28	5856	L18		
	2901	K21	5857	M17		
	2902	K18	5858	M17		
	2903	M23	5859	N17		
	3600	K23	5860	N18		
	3801	J 3	5861	N17		
	3802	J 4	5862	H28		
	3803	K 4	5863	K29		
	3804	H 4	5864	I28		
	3805	N 4	5865	B 3		
	3806	H10	5866	B 3		
	3807	L 9	5867	K23		
	3808	K 8	5868	H28		
	3809	K 9	5869	H28		
	3810	H 4	6600	B 3		
	3811	H 3	6601	B 3		
	3812	G 6	6602	B 4		
	3813	G 5	6603	B 4		
	3814	H 5	6604	K23		
	3815	G 4	6811	C19		
	3816	G 4	6811	E22		
	3817	G 3	6812	D19		
	3818	G 3	6813	O20		
	3819	G 5	6814	A23		
	3820	L 4	6840	I17		
	3821	G 5	6841	J17		
	3822	F 5	6842	M17		
	3823	H 9	6843	B12		
	3824	J17	6850	H21		
	3825	E19	6851	H19		
	3826	E20	6852	O27		
	3827	O20	6870	N24		
	3828	O20	6901	J22		
	3829	E 2	7600	O26		
	3830	E 4	7801	I 4		
	3831	E11	7810	J 7		
	3832	F11	7830	C 9		
	3833	E 7	7831	D 1		
	3834	C 7	7832	F 2		
	3835	C 6	7840	I15		
	3836	B 7	7841	E13		
	3837	B 6	7850	C24		
	3838	B 6	7851	O27		
	3839	D 5	7852	I23		
	3840	D 5	7853	H20		
	3841	E 4	7854	H20		
	3842	D 5	7855	H21		

.....COMPONENTS NOT ON PCB



1700	A 6	1709	F 15	1812	F 7	2804	B 4	2818	H 3	2839	F 2	2854	F 8	2870	C 9	2881	D 11	3802	E 9	3813	D 3	3829	D 2	3840	C 3
1601	B 2	1710	F 15	1813	G 7	2805	B 5	2819	F 2	2840	F 2	2855	D 5	2871	C 9	2901	F 2	3803	E 9	3814	D 3	3830	C 2	3841	C 2
1700	E 11	1711	F 14	1815	H 8	2806	C 5	2820	A 2	2841	D 2	2856	C 5	2872	B 8	2907	F 4	3804	E 9	3815	B 2	3831	E 3	3842	C 3
1701	D 16	1712	F 14	2	E 11	2807	D 5	2830	C 1	2842	D 2	2857	F 5	2873	C 8	2903	C 7	3805	E 5	3816	B 2	3832	E 3	3843	C 2
1702	B 4	1713	F 9	2800	B 8	2808	C 4	2831	F 3	2843	C 1	2858	F 5	2874	C 8	3	F 12	3806	C 5	3817	B 2	3833	D 3	3844	C 2
1703	C 1	1714	F 11	2801	B 10	2809	C 5	2833	F 3	2844	L 1	2859	D 6	2875	C 9	3600	F 11	3807	C 4	3818	B 2	3834	D 2	3845	C 2
1704	C 3	1715	H 10	2802	D 7	2810	C 5	2834	F 3	2845	G 5	2860	E 5	2876	C 10	3700	D 10	3808	C 4	3819	B 7	3835	D 1	3846	C 2
1705	F 14	1716	F 12	2700	G 10	2812	H 4	2835	C 3	2848	F 5	2861	F 7	2877	D 9	3701	G 11	3809	E 4	3820	B 7	3836	D 2	3847	C 1
1706	F 14	1801	B 6	2801	C 3	2815	C 4	2836	F 4	2851	D 8	2862	E 5	2878	C 9	3702	G 10	3810	B 2	3821	B 3	3837	D 2	3848	D 4
1707	F 15	1810	B 4	2802	B 3	2816	C 3	2837	E 3	2852	C 8	2863	C 9	2879	B 5	3709	G 10	3811	D 2	3822	F 2	3838	C 2	3849	D 2
1708	F 16	1811	D 8	2803	B 4	2817	C 3	2838	D 3	2853	D 8	2866	D 9	2880	D 12	3801	H 3	3812	E 9	3823	C 5	3839	C 3	3850	D 8

COMP. DISK BOARD / COMPONENT SIDE VIEW / AK601

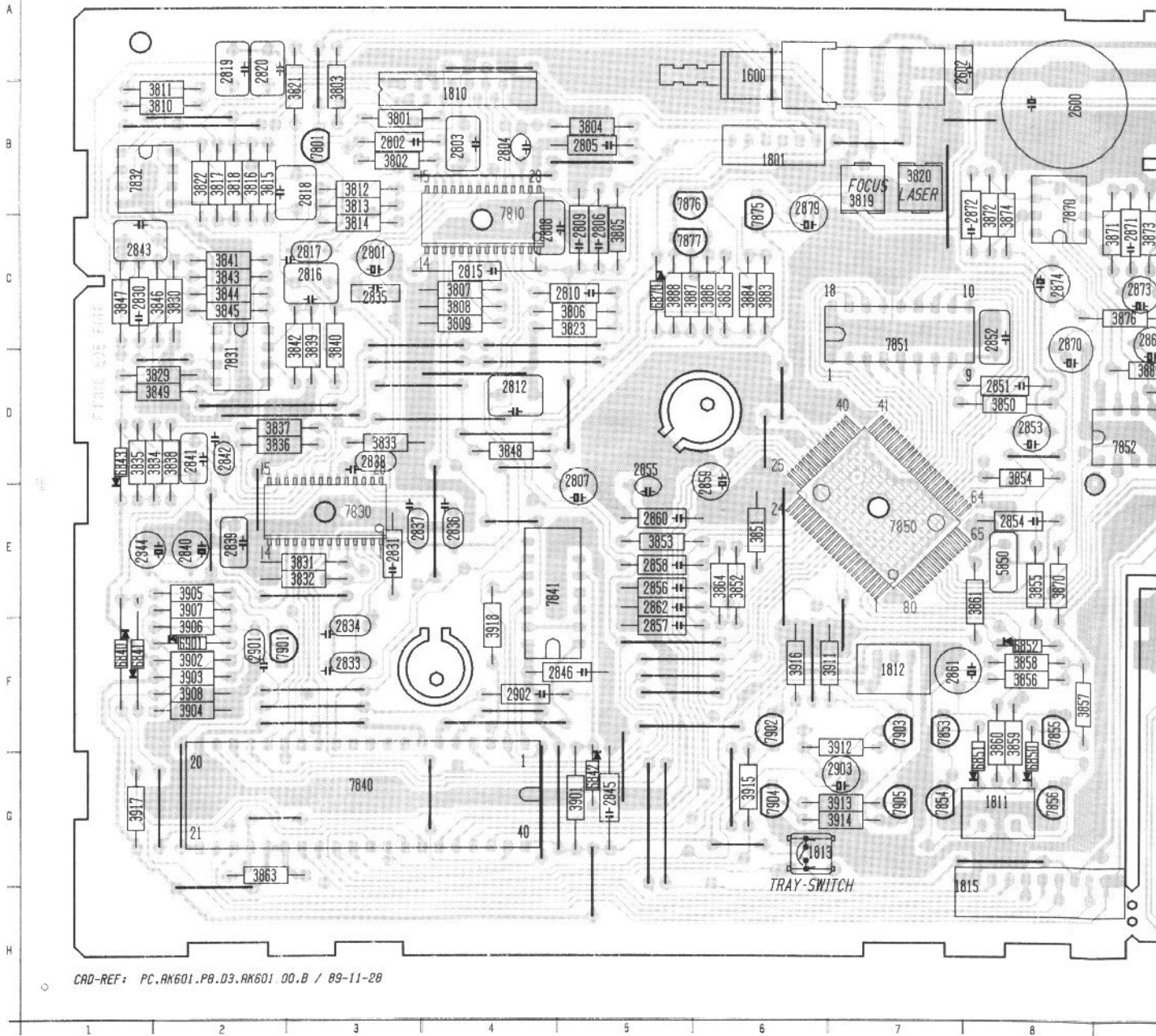

CAD-REF: PC-AK601.P8.D3-AK601.00.B / 89-11-28

Alignment instructions

Measuring point		Adjust with	Value
Laser	Connector 1801 Pin 1 & 2	Trimmpot 3820	50mV ± 2,5mV
Focus-offset	Connector 1801 Pin 3 & 4	Trimmpot 3819	400mV ± 40mV

Use an Millivoltmeter with an high input impedance (≥10MΩ)



CONTINUED PART

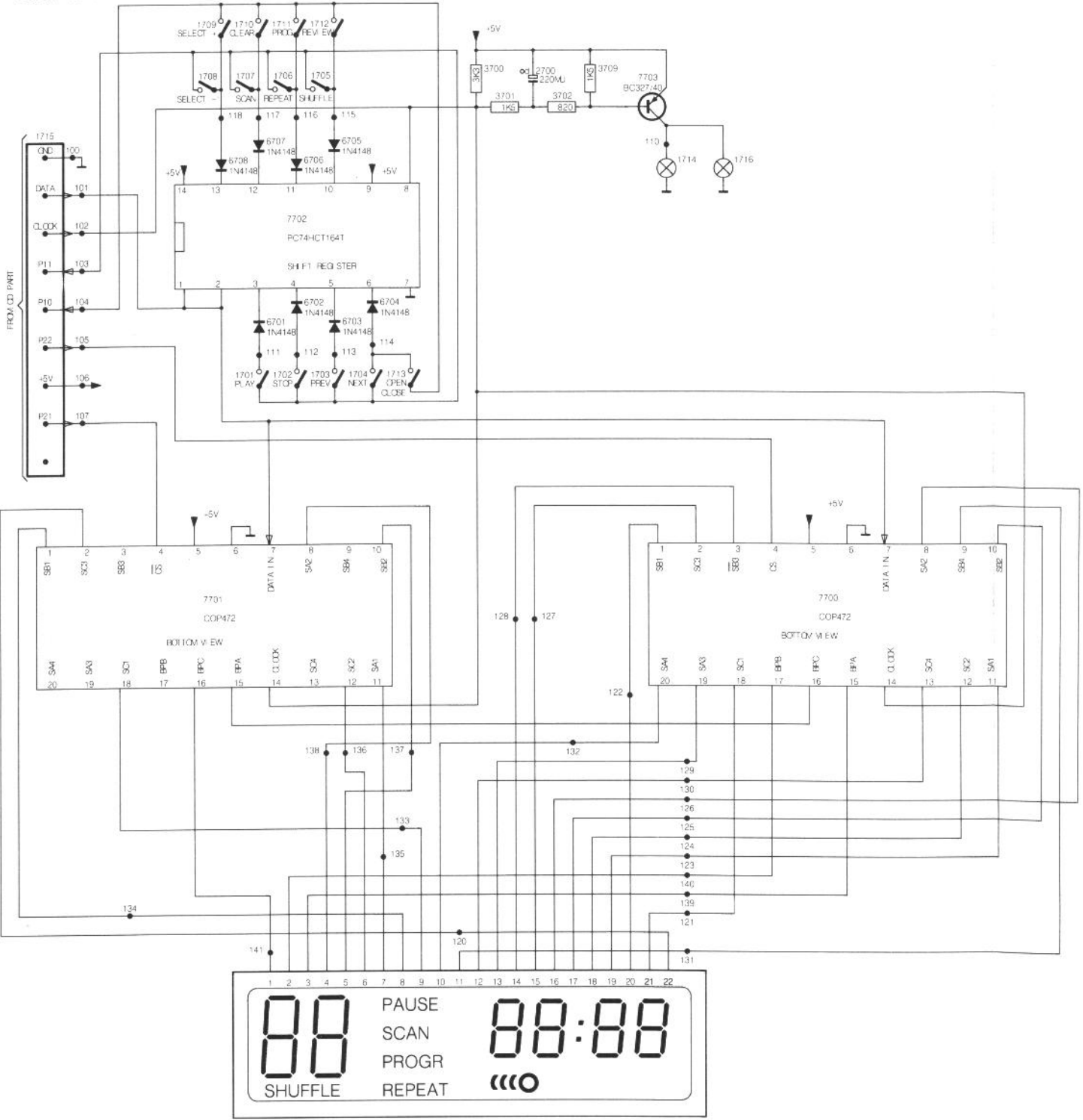

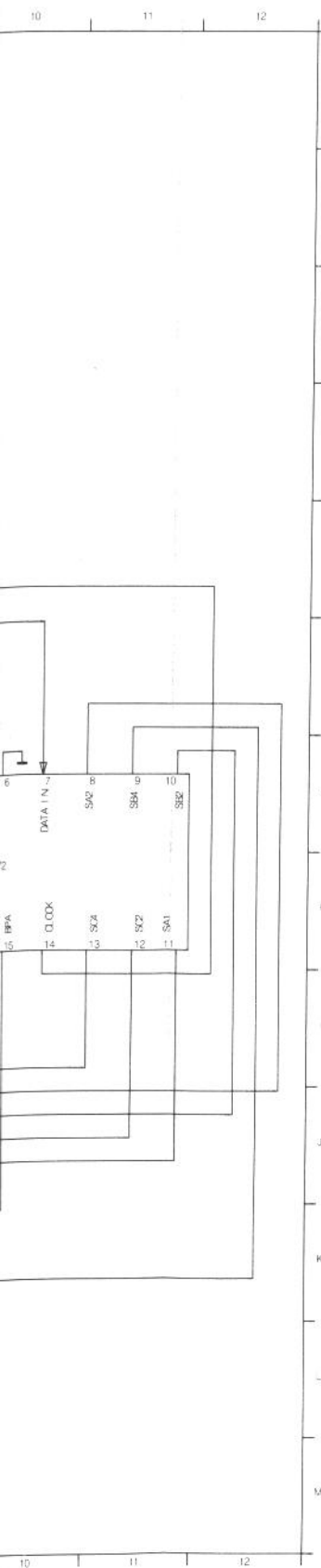

- 1700 M 4
- 1701 E 4
- 1702 E 4
- 1703 E 4
- A 1704 E 5
- 1705 B 4
- 1706 B 4
- 1707 B 3
- 1708 B 3
- 1709 A 3
- 1710 A 4
- 1711 A 4
- B 1712 A 4
- 1713 L 5
- 1714 C 8
- 1715 B 1
- 1716 C 8
- 2700 B 6
- 3700 B 6
- 3701 B 6
- C 3702 B 7
- 3708 B 7
- 6701 D 4
- 6702 D 4
- 6703 D 4
- 6704 D 5
- 6705 C 4
- 6706 C 4
- D 6707 C 4
- 6708 C 3
- 7700 G 9
- 7701 G 3
- 7702 C 4
- 7703 B 8

E

F

G

H

I

J

K

L

M